

NOTE

This manual documents the Model 5100 Series B and its assemblies at the revision levels shown in Appendix 7A. If your instrument contains assemblies with different revision letters, it will be necessary for you to either update or backdate this manual. Refer to the supplemental change/errata sheet for newer assemblies, or to the backdating sheet in Appendix 7A for older assemblies.

5100 Series B Calibrators

Instruction Manual

P/N 522987
August 1979



WARRANTY

Notwithstanding any provision of any agreement the following warranty is exclusive:

The JOHN FLUKE MFG. CO., INC., warrants each instrument it manufactures to be free from defects in material and workmanship under normal use and service for the period of 1-year from date of purchase. This warranty extends only to the original purchaser. This warranty shall not apply to fuses, disposable batteries (rechargeable type batteries are warranted for 90-days), or any product or parts which have been subject to misuse, neglect, accident, or abnormal conditions of operations.

In the event of failure of a product covered by this warranty, John Fluke Mfg. Co., Inc., will repair and calibrate an instrument returned to an authorized Service Facility within 1 year of the original purchase; provided the warrantor's examination discloses to its satisfaction that the product was defective. The warrantor may, at its option, replace the product in lieu of repair. With regard to any instrument returned within 1 year of the original purchase, said repairs or replacement will be made without charge. If the failure has been caused by misuse, neglect, accident, or abnormal conditions of operations, repairs will be billed at a nominal cost. In such case, an estimate will be submitted before work is started, if requested.

THE FOREGOING WARRANTY IS IN LIEU OF ALL OTHER WARRANTIES, EXPRESS OR IMPLIED, INCLUDING BUT NOT LIMITED TO ANY IMPLIED WARRANTY OF MERCHANTABILITY, FITNESS, OR ADEQUACY FOR ANY PARTICULAR PURPOSE OR USE. JOHN FLUKE MFG. CO., INC., SHALL NOT BE LIABLE FOR ANY SPECIAL, INCIDENTAL, OR CONSEQUENTIAL DAMAGES, WHETHER IN CONTRACT, TORT, OR OTHERWISE.

If any failure occurs, the following steps should be taken:

1. Notify the JOHN FLUKE MFG. CO., INC., or nearest Service facility, giving full details of the difficulty, and include the model number, type number, and serial number. On receipt of this information, service data, or shipping instructions will be forwarded to you.
2. On receipt of the shipping instructions, forward the instrument, transportation prepaid. Repairs will be made at the Service Facility and the instrument returned, transportation prepaid.

SHIPPING TO MANUFACTURER FOR REPAIR OR ADJUSTMENT

All shipments of JOHN FLUKE MFG. CO., INC., instruments should be made via United Parcel Service or "Best Way"* prepaid. The instrument should be shipped in the original packing carton; or if it is not available, use any suitable container that is rigid and of adequate size. If a substitute container is used, the instrument should be wrapped in paper and surrounded with at least four inches of excelsior or similar shock-absorbing material.

CLAIM FOR DAMAGE IN SHIPMENT TO ORIGINAL PURCHASER

The instrument should be thoroughly inspected immediately upon original delivery to purchaser. All material in the container should be checked against the enclosed packing list. The manufacturer will not be responsible for shortages against the packing sheet unless notified immediately. If the instrument is damaged in any way, a claim should be filed with the carrier immediately. (To obtain a quotation to repair shipment damage, contact the nearest Fluke Technical Center.) Final claim and negotiations with the carrier must be completed by the customer.

The JOHN FLUKE MFG. CO., INC., will be happy to answer all applications or use questions, which will enhance your use of this instrument. Please address your requests or correspondence to: JOHN FLUKE MFG. CO., INC., P.O. BOX C9090, EVERETT, WASHINGTON 98206, ATTN: Sales Dept. For European Customers: Fluke (Holland) B.V., P.O. Box 5053, 5004 EB, Tilburg, The Netherlands.

*For European customers, Air Freight prepaid.

John Fluke Mfg. Co., Inc., P.O. Box C9090, Everett, Washington 98206

Table of Contents

SECTION	TITLE	PAGE
1	INTRODUCTION AND SPECIFICATION	1-1
1-1.	INTRODUCTION	1-1
1-7.	BASIC CALIBRATION	1-1
1-8.	Series Common Features	1-1
1-14.	Storage System Models	1-2
1-16.	Element Resistant Models	1-2
1-18.	OPTIONS	1-2
1-19.	Analog Options	1-2
1-21.	Interface Options	1-2
1-24.	Boost Mode Accessories	1-2
1-25.	SPECIFICATIONS	1-2
1-26.	Summarized Specifications	1-2
1-28.	Complete Specifications	1-3
2	OPERATING INSTRUCTIONS	2-1
2-1.	INTRODUCTION	2-1
2-3.	SHIPPING INFORMATION	2-1
2-5.	OPTIONS AND ACCESSORIES	2-1
2-7.	INSTALLATION	2-1
2-9.	OPERATING FEATURES	2-2
2-10.	Front Panel Controls	2-2
2-31.	Rear Panel	2-2
2-33.	Error Messages	2-2
2-35.	List (Storage Only)	2-2
2-40.	Program Write-Protect (Storage Only)	2-13
2-42.	LOCAL OPERATION	2-15
2-43.	Initialization	2-15
2-45.	Status During Function Change	2-15
2-47.	Meter Connection Procedure	2-15
2-49.	DC Voltage Output	2-15
2-51.	AC Voltage Output	2-16
2-53.	Wideband Output	2-17
2-55.	Direct Current Output	2-17
2-57.	Alternating Current Output	2-18
2-59.	Resistance Output	2-19
2-61.	dBm Output (AC Volts Only)	2-19
2-63.	Boost Mode Operation	2-20
2-72.	Enter Entry Limit	2-21
2-74.	Tolerance Limit Entry	2-22
2-76.	Error Mode Operation	2-22
2-91.	NEW REF CAL 1 Ω Operation	2-23

(continued on page ii)

TABLE OF CONTENTS, *continued*

SECTION	TITLE	PAGE
2-97.	Fractional-Scale Operation	2-34
2-100.	External Oscillator Operation	2-24
2-104.	Recall Operations	2-25
2-107.	Storage System Operations (Storage Only)	2-25
2-133.	REMOTE OPERATION	2-28
2-137.	Initiation Characters	2-29
2-148.	String Commands	2-30
3	THEORY OF OPERATION	3-1
3-1.	INTRODUCTION	3-1
3-4.	INSTRUMENT BLOCK DIAGRAM	3-1
3-9.	FUNCTIONAL BLOCK DIAGRAM	3-1
3-10.	DC Voltage Less Than 20 Volts	3-1
3-13.	AC Voltage	3-4
3-17.	AC and DC Voltage, 20 Volts and Higher	3-4
3-19.	AC Current Under 200 mA	3-4
3-22.	DC Current Under 200 mA	3-9
3-24.	Direct and Alternating Current >200 mA	3-9
3-26.	Resistance	3-9
3-28.	Control System	3-9
3-38.	DETAILED CIRCUIT ANALYSIS	3-14
3-40.	Power Supply Regulator	3-14
3-55.	Digital-to-Analog Converter (DAC)	3-14
3-68.	Analog Control	3-16
3-82.	Power Amplifier	3-17
3-99.	Extended High Voltage	3-18
3-105.	Oscillator	3-19
3-114.	Ranging Assembly	3-20
3-135.	Controller	3-21
3-145.	Front Panel	3-22
3-151.	Guard Isolator	3-22
3-155.	Tape Interface (Storage Only)	3-22
4	MAINTENANCE	4-1
4-1.	INTRODUCTION	4-1
4-3.	SERVICE INFORMATION	4-1
4-6.	GENERAL MAINTENANCE	4-1
4-7.	Cleaning	4-1
4-9.	Air Filter Maintenance	4-1
4-11.	Line Voltage Selection	4-2
4-13.	Fuse Replacement	4-2
4-15.	Instrument Assembly Disassembly	4-2
4-39.	PERFORMANCE TEST	4-5
4-43.	Calibration Test Equipment Accuracy Considerations	4-5
4-47.	Equipment Preparation	4-6
4-49.	DC Offset Voltage	4-7
4-51.	DC Voltage Tests	4-8
4-53.	DC Ripple and Noise Tests	4-9
4-55.	DC Current Tests	4-10
4-57.	AC Voltage Tests	4-11
4-59.	AC Distortion and Noise Tests	4-13
4-61.	Frequency Accuracy Tests	4-13
4-63.	Resistance Tests	4-14
4-67.	AC Current Tests	4-15
4-70.	Overload Tests	4-16
4-73.	Storage System Test (Storage Only)	4-16
4-76.	CALIBRATION PROCEDURE	4-16
4-77.	Introduction	4-16
4-81.	Power Supply Calibration	4-17

(continued on page iii)

TABLE OF CONTENTS, *continued*

SECTION	TITLE	PAGE
4-83.	Power Amplifier (A17) Calibration	4-17
4-90.	Reference Voltage Calibration	4-19
4-92.	Low Range Ohms Calibration	4-20
4-94.	DC Zero Calibration	4-20
4-98.	High Range Ohms Calibration	4-21
4-101.	Millivolt Range Calibration	4-22
4-103.	AC Calibration	4-22
4-105.	Storage System Calibration (Storage Only)	4-23
4-107.	Factory Selected Component Replacement	4-23
4-117.	TROUBLESHOOTING	4-26
5	LISTS OF REPLACEABLE PARTS	5-1
	TABLE OF CONTENTS	5-1
	5-1. INTRODUCTION	5-2
	5-4. HOW TO OBTAIN PARTS	5-2
6	OPTION AND ACCESSORY INFORMATION	6-1
	TABLE OF CONTENTS	6-1
7	GENERAL INFORMATION	7-1
7A	MANUAL CHANGE INFORMATION	7A-1
8	SCHEMATIC DIAGRAMS	8-1
	TABLE OF CONTENTS	8-1



List of Tables

TABLE	TITLE	PAGE
1-1.	Summarized Specifications	1-3
1-2.	DC Volts Specifications	1-4
1-3.	AC Volts Specifications	1-5
1-4.	Current Specifications	1-6
1-5.	Resistance Specifications	1-8
1-6.	Wideband Option -03 Specifications	1-9
1-7.	General Specifications	1-10
1-8.	System Specifications for Power Amplifier Application (5100 Series B + Y5000, Y5001, 5205A/5215A Combination)	1-11
1-9.	System Specification for Transconductance Amplifier Application (5100 Series B + Y5000, Y5020, 5220A Combination)	1-12
2-1.	Option and Accessories	2-1
2-1.	Front Panel Display and Control	2-4
2-3.	Data Entry Group	2-5
2-4.	Main Output Group	2-7
2-5.	Output Display Group	2-8
2-6.	Central Display Group	2-9
2-7.	Error Mode Group	2-9
2-8.	Storage Group (Storage Only)	2-10
2-9.	Rear Panel	2-13
2-10.	Error Codes	2-13
2-11.	Standby/Operate Status Change	2-15
2-12.	External Frequency/Voltage Limitations	2-24
2-13.	External Oscillator Frequency Ranges	2-25
2-14.	Programming Codes	2-29
2-15.	Interface Interrupt Codes	2-30
2-16.	Interface Output Codes	2-30
2-17.	Status Register Message Assignments	2-32
2-18.	Status Message Function Codes	2-34
2-19.	Status Message Examples	2-34
3-1.	Power Amp Relay Controls	3-17
4-1.	Input Line Voltage Switch Settings	4-2
4-2.	Test Equipment	4-6
4-3.	DC Voltage Tests	4-9
4-4.	DC Ripple and Noise Tests	4-10
4-5.	DC Current Test	4-11
4-6.	AC Voltage Tests	4-12
4-7.	AC Distortion and Noise Tests	4-14
4-8.	Frequency Accuracy Tests	4-14
4-9.	Resistance Tests	4-15
4-10.	PCB Reference Designators	4-17

(continued on page vi)

LIST OF TABLES, *continued*

TABLE	TITLE	PAGE
4-11.	Power Supply Regulator Adjustments	4-17
4-12.	Divider Resistor Selection	4-25
4-13.	High Frequency Capacitor Selection	4-26
4-14.	Display Troubleshooting	4-27
4-15.	Analog Circuitry Troubleshooting	4-30
4-16.	Power Supply Regulator Troubleshooting	4-36
4-17.	Power Amp Troubleshooting	4-43
4-18.	Extended High Voltage Troubleshooting	4-47
4-19.	Controller Troubleshooting	4-49
4-20.	Isolator Troubleshooting	4-52
4-21.	Tape Interface Troubleshooting	4-53

List of Illustrations

FIGURE	TITLE	PAGE
2-1.	Front Panel	2-3
2-2.	Data Entry Group	2-4
2-3.	Main Output Group	2-6
2-4.	Output Display Group	2-8
2-5.	Central Display Group	2-8
2-6.	Error Mode Group	2-9
2-7.	Storage Group (Storage Only)	2-10
2-8.	Rear Panel	2-12
2-9.	LIST Program	2-14
2-10.	LIST Data (Storage Only)	2-14
2-11.	Tape Write-Protect Feature	2-15
2-12.	Meter Connections	2-16
3-1.	5100B Block Diagram	3-2
3-2.	2V dc to 19.9999V dc and 50 Ω Override Inputs	3-3
3-3.	Less than 2V dc Outputs Block Diagram	3-5
3-4.	AC Voltage Block Diagram	3-6
3-5.	AC and DC Voltage, 20V and Higher	3-7
3-6.	AC Current Under 200 mA	3-8
3-7.	DC Current Under 200 mA	3-10
3-8.	1 Ω - 10 k Ω Resistance	3-11
3-9.	100 k Ω - 10 M Ω Resistance	3-12
3-10.	Control System Block Diagram	3-12
3-11.	Controller Block Diagram	3-13
3-12.	Power Amp Relay Controls	3-17
3-13.	Isolator Block Diagram	3-23
3-14.	Write Timing Diagram (Storage Only)	3-24
3-15.	Read Timing Diagram (Storage Only)	3-25
4-1.	Input Line Voltage Switches	4-2
4-2.	Accuracy Uncertainties	4-7
4-3.	Offset Voltage Checks	4-7
4-4.	DC Low Voltage Tests	4-8
4-5.	DC Voltage Tests	4-9
4-6.	DC Current Tests	4-10
4-7.	AC Voltage Tests	4-12
4-8.	AC Low Voltage Tests	4-13
4-9.	Current Source Transfer Connections	4-15
4-10.	Resistance Computation Examples	4-15
4-11.	Calibration Resistance Computation Examples	4-19
4-12.	Differential Connections	4-21

5100 B
Calibrator

5101 B
Calibrator

5102 B
Meter Calibrator

Section 1

Introduction & Specifications

1-1. INTRODUCTION

1-2. The microprocessor controlled 5100 Series B Calibrator outputs are programmable from the Front Panel or through an optional remote interface, through a wide range of DC voltages and current; AC voltages, current and dBm; and resistance. Connections on the Front Panel include terminals for output, sense, voltage guard, and current guard. A chassis binding post is available on the rear panel. Available on the Front Panel is a dedicated BNC output connector for use with the Wideband Option -03 which extends the frequency range of the instrument. The connector is installed in all instruments, allowing addition of the option at some later date, if desired.

1-3. The output can be modified using the Front Panel Error Mode controls or through an optional remote interface. This allows the operator, in all outputs except frequency, to modify the output and read the deviation from the base in percentage or digits on the Front Panel or the remote device. Frequency can be modified to step through the entire range of the meter under test with minimum amount of reprogramming by the operator.

1-4. The 5100 Series has three models of calibrators. The basic model is the 5100B which has all the features listed above. The Model 5101B has all the features of the 5100B plus an integral storage system consisting of a memory and tape cassette which allows the operator to enter or record a program to step the calibrator through a predetermined sequence. The 5102B is electronically identical to the 5100B with the addition of an environmental, element-resistant, fiberglass case plus all-position relays for operation at any angle. This permits safer and easier transport plus the ability to operate in any position.

1-5. Data (paragraphs, tables, or figures) pertaining to only a portion of the series, and not the entire series, is marked by following the title of the applicable item with a descriptive notation enclosed in parentheses. Instruments containing a storage memory and tape system, e.g., 5101B are identified by the notation (Storage Only). Those with the element-resistant case, e.g., 5102B, are identified by the notation (Fiberglass Case Only).

1-6. The 5100 Series B instruments are an extension of the preceding 5100 Series A instruments. They have all the capabilities of the "A" Series plus the following added features: the instrument now has the capability to output up to 1100V ac at 50 Hz through 1 kHz as opposed to the 400 Hz only, in the "A" Series. The boost capability has been activated allowing the "B" Series to slave power and/or current amplifiers to extend its limits. Special handling and equipment are no longer required to calibrate VOM's with a non-linear input impedance.

1-7. BASIC CALIBRATOR

1-8. Series Common Features

1-9. All models of the calibrator can provide dc voltage outputs from 0 to 1100 volts on six ranges with resolutions ranging from 0.1 microvolts to 10 millivolts. Direct current outputs are available from 10 microamps to 2 amps on five ranges with resolution between 1 nanoamp and 10 microamps.

1-10. AC voltage outputs between 1 millivolt and 1100 volts are available from the 50 Hz minimum frequency up to 1 kHz. From that point the maximum voltage available is 110 volts up to 20 kHz, dropping to a 20 volt maximum from 30 kHz to 50 kHz. Six ranges are available for ac voltage outputs with resolution varying from 0.1 microvolt to 10 millivolts. Five alternating current ranges control output from 10 microamps to 2 amps at frequencies of 50 Hz to 1 kHz, with resolution between 1 nanoamp and 10 milliamps.

1-11. All instruments in the series have the capability to extend their voltage (power) and current limits through the BOOST Function using the Y5000 Interface Accessory and selected external amplifiers. Loads up to 200 mA can be handled when a Fluke Model 5202A/5215A is connected through the interface accessory and the applicable cable. Output currents up to $\pm 19.9999A$ are available when a Fluke Model 5220A is connected through the interface and the applicable cable.

1-12. Resistance outputs at the cardinal values from 1 ohm to 10 Megohms are available. The outputs from 1 ohm to 10 kilohm have a four-terminal measurement capability. The 100 kilohm, 1 Megohm, and 10 Megohm outputs use two-terminal measurements with the OUTPUT HI and SENSE HI, and OUTPUT LO and SENSE LO terminals, respectively, connected internally.

1-13. Modification of the output to measure the deviation in a percent of error figure is displayed for each change of the output from the base. The frequency may be altered for AC outputs to cover a range of frequencies; however, there is no percent of error display. The modifications can be programmed from either the Front Panel or a remote source.

1-14. Storage System Models

1-15. The storage system consists of a storage memory and a mini-cassette tape system. The storage memory holds up to 64 separate fixed length instructions. Any field not filled when an instruction is created is filled with the default condition; i.e., either the allowable maximum or minimum, as applicable. Data stored in the memory to form a test program for an instrument, or instruments, may be read out, as desired, or transferred, through the use of the integral tape system, to a tape for permanent record. The storage memory may be loaded from a prerecorded tape through the tape system to perform a standard calibration procedure. A program must be loaded into the storage memory to be run, the instrument is not able to operate directly from the prerecorded tape. A printed listing of the program or the data from the step in progress can be obtained from storage system models equipped with an optional remote interface and external printer.

CAUTION

Tapes used must be certified digital mini-cassettes that conform with ANSI standard X3B5/77-49. Audio quality tapes will not give acceptable results.

1-16. Element Resistant Models

1-17. The environmental, element-resistant case is a fiberglass shell with removable front and rear covers. The case has handles to provide ease of transportation and seals on the case openings to resist entrance of the elements when the case is closed. The covers must be removed to operate the system. The only change in internal circuitry is the substitution of all-position relays so that the instrument can be operated while sitting at any angle. Operation of the instrument is identical with the standard instrument.

1-18. OPTIONS

1-19. Analog Options

1-20. The Wideband Option (-03) allows outputs of 300 μV (-57.5 dBm) to 3.1623V rms (+23 dBm) at frequencies from 10 Hz to 10 MHz into a load impedance of 50 ohms. The output impedance is 50 ohms and 50 ohm coaxial cable should be used to transfer the output signal.

1-21. Interface Options

1-22. Two system interface options are available for the 5100 Series. Option -05 interfaces the instrument to the IEEE 488-1975 Bus System. Option -06 interfaces the instrument to a system using a RS-232-C Interface. Only one of the interface options can be installed at a time; however, they are easily exchanged with a minimum of operator training and time.

1-23. Boost Mode Accessories

1-24. The Boost Mode of Operation permits the operator to slave the Fluke Model 5205A/5215A and/or the Fluke Model 5220A to a 5100 Series Calibrator to extend the power and/or current capabilities of the instrument. Required are the Y5000 Interface and the applicable dedicated cable assembly, Y5001 to the Model 5205A/5215A, or Y5002 to the Model 5220A. Operation of the Models 5205A and 5215A is the same except that DC voltage outputs cannot be obtained from the Model 5215A.

1-25. SPECIFICATIONS

1-26. Summarized Specifications

1-27. Table 1-1 summarizes the 5100 Series accuracy specifications when they are used in a typical meter calibration service. The tolerances in the table are valid provided the ambient temperature is between 20 degrees and 30 degrees Celsius, the relative humidity is less than 85%, and the input line voltage is within 10% of nominal. In addition, they are applicable only when the instrument being calibrated is an analog voltmeter with more than

1000 ohms/volt sensitivities, a TVM or DVM with greater than 1 Megohm input impedance, or analog or digital ammeter with less than 1 volt total voltage drop.

1-28. Complete Specifications

1-29. The complete specifications for the 5100 Series Calibrators are listed in Table 1-2 through 1-9, with each

table covering a specific portion of the specification. Refer to Table 1-2 for detailed listing on DC volts; Table 1-3 for AC volts; Table 1-4 for Current, both direct and alternating; Table 1-5 for Resistance; Table 1-6 for the Wideband Option -03; Table 1-7, for the General Specifications, including environmental information; Table 1-8, for combined use with a Model 5205A/5215A and Table 1-9, with a Model 5220A.

Table 1-1. Summarized Specifications

PROGRAMMED OUTPUT	RANGE	ACCURACY +/- (% OF OUTPUT + % OF RANGE + FLOOR)
DC Voltage	All	.005 + .001 + 5 μ V
AC Voltage	50 Hz – 1 kHz (All ranges) 1 kHz – 10 kHz (Up to 110V) }	.05 + .005 + 50 μ V
	10 kHz – 20 kHz (Up to 110V) 20 kHz – 50 kHz (Up to 19.9999V) }	.08 + .008 + 50 μ V
	All	.025 + .0025 + .01 μ A
Direct Current	All	.025 + .0025 + .01 μ A
Alternating Current	50 Hz – 1 kHz (All ranges)	.07 + .01 + 2 μ A
Resistance	Four terminal 1 ohm 10 ohm 100 ohm, 1 kilohm, 10 kilohm	.02% .01% .005%
	Two terminal 100 kilohm	.005%
	1 Megohm	.01%
	10 Megohm	.05%

Table 1-2. DC Volts Specifications

DC Volts				
RANGE	RESOLUTION	MAXIMUM CURRENT	RIPPLE AND NOISE (10 Hz to 3 kHz) NO LOAD TO MAXIMUM RATED LOAD	ACCURACY (6 months) (20°C to 30°C)
±(200V to 1100V)	10 mV	6 mA/400 pF max	<0.05% of setting rms	± (0.005% of setting + 0.001% of range + 5 μV)
±(20V to 199.999V)	1 mV	10 mA/400 pF max	<0.05% of setting rms (open to 20k Ω) <0.1% of setting rms (20k Ω to max rated load)	
±(2V to 19.9999V)	100 μV	25 mA/1000 pF	<0.02% of setting + 50 μV rms	
±(0.2V to 1.99999V)	10 μV	Limited by 50Ω output resistance	<0.01% of setting + 25 μV rms	
±(20 mV to 199.999 mV)	1 μV		<0.01% of setting + 25 μV rms	
±(0 to 19.9999 mV)	0.1 μV		<0.01% of setting + 25 μV rms	
±(0 to 1.99999V) 50Ω OVERRIDE	100 μV	25 mA/1000 pF	<0.02% of setting + 50 μV rms	

Temperature Coefficient

Above 30°C and Below 20°C add to accuracy limits ±(5 ppm of setting + 1 ppm of range + 1 μV)/°C. 200V to 1100V range add ±(5 ppm of setting + 2 ppm of range)/°C.

Remote Sensing

Four wire remote sensing is available from 2V to 1100V and below 2V in 50Ω DIVIDER OVERRIDE mode. The three lowest ranges are normally internal sensed. Internal sense connections are made automatically inside the box.

Transient Recovery Time

2 seconds to settle within 50 ppm of final value following any change in output voltage or current for all ranges except 20 to 199.999V, 20 kΩ to 2 kΩ load and switching between two highest ranges which requires 4 seconds.

Short Term Stability (10 Minutes)

At any fixed temperature from 0°C to 50°C the short term stability is ±(10 ppm of setting + 2 ppm of range + 5 μV) except above 500V which is ±25 ppm of setting.

Load Regulation

EXTERNAL SENSE: 2V to 1100V ±10 ppm no load to full rated load. Same for 0V to 1.99999V using 50Ω DIVIDER OVERRIDE.

INTERNAL SENSE: Same as external except max. full load is 400Ω.

Overcurrent Protection

On all ranges current is limited to prevent damage due to an overload or short circuit at output terminals. The operator is alerted by a flashing "O.L." on the central display. After approximately 2 seconds the calibrator goes to standby.

Guard

The DC voltage section is guarded and a front panel terminal is provided labeled "V GUARD".

Table 1-3. AC Volts Specifications

AC Volts					
RANGE ¹	RESOLUTION	MAXIMUM CURRENT	FREQUENCY	AMPLITUDE ACCURACY (6 months) (20°C to 30°C)	TOTAL HARMONIC DISTORTION AND NOISE
200V to 1100V	10 mV	6 mA/400 pF max	(1 mV to 1100V) 50 Hz to 1 kHz	50 Hz to 10 kHz ±(0.05% of setting +0.005% of range +50 μV)	Bandwidth of 10 Hz to 200 kHz. Distortion, line interference + noise including random spikes.
20V to 19.999V	1 mV	10 mA/400 pF max			
2V to 19.9999V	100 μV	25 mA/400Ω/ 1000 pF max	(1 mV to 110V) 50 Hz to 20 kHz (Below 20V) 50 Hz to 50 kHz	>10 kHz to 50 kHz ±(0.08% of setting +0.008% of range +50 μV)	(20V and Higher) 50 Hz to 10 kHz: (0.08% of output) rms
0.2V to 1.99999V	10 μV	2kΩ/1000 pF max			
20 mV to 199.999 mV	1 μV	25 mA from 50Ω source resistance	Accuracy: ±3% Resolution: 1 MSD		(Below 20V) 50 Hz to 10 kHz: (0.05% of output +10 μV) rms 10 kHz to 50 kHz: (0.08% of output + 20 μV) rms
1 mV ² to 19.9999 mV	0.1 μV				

(1) Can be set in dBm = 1 mW across 600Ω = .7746V

(2) 10% Lower voltage available using the Edit control

Temperature Coefficient (Above 30°C and Below 20°C)

AMPLITUDE: Accuracy limits increase by ±(20 ppm of setting +2 ppm of range)/°C

FREQUENCY: Accuracy limits increase by ±0.1%/°C

Remote Sensing

Four wire remote sensing is available from 2V to 1100V. The three lowest ranges are internally sensed. Internal sense connections are made automatically inside the box.

Transient Recovery Time

2 Seconds to settle within 100 ppm for amplitude and within 0.3% for frequency following any change in output voltage, current, or frequency. Switching between two highest ranges requires 2.2 seconds.

Short Term Stability (10 Minutes)

At any fixed temperature from 0°C to 50°C the short term stability is ±(0.01% of range +10 μV).

Load Regulation

EXTERNAL SENSE: 0.2V to 1100V ±200 ppm no load to full rated load.

INTERNAL SENSE: Same as external except voltages less than 0.2V have a load regulation expressed as an output impedance of 50Ω.

The above load regulations are met with reactive loads with power factors between 0.9 and 1.0.

Overcurrent Protection

On all ranges current is limited to prevent damage due to an overload or short circuit at output terminals. The operator is alerted by a flashing "O.L." on the central display. After approximately 2 seconds the calibrator goes to standby.

Table 1-3. AC Volts Specifications (cont)

Guard														
The AC voltage function is guarded and a front panel terminal labeled "V GUARD" is provided.														
DISCRETE FREQUENCIES AVAILABLE														
IN Hz	50	60	70	80	90	100	200	300	400	500	600	700	800	900
110V to 1100V	•	•	•	•	•	•	•	•	•	•	•	•	•	•
20V to 110V	•	•	•	•	•	•	•	•	•	•	•	•	•	•
1 mV to 20V	•	•	•	•	•	•	•	•	•	•	•	•	•	•
IN kHz	1	2	3	4	5	6	7	8	9	10	20	30	40	50
110V to 1100V	•													
20V to 110V	•	•	•	•	•	•	•	•	•	•	•			
1 mV to 20V	•	•	•	•	•	•	•	•	•	•	•	•	•	•

Table 1-4. Current Specifications

DC Current				
RANGE	RESOLUTION	COMPLIANCE VOLTAGE	ACCURACY (6 months) (20°C to 30°C)	RIPPLE AND NOISE
±(0.2A to 1.99999A)	10 μA	0 to 2.1V min	±(0.025% of setting +0.0025% of range +0.01 μA) Compliance voltage: >1V add 0.002% setting/volt	(0.05% of output +0.01 μA) rms Measured with a bandwidth of 10 Hz to 10 kHz including random spikes
±(20 mA to 199.999 mA)	1 μA	0 to 10V min		
±(2 mA to 19.9999 mA)	100 nA	0 to 10V min		
±(0.2 mA to 1.99999 mA)	10 nA	0 to 10V min		
±(10 μA ¹ to 199.999 μA)	1 nA	0 to 10V min		
(1) 10% lower current available using the Edit Control.				
Temperature Coefficient (Above 30°C and Below 20°) The accuracy limits increase by ±(10 ppm of setting +2 ppm of range)/°C				
Transient Recovery Time 1 Second to settle to within 0.01% of final value following any change in current or compliance voltage.				
Short Term Stability (10 Minutes) At any fixed temperature from 0°C to 50°C the short term stability is ±(50 ppm of setting + 5 ppm of range + 0.002 μA).				

Table 1-4. Current Specifications (cont)

RANGE	RESOLUTION	COMPLIANCE VOLTAGE	ACCURACY (6 months) (20°C to 30°C)	FREQUENCY	TOTAL HARMONIC DISTORTION AND NOISE
0.2A to 1.99999A	10 μ A	0 to 1.4V rms min.	$\pm(0.07\%$ of setting + $\pm 0.01\%$ of range +0.02 μ A Compliance voltage: >1V rms add 0.005% of setting/volt	50 Hz to 1 kHz	Distortion, line interference + noise including random spikes (0.05% of output +2 μ A) rms
20 mA to 199.999 mA	1 μ A	0 to 7V rms min.		Accuracy: $\pm 3\%$ Resolution: 1 MSD	
2 mA to 19.9999 mA	100 nA	0 to 7V rms min.		Although no accuracy specifications apply above 1 kHz, output is usable to 5 kHz.	
0.2 mA to 1.99999 mA	10 nA	0 to 7V rms min.			
10 μ A ¹ to 199.999 μ A	1 nA	0 to 7V rms min.			

(1) 10% lower current available using the Edit Control.

Temperature Coefficient (Above 30°C and Below 20°C)
 CURRENT: Accuracy limits increase by $\pm(25$ ppm of setting + 10 ppm of range +0.2 nA)/°C.
 FREQUENCY: Accuracy limits increase by $\pm 0.1\%$ /°C.

Transient Recovery Time
 4 Seconds to settle within 0.02% for current and within 0.3% for frequency following any change in output current, voltage, or frequency.

Short Term Stability (10 Minutes)
 At any fixed temperature from 0°C to 50°C the short term stability is $\pm(0.014\%$ of setting + 0.002% of range + 0.4 μ A).

Load Regulation
 ± 50 ppm +20 nA/volt for a change in the output voltage from 1V to maximum rated compliance voltage. Load regulation is met with reactive loads with power factors between 0.9 and 1.0.

Overvoltage Protection
 On all ranges voltage is limited to not more than 2V peak greater than maximum rated compliance voltage due to an open circuit condition. The operator is alerted by a flashing "O.L." on the central display. After approximately 2 seconds the calibrator goes to standby.

Guard
 The AC current section is guarded and a front panel terminal labeled "I GUARD" is provided.

Table 1-5. Resistance Specifications

Resistance						
RANGE	POWER DISSIPATION	MAXIMUM CURRENT	PEAK VOLTAGE	ACCURACY (6 Months) (20°C to 30°C)	TEMPERATURE COEFFICIENT >30°C and <20°C ACCURACY LIMITS INCREASE BY	POWER COEFFICIENT
1Ω	1W	1A	1V	0.02%	10 ppm/°C	0.1 ppm/mW
10Ω		300 mA	3V	0.01%		
100Ω		100 mA	10V	0.005%	5 ppm/°C	0.3 ppm/mW
1 kΩ		30 mA	30V			
10 kΩ		10 mA	100V			
100 kΩ		3 mA	300V	0.01%	0.2 ppm/mW	
1 MΩ	100 mW	0.3 mA				
10 MΩ	10 mW	0.03 mA	0.05%	10 ppm/°C up to 40°C 50 ppm/°C above 40°C	0.02 ppm/mW	

Two or Four Terminal Ohms Below 100 kΩ

The maximum residual resistance that can be compensated for using the Cal 1Ω function is 0.99999Ω.

Table 1-6. Wideband Option -03 Specifications

Wideband Option -03			
RANGE VOLTS	RANGE APPROX dBm ¹	AMPLITUDE ACCURACY AT 1 kHz TERMINATED IN 50Ω (6 Months 20°C to 30°C)	FREQUENCY VS. AMPLITUDE FLATNESS TERMINATED WITH 50Ω AND 1 FT OF RG58/AU
1V to 3.1623V	+13 to +23	±(0.25% of setting + 0.25% of range)	10 Hz to 30 Hz: ±0.3%
0.31624V to 0.99999V	+3 to +13	±(0.50% of setting + 0.25% of range)	>30 Hz to 1 MHz: ±0.25%
0.1V to 0.31623V	-7 to +3	±(0.75% of setting + 0.25% of range)	>1 MHz to 5 MHz
31.624 mV to 99.999 mV	-17 to -7	±(1.00% of setting + 0.25% of range)	±0.25% above 1 mV ±0.6% at 1 mV and lower
10 mV to 31.623 mV	-27 to -17	±(1.25% of setting + 0.25% of range)	
3.1624 mV to 9.9999 mV	-37 to -27	±(1.50% of setting + 0.25% of range)	>5 MHz to 10 MHz: ±0.6%
1 mV to 3.1623 mV	-47 to -37	±(1.75% of setting + 0.25% of range)	Frequency Resolution: 1 MSD
300 μV to 0.99999 mV	-57 to -47	±(2.00% of setting + 0.25% of range)	Frequency Accuracy: ±3%

(1) 0 dBm = mW across 50Ω = 0.22361V.

Temperature Coefficient (Above 30° and Below 20°C)

AMPLITUDE: Accuracy limits increase by 0.1 times the accuracies listed in the amplitude accuracy column/°C.

FREQUENCY: Accuracy limits increase by 0.25%/°C.

Transient Recovery Time

2 Seconds to settle within 500 ppm for amplitude and within 0.3% for frequency following any change in voltage, current, or frequency.

Harmonics

-40 dB or lower relative to fundamental for each frequency except -32 dB above 5 MHz.

Spurious Outputs

-50 dB or lower relative to fundamental for each frequency.

Overload Protection

A short circuit on the wideband output will not damage the calibrator. Normal operation is restored upon removal.

5100 SERIES WIDEBAND FREQUENCY RESPONSE

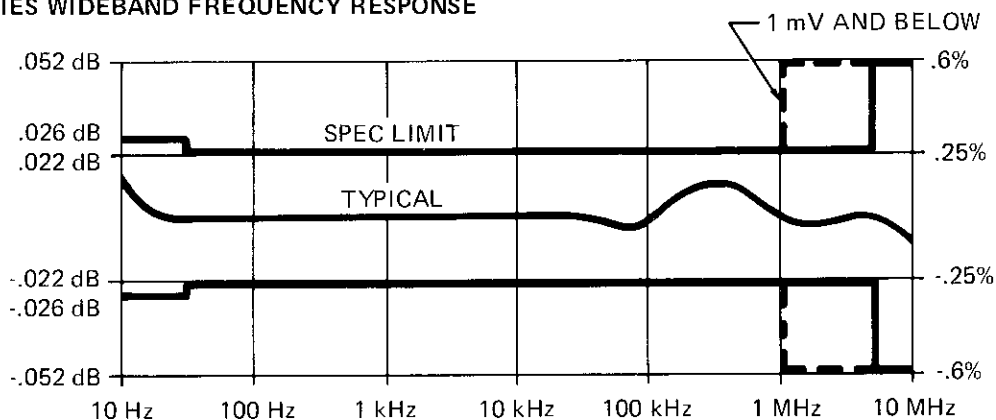

Table 1-7. General Specifications

Stability/Environmental

All specifications have been stated with the following conditions:

Time: Six months

Temp: 25°C ±5°C

R.H.: < 85%

Temperature Range

5100B/5101B: Operating 0°C to +50°C
Non Operating -20°C to +65°C

5101A w/tape: Operating +10°C to +40°C
Non Operating +4°C to +50°C

Humidity Range

0°C to 35°C: 85% RH (Non-Condensing)

35°C to 40°C: 70% RH

40°C to 50°C: 50% RH

Shock and Vibration

Meets requirements of MIL-T-28800 for class 5 style E equipment.

Operating Power

(100V to 240V ±10%: 50 - 60 Hz)

5100B: 200 VA Fully Loaded

5101B: 220 VA Fully Loaded

Warmup

30 Minutes to rated accuracy

Dimensions

22.23 cm H X 43.18 cm L X 60.33 Cm W

(8.75 in H X 17.00 in L X 23.75 in W)

Weight

5100B: 30.4 kgm (67 lbs.) basic.
32.7 kgm (72 lbs.) fully loaded.

5101B: 32.7 kgm (72 lbs.) basic.
34.9 kgm (77 lbs.) fully loaded.

5102B: 35.8 kgm (79 lbs.) basic.
38.1 kgm (84 lbs.) fully loaded.

Table 1-8. System Specifications for Power Amplifier Application
(5100 Series B + Y500, Y5001, 5205A/5215A Combination)

DC Operation (with 5205A)

Output Voltage
±(100 to 1100) volts

Output Current
100 mA maximum

Accuracy
(90-Day) ±(0.06% of output + 20 mV)
(180-Day) ±(0.07% of output + 20 mV)

Maximum Capacitive Load: < 1500 pF

Temperature Coefficient
±(25 ppm of output + 3 mV/°C)

Ripple and Noise
Random noise, in a 1 MHz bandwidth shall not exceed 100 mV rms. Line-related noise shall be less than 50 mV rms.

AC Operation (with 5206A or 5215A)

Output Voltage
100 to 110V rms

Output Current
200 mA from 100 Hz to 50 kHz linearly decreasing to 140 mA in the region 100 Hz to 50 Hz.

Amplitude Accuracy (180-Day, 23°C ±5°C)
50 Hz to 10 kHz ±(.08% E_o + .1 volt)
10 kHz to 50 kHz ±(.12% E_o + .15 volt)

Total Distortion and Noise, (in the band 10 Hz to 1 MHz)
50 Hz to 20 kHz 0.1% of output
20 kHz to 50 kHz 0.2% of output

Maximum Capacitive Load
1500 pF or that value which draws the maximum rated load current, whichever is less.

Amplitude Temperature Coefficient
Above 30°C and below 20°C the accuracy limit increases by ±(30 ppm of output + 3 mV)/°C for 50 Hz to 10 kHz; and ±(50 ppm of output + 5 mV)/°C for 10 kHz to 50 kHz.

**Table 1-9. System Specifications for Transconductance Amplifier Application
(5100 Series B + Y5000, Y5002, 5220A Combination)**

DC Mode

Output Range

± 1 to ± 19.9999 A

Accuracy of Output

$\pm(0.025\%$ of selected output + 1 mA)

Resolution

± 0.1 mA

Temperature Coefficient

$\pm(0.003\%$ of selected output + 100 μ A) in ten minutes, with constant line, load, and temperature.

Line Regulation

Output changes less than 0.001% for a $\pm 10\%$ in line voltage.

Load Regulation

Output changes less than $\pm(0.005\% + 100 \mu\text{A})$ for a full load change of 4 volts of compliance.

AC Mode

Output Range

1A rms to 19.9999A rms

Accuracy of Output

$\pm(0.07\%$ of selected output + 1 mA rms) from 50 Hz to 1 kHz, and $\pm(0.07\%$ of selected output + 1 mA rms) $\times f$ from 1 kHz to 5 kHz, where f = frequency in kHz.

Resolution

± 0.1 mA rms

Temperature Coefficient

$\pm(0.003\%$ of selected output + 100 μ A rms) per degree C, above 30°C and below 20°C.

Short Term Stability

Output changes less than $\pm(0.02\% + 500 \mu\text{A rms})$ in 10 minutes, with constant line, load, and temperature.



static awareness



A Message From
John Fluke Mfg. Co., Inc.

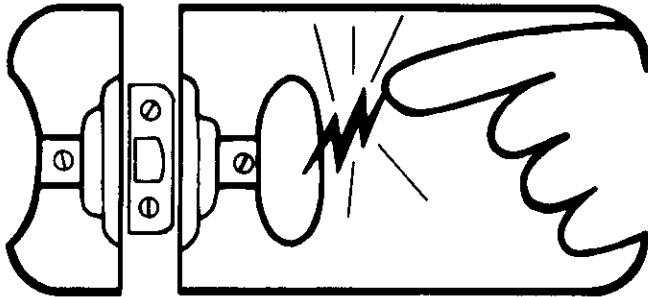

Some semiconductors and custom IC's can be damaged by electrostatic discharge during handling. This notice explains how you can minimize the chances of destroying such devices by:

1. Knowing that there is a problem.
2. Learning the guidelines for handling them.
3. Using the procedures, and packaging and bench techniques that are recommended.

The Static Sensitive (S.S.) devices are identified in the Fluke technical manual parts list with the symbol



The following practices should be followed to minimize damage to S.S. devices.

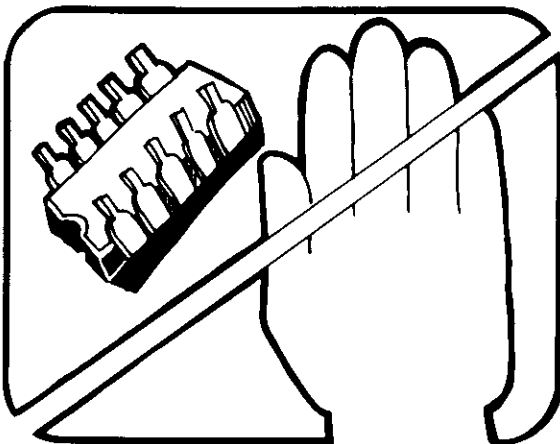

1. MINIMIZE HANDLING

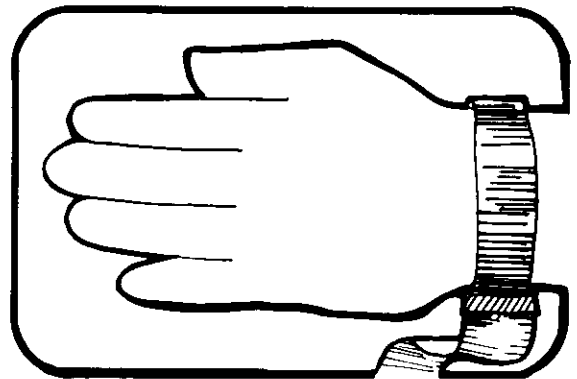

3. DISCHARGE PERSONAL STATIC BEFORE HANDLING DEVICES. USE A HIGH RESISTANCE GROUNDING WRIST STRAP.

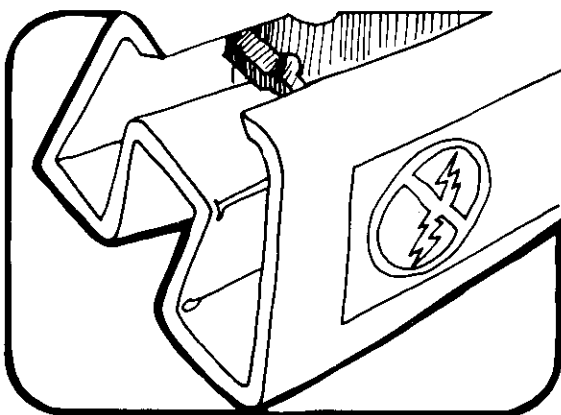

2. KEEP PARTS IN ORIGINAL CONTAINERS UNTIL READY FOR USE.

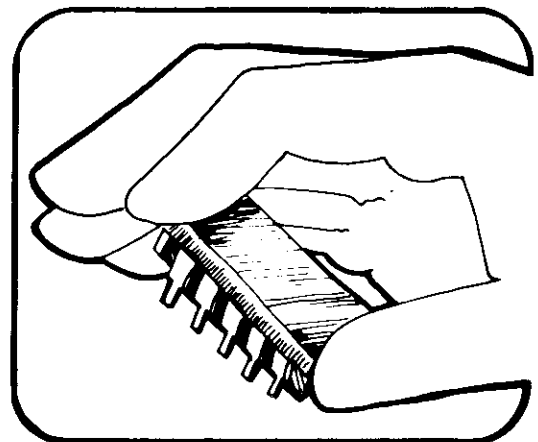

4. HANDLE S.S. DEVICES BY THE BODY

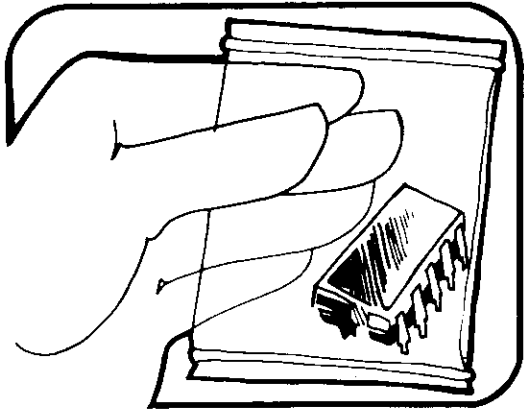

5. USE STATIC SHIELDING CONTAINERS FOR HANDLING AND TRANSPORT

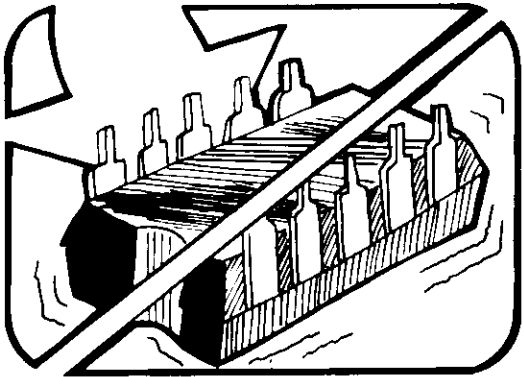

6. DO NOT SLIDE S.S. DEVICES OVER ANY SURFACE

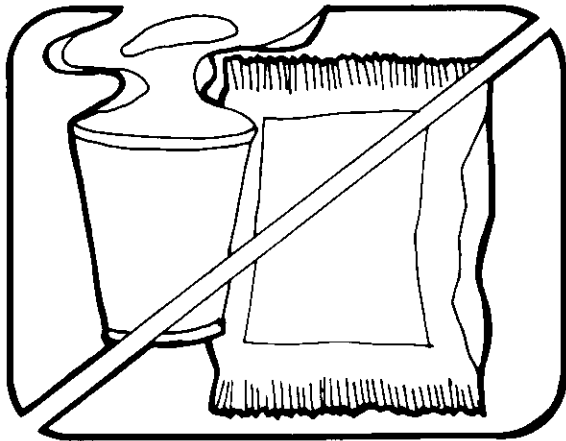

7. AVOID PLASTIC, VINYL AND STYROFOAM® IN WORK AREA

PORTIONS REPRINTED
WITH PERMISSION FROM TEKTRONIX, INC.
AND GENERAL DYNAMICS, POMONA DIV.

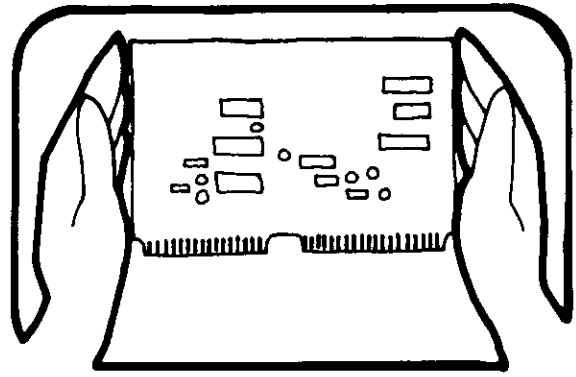

8. WHEN REMOVING PLUG-IN ASSEMBLIES, HANDLE ONLY BY NON-CONDUCTIVE EDGES AND NEVER TOUCH OPEN EDGE CONNECTOR EXCEPT AT STATIC-FREE WORK STATION. PLACING SHORTING STRIPS ON EDGE CONNECTOR HELPS TO PROTECT INSTALLED SS DEVICES.

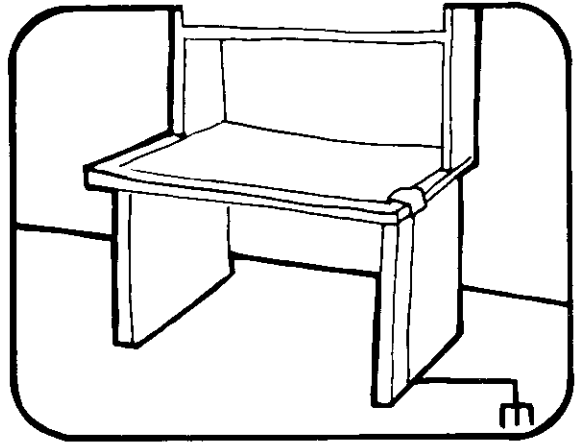

9. HANDLE S.S. DEVICES ONLY AT A STATIC-FREE WORK STATION
10. ONLY ANTI-STATIC TYPE SOLDER-SUCKERS SHOULD BE USED.
11. ONLY GROUNDED TIP SOLDERING IRONS SHOULD BE USED.

A complete line of static shielding bags and accessories is available from Fluke Parts Department, Telephone 800-526-4731 or write to:

JOHN FLUKE MFG. CO., INC.
PARTS DEPT. M/S 86
9028 EVERGREEN WAY
EVERETT, WA 98204

Section 2

Operating Instructions

2-1. INTRODUCTION

2-2. This section contains information regarding installation and operation of the Model 5100 Series Calibrators. It is recommended that the contents of this section be read and understood before any attempt is made to operate the instrument. Should any difficulties arise during operation, contact your nearest John Fluke Sales Representative, or the John Fluke Mfg. Co., P.O. Box 43210, Mountlake Terrace, WA 98043; telephone (206) 774-2211. A list of sales representatives is located in Section 7 of the instruction manual.

2-3. SHIPPING INFORMATION

2-4. The instrument is packed and shipped in a foam-packed cardboard carton. If reshipment is required use the original container or request a new container from the John Fluke Mfg. Co., Inc. Please include the instrument model number with your request.

2-5. OPTIONS AND ACCESSORIES

2-6. Listed in Table 2-1 are the options and accessories available for the 5100 Series B Calibrators. A detailed description of each is included in Section 6 of the instruction manual.

2-7. INSTALLATION

2-8. The 5100 instruments are designed for bench-top use (all) or for installation in a standard 19-inch equipment rack (5100B and 5101B) using the optional accessory rack mounting kit. If desired, accessory chassis slides may be installed to facilitate access to the rack-installed equipment. Information on the installation of rack mounting accessories is given in Section 6 of the instruction manual.

Table 2-1. Options and Accessories

OPTION OR MODEL NO.	TITLE
Option -03	Wideband (10Hz to 10 MHz)
Option -05	IEEE 488-1975 Standard Interface
Option -06	Bit Serial Asynchronous Interface (RS-232-C)
5100A-7003K	Transit Case
5100A-7005K	Extender Accessory Kit
MIS-7190K	Static Controller
M08-205-600	Rack Mounting Kit
M00-280-610	Chassis Slides
Y5000	5100 Series Interface
Y5001	Cable Assembly (Y5000 to Model 5205A/5215A)
Y5002	Cable Assembly (Y5000 to Model 5220A)
Y8001	1 Meter IEEE Cable
Y8002	2 Meter IEEE Cable
Y8003	4 Meter IEEE Cable
Y8005*	IEEE Printer
Y8006*	RS-232-C Printer
Y8007	8-Pack of Minicassettes for Storage System Instruments

** The printing function requires installation of the applicable interface and cable (IEEE or RS-232) in addition to the printer applicable for the type of interface in use, and is applicable to storage models only.*

2-9. OPERATING FEATURES

2-10. Front Panel Controls

2-11. The 5100 Series Front Panels are divided into nine major groupings. The groupings and their general use are shown and explained in Figure 2-1 and Table 2-2. The individual groupings are explained and illustrated in greater detail in later paragraphs of this section.

2-12. The first eight groupings are identical in operation and positioning for all models in the series. The ninth grouping, the Storage System, is present only in the Model 5101B and any material dealing with it is peculiar to the 5101B only.

2-13. POWER

2-14. The Power Group consists of the POWER switch. The switch is in to apply line power to the instrument and out to remove power.

2-15. DATA ENTRY

2-16. Individual items or groupings on the Data Entry keyboard are explained in Figure 2-2 and Table 2-3. In addition, a voltage (V), dBm entry, WIDEBAND, or EXT OSC selection will lock the keyboard from further entries until either the ENTER, RECALL, or CLEAR switch is depressed. If either "Err3" or "Err4" results when ENTER is depressed, the original entry is not changed and the KEYBOARD indicator remains illuminated.

2-17. CONTROL

2-18. Two switches in the Control Group select the Operating mode (OPR/STDBY) and Controlling device (LOCAL/REM). Both switches are push-push type switches that illuminate the applicable indicator to show the selected mode. To change from STDBY to OPR, depress the switch and the OPR indicator will illuminate and the STDBY indicator extinguish. To return to STDBY depress the switch again and the condition will reverse, i.e., the OPR indicator extinguish and the STDBY indicator illuminate. The LOCAL/REM pushbutton switch operates in the same manner.

2-19. WIDEBAND OUTPUT

2-20. When the Wideband -03 Option is installed and selected, the output is present at the BNC type connector with an output impedance of 50 ohms. The maximum output is 3.1623 volts rms (+23 dBm) into 50 ohms.

2-21. MAIN OUTPUT

2-22. An explanation of the terminals, controls, and indicators are given in Figure 2-3 and Table 2-4.

2-23. OUTPUT DISPLAY

2-24. An explanation of the Output Display and indicators is given in Figure 2-4 and Table 2-5.

2-25. CENTRAL DISPLAY

2-26. An explanation of the Central Display and indicators is given in Figure 2-5 and Table 2-6.

2-27. ERROR MODE

2-28. An explanation of the Error Mode Controls and indicator are given in Figure 2-6 and Table 2-7. The use of any control automatically places the instrument in the Error Mode if it has not been selected previously.

2-29. STORAGE SYSTEM (Storage Only)

2-30. An explanation of the Storage System controls and indicators is given in Figure 2-7 and Table 2-8.

2-31. Rear Panel

2-32. The 5100 Series Rear Panel is shown and explained in Figure 2-8 and Table 2-9, respectively.

2-33. Error Messages

2-34. The Central Display and the optional interface output device will indicate an error by displaying an error code. The codes and errors causing them are shown in Table 2-10.

2-35. List (Storage Only)

2-36. The LIST switch in the Storage Group allows the operator to print a hard copy of a stored program or a test in progress, provided the instrument is equipped with one of the optional remote interfaces. The instrument must be in the Store Mode, the first desired step of the program selected, and LIST selected to output a listing of the stored program. The printed output starts with the selected program step and continues to the end of the stored program. The printed output includes the step number; the 5100 output (programmed nominal and full-scale as modified by the Error Mode and/or Fractional-Scale Operations); tolerance and entry limits; and the status, to include Standby/Operate, Sensing, External Oscillator, Wideband, 50 ohm divider override, Boost, and the position of the Error Mode Digit. The placement of the data in the print format is shown in Figure 2-9. Entering any command during a list operation terminates the listing. During a program list the instrument automatically goes to standby.

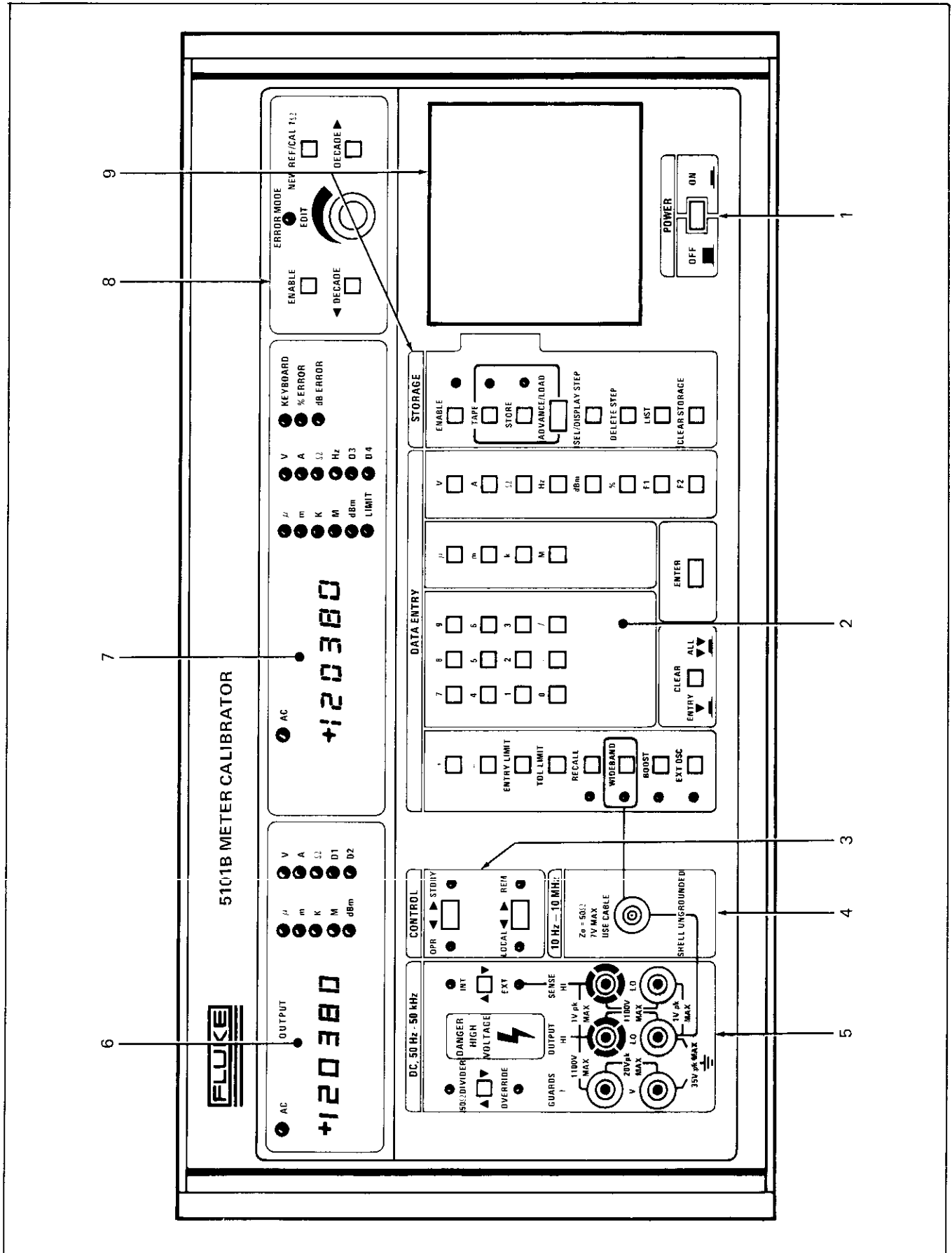

Figure 2-1. Front Panel

Table 2-2. Front Panel Display and Controls

1. POWER	Controls the application and removal of input power.
2. DATA ENTRY	This portion of the Keyboard allows the operator to enter the data desired into the input registers for display, and upon completion places the data into memory.
3. CONTROL	Selects the operational status and mode.
4. WIDEBAND OUTPUT	(10 Hz - 10 MHz) Output terminal for the wideband frequency option. Operational only with Option -03 installed.
5. MAIN OUTPUT	(DC, 50 Hz - 50 kHz) Sense controls and output terminals for the main output.
6. OUTPUT DISPLAY	Displays the output value and function.
7. CENTRAL DISPLAY	Displays the data entered from the data entry section, the error in a percentage figure, the error in dB's, the output frequency when an AC output is selected and the limits, when recalled.
8. ERROR MODE	When enabled, the output may be modified at any decade and the percent of error or dB error deviation from the original figure displayed in percentage or dB respectively.
9. STORAGE SYSTEM (STORAGE ONLY)	When enabled, operates the instrument from a stored program. The program may be entered manually or from a previously recorded tape, read by the integral tape system.

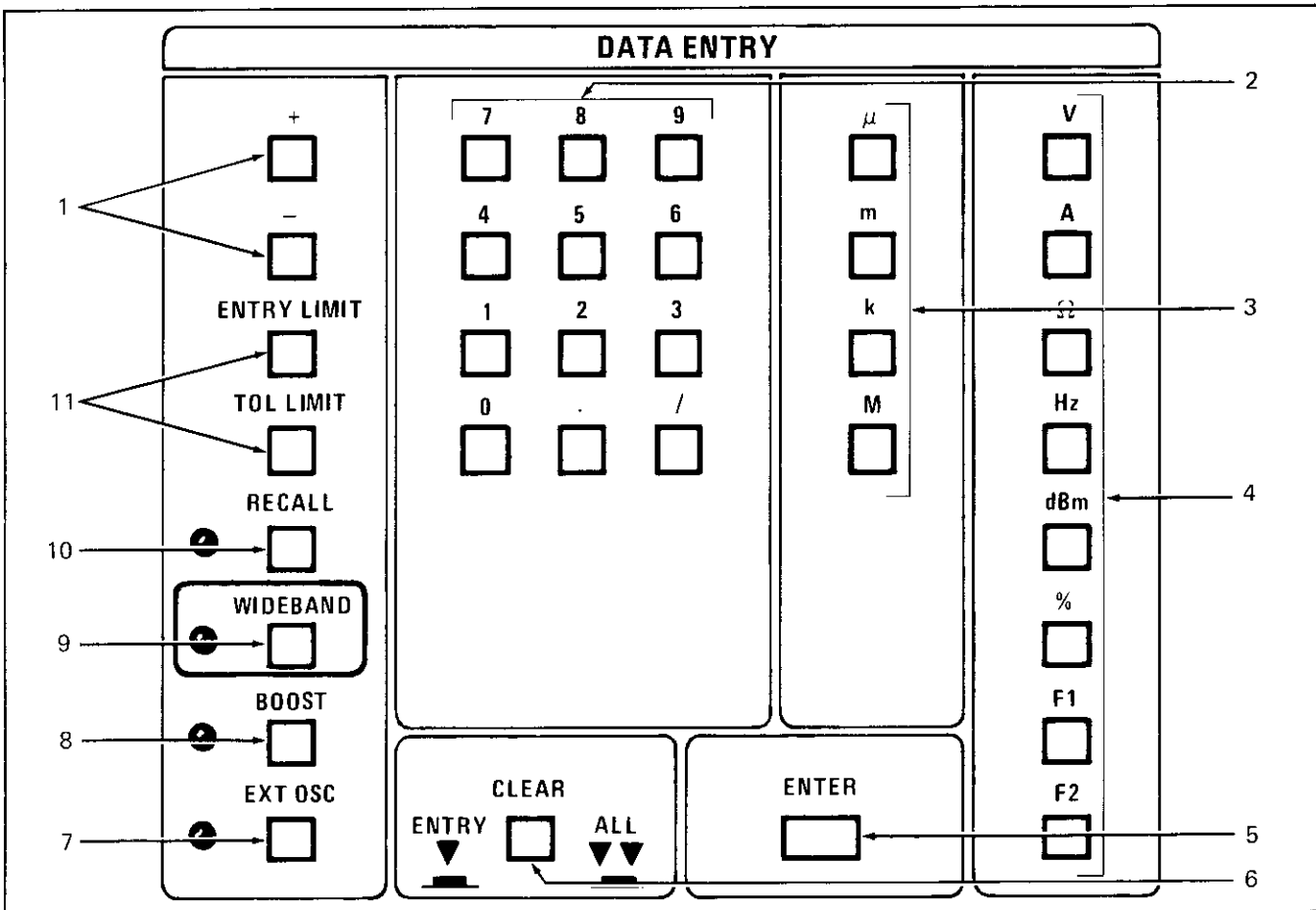

Figure 2-2. Data Entry Group

Table 2-3. Data Entry Group

1.	POLARITY	Depress the applicable keyswitch (+ or -) for the desired polarity with any DC Volts or Amps entry. If an entry is not made positive polarity is assumed, if the DC mode is selected.
2.	NUMERICAL	Depress the applicable keyswitch to enter the numerical data desired. Characters available are 0 through 9, the decimal point (.), and the slash (/) used for ratio. Data is entered by depressing the keys in sequence, beginning with the most significant digit. Restrictions are placed on the numerical entries for frequency and resistance. Only the first digit (the MSD) is variable with a frequency entry. Resistance is variable only in decades from 1 ohm through 10 megohms.
3.	MULTIPLIER	Select the multiplier for the numerical data entered. Available are u(10^{-6}), m(10^{-3}), k(10^3) and M(10^6). No entry assumes a value of units (10^0).
4.	FUNCTION	Designates the function of the numerical data entered. Depress "V" to select Volts, "A" for Amps, "Ω" for Ohms, "Hz" for Frequency, "dBm" for decibels milliwatt and "%" for percentage. Once Volts, Amps, Ohms, Hertz, or dBm have been selected, the instrument is locked into the Keyboard Mode until the data is entered into the instrument with the "ENTER" switch. Switches "F1" and "F2" are not used at this time.
5.	ENTER	When the correct entry has been completed (both magnitude and frequency, if applicable) and is shown on the Central Display (frequency only is displayed for AC entries) or Indicators, as applicable, the ENTER switch is depressed to enter the data into memory and perform the selected action. If an Error display results, the data entered in the keyboard memory is retained until correctly entered or cleared.
WARNING		
IF A KEYBOARD ENTRY IS TERMINATED WITH EITHER A CLEAR OR ERROR MESSAGE THE INSTRUMENT RETAINS ITS PREVIOUS STATUS. IF TWO NEW PARAMETERS ARE ENTERED, E.G., FREQUENCY AND MAGNITUDE, AND ONE IS ILLEGAL THE INSTRUMENT REJECTS THE ILLEGAL ENTRY, WHILE ACCEPTING THE LEGAL ENTRY, SOMETIMES RESULTING IN AN UNPLANNED OUTPUT. FOR SAFETY, ALWAYS VERIFY THE OUTPUT MAGNITUDE OF THE INSTRUMENT, AS SHOWN ON THE OUTPUT DISPLAY, AFTER AN ILLEGAL ENTRY.		
6.	CLEAR	Depress the CLEAR switch once to clear the display (CLEAR ENTRY). A second consecutive depression clears memory and resets the instrument (CLEAR-ALL).
7.	EXTERNAL OSCILLATOR	An external input can be used to obtain a desired frequency not available internally. The Source input must be 1.2V +/-5% and the impedance must be less the 50 ohms. In addition the output frequency must be within the allowable range for the output voltage selected. Only the frequency range is shown on the Central Display, the frequency magnitude is blanked. The function is not active until the ENTER switch is depressed.
8.	BOOST	Selects the Boost Function which extends the Voltage (Power) and Current Capabilities of the instrument. This is accomplished by routing the 5100 B output through an accessory interface to a Fluke Model 5205A/ 5215A Power Amplifier and/or a Fluke Model 5220A Transconductance Amplifier. The Output is available at the terminals of the applicable Amplifier instrument, rather than the Calibrator terminals, once the Boost Function is selected the output value data keyed in, and the ENTER Switch depressed.
9.	WIDEBAND	Selects the Wideband -03 Option with its greater frequency range (10 Hz to 10 MHz) and its dedicated output connector. The function is not active until the ENTER switch is depressed.

Table 2-3. Data Entry Group (cont)

10. RECALL	The RECALL switch can be used to restore to the Central Display the stored limit values (output magnitude), voltage (e.g., when the output display reads in dBm), and frequency. The RECALL switch will also clear the keyboard memory and the keyboard indicator.
11. LIMITS	Depression of the applicable limit switch enables entry into memory of a limit value, including polarity if applicable for that function. If the polarity is not specified, but is applicable, the entered value is applied as both positive and negative limits. When the polarity is entered the unnamed polarity is unchanged. When programmed data exceeds the ENTRY LIMIT previously entered the entry is refused and the message "Err3" is displayed on the Central Display and the LIMIT indicator illuminated. If the error shown on the Central Display during Error Mode Operations exceeds the figure set with TOL LIMIT the LIMIT indicator illuminates and the Central Display numerics flash. This is for information only, it does not effect the operation of the instrument. The tolerance limit is normally set as a percentage of dB limit. If it is set using any other function, i.e. volts, amps, etc. the value is automatically changed to a percentage of the current output value by the instrument controller.

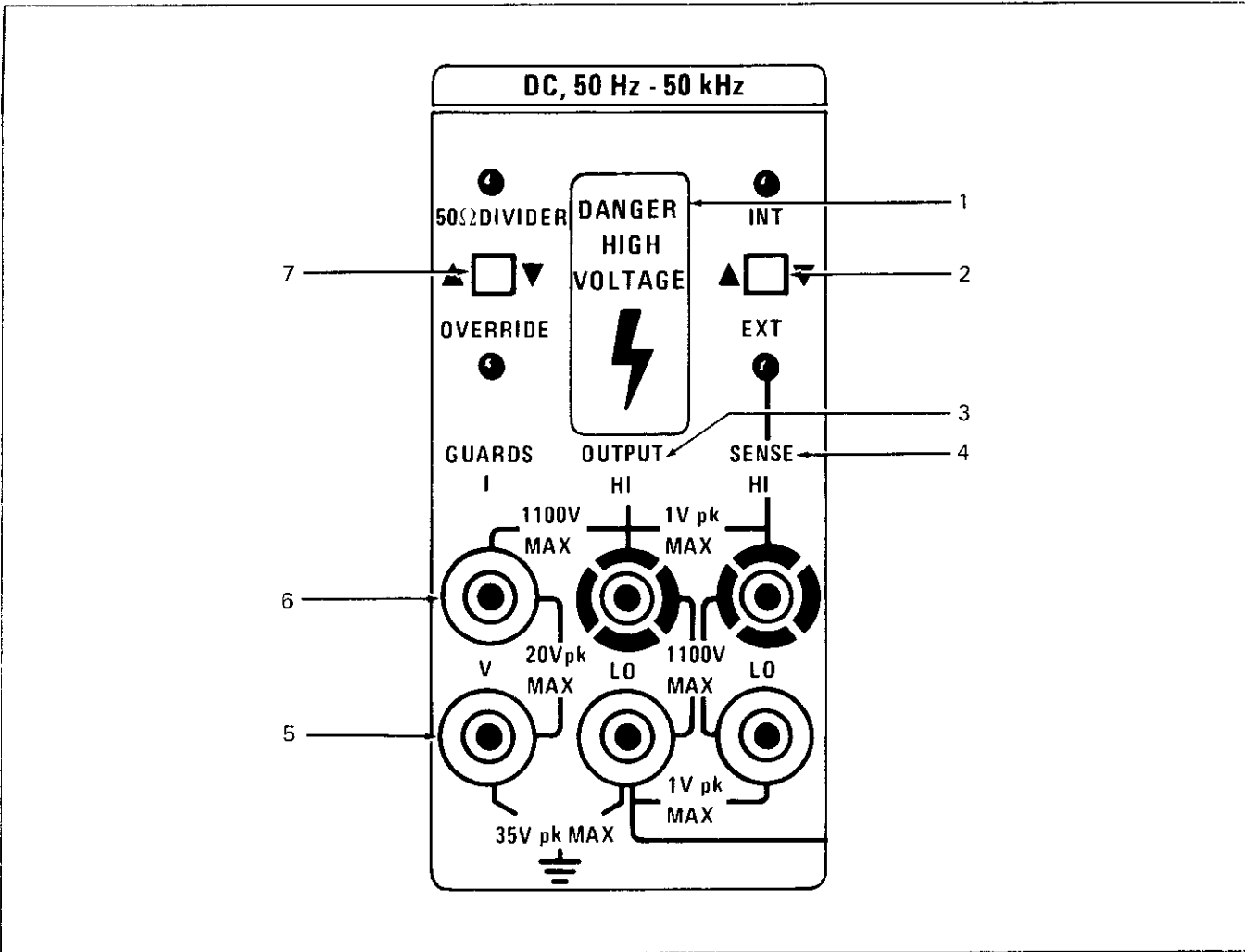

Figure 2-3. Main Output Group

Table 2-4. Main Output Group

- | | | |
|----|------------------|--|
| 1. | WARNING DECAL | Warning that lethal voltages may be present at the output terminals. |
| 2. | SENSE SWITCH | Push-Push toggle switch to select internal (2-wire) or external (4-wire) sensing. The indicator illuminated signifies the type of sensing selected. To change types depress the switch one time and the indicators will reverse. |
| 3. | OUTPUT TERMINALS | The HI and LO output terminals. All standard Voltage, Current, and Resistance outputs are available on these terminals. The maximum difference between the HI and LO terminals is 1100 Volts rms. |

CAUTION

Do not connect the Output HI terminal to chassis, or an earth ground, at any time. Damage to the instrument may result. Never connect either guard terminal to the Output HI terminal. This will cause component failure within the instrument at output voltages above 15 volts.

- | | | |
|----|-----------------|---|
| 4. | SENSE TERMINALS | Used for 4-wire resistance and remote voltage sensing. The allowable difference between Output HI and Sense HI or Output LO and Sense LO is 0.3 Volts. |
| 5. | V GUARD | Connects to the inner shield surrounding the analog sections of the 5100B to isolate them from the chassis, I/O connections and digital section. Normally connected to Output Lo at either the Front Panel or the Voltmeter under test. |
| 6. | I GUARD | Provides a driven shield "guard" around output HI in the AC and DC Current modes. Held at the same voltage as Output HI by a unity gain amplifier, is used to minimize the degradation of accuracy caused by stray capacitance between Output HI and Output LO. |

CAUTION

Output Current inaccuracies will result if the I-Guard terminal is connected to the V-Guard, Output LO, Chassis, or Sense terminal.

- | | | |
|----|--------------------------|--|
| 7. | 50Ω DIVIDER/
OVERRIDE | The 50Ω DIVIDER indicator illuminates when an output voltage between 0 and 1.99999V dc or between 1 and 199.99 mV ac is selected to notify the operator the instrument has automatically changed to an internal precision 50Ω divider. The instrument also automatically reverts to internal sensing, if external had been selected. This divider can be overridden in the dc voltage mode by depressing the switch, which illuminates the OVERRIDE indicator. This holds the instrument in the 20 Volts range, dropping one or more digits; however, external sensing can be selected. If the amplitude of the output is changed while OVERRIDE is selected, the instrument remains in OVERRIDE provided the amplitude stays within the 0 to 1.99999 dc voltage figure. If it exceeds that it automatically reverts to its normal operation, i.e. both indicators extinguished; however, it remains in internal sensing. If external sensing is desired it must be reprogrammed, either manually or through the remote interface. |
|----|--------------------------|--|

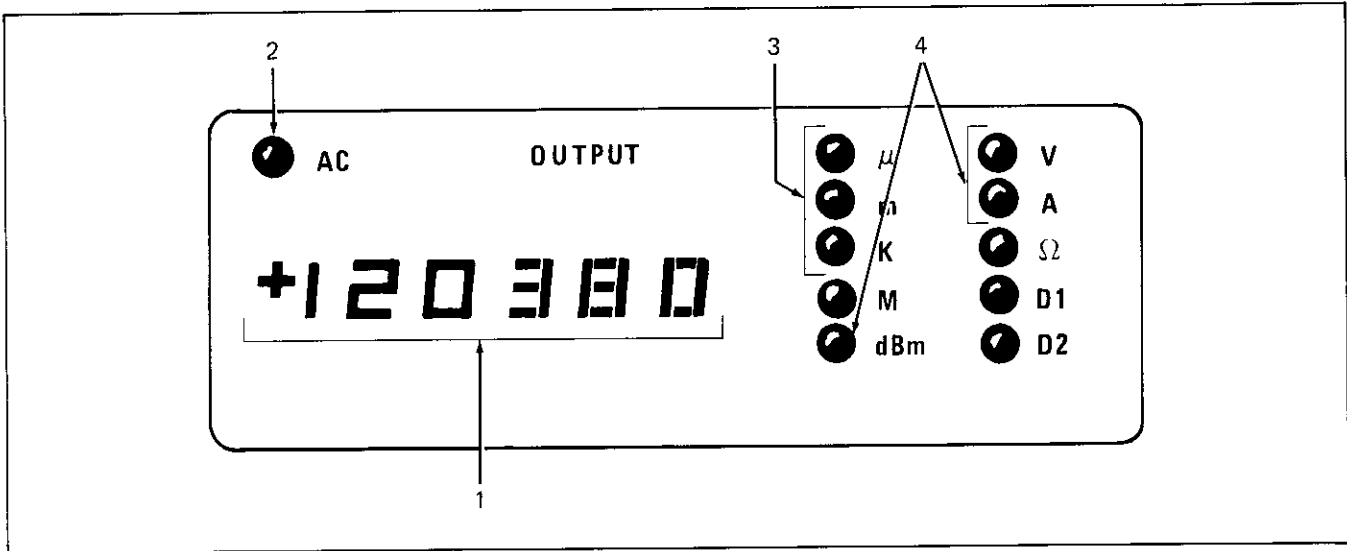

Figure 2-4. Output Display Group

Table 2-5. Output Display Group

1.	NUMERIC DISPLAY	The absolute numeric value with decimal point and polarity, if applicable, of the signal present at the output terminals.
2.	AC INDICATOR	Illuminated when the output signal is an AC Voltage of Current.
3.	MULTIPLIER	Indicator illuminates to show the multiplier of the numeric display. The multipliers are $\mu(10^{-6})$, $m(10^{-3})$, $k(10^3)$ and $M(10^6)$. Units (10^0) are the default condition with no indicator illuminated.
4.	FUNCTION	Illuminated to show whether the function displayed is Voltage (V), Current (A), Resistance (Ω), or decibel milliwatts (dBm). Indicators D1 and D2 are not used at this time.

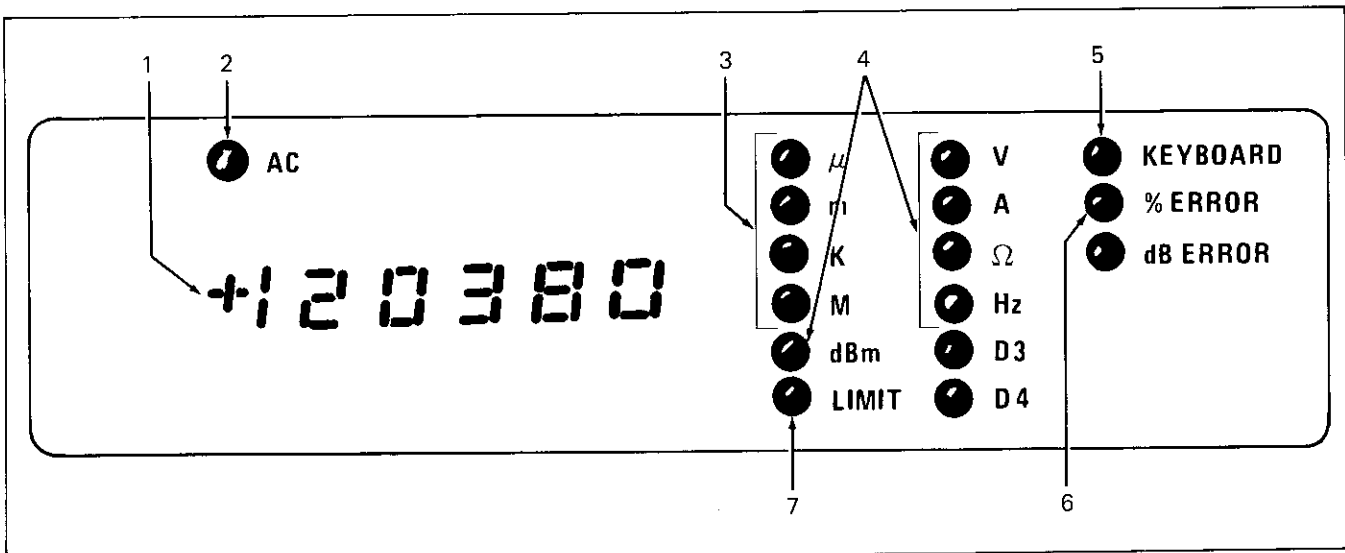

Figure 2-5. Central Display Group

Table 2-6. Central Display Group

1. NUMERIC DISPLAY	The absolute numeric value and polarity, if applicable, of the signal displayed.
2. AC INDICATOR	Illuminated when the displayed signal is an AC Voltage or Current.
3. MULTIPLIER	Indicator illuminates to show the multiplier of the numeric display. The exponents are u(10^{-6}), m(10^{-3}), k(10^3) and M(10^6). Units (10^0) are the default condition with no indicator illuminated.
4. FUNCTION	Illuminates to show whether the function displayed is Voltage (V), Current (A), Resistance (Ω), Frequency (Hz), or decibel milliwatts (dBm). Indicators D3 and D4 are not used at this time.
5. KEYBOARD	Illuminates when a "V", "A", " Ω " dBm, Hz, WIDEBAND, or EXT OSC entry is made from the DATA ENTRY group keyboard. Extinguishes when the data is entered into memory.
6. ERROR MODE INDICATORS	When the Output is modified to select the ERROR MODE the applicable indicator illuminates to define whether the displayed numeric is a percentage error or a dB error. The error is the difference between the original output as shown on the output display and the present output display, as modified by the error controls.
7. LIMIT INDICATORS	Illuminates when the displayed error exceeds the tolerance limit stored for that function. The indicator is a warning to the operator only. It does not effect operation of the instrument. The indicator also illuminates when either ENTRY LIMIT or TOL LIMIT is keyed as the initial step in storing a limit value or when the stored limits are recalled for observation.

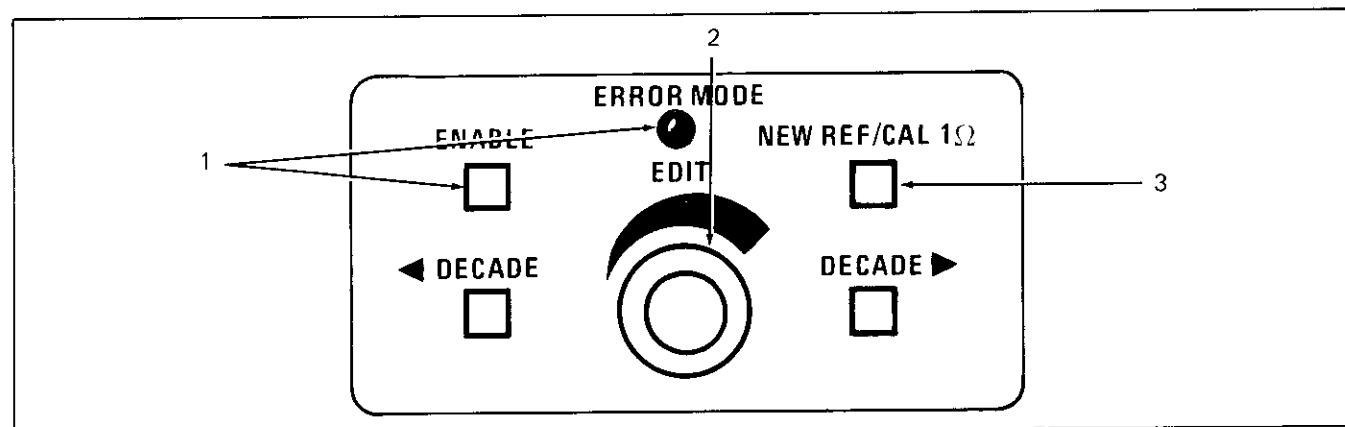

Figure 2-6. Error Mode Group

Table 2-7. Error Mode Group

1. ENABLE	The ENABLE switch toggles the instrument into or out of the Error Mode. When in the Error Mode the indicator illuminates. The Error Mode cannot be entered if the keyboard indicator is illuminated.
2. CONTROLS	The edit switch increments the absolute value (clockwise rotation) or decrements the absolute value (counterclockwise rotation) of the intensified digit on the output display (Central Display for Frequency modifications) when the error mode is selected. For example, a clockwise rotation will make a positive number more positive and a negative number more negative.

Table 2-7. Error Mode Group (cont)

<p>3. NEW REF/CAL 1 OHM</p>	<p>The left decade switch moves the intensified digit one decade to the left (toward the MSD) each time it is depressed. The right decade switch moves the intensified digit one position to the right (toward the LSD) with each depression. Continuing switch depressions when the digit has reached one extreme have no further effect.</p>
	<p>Changes the reference used in the computation of %ERROR or dB ERROR to the Value in the Output Display and resets the displayed error to zero. If the instrument is in the fractional scale mode, the full scale reference value is not changed. Used during internal sensed (2-wire) resistance measurements in the 1 ohm range to compensate the display resistance value for residual resistance.</p>

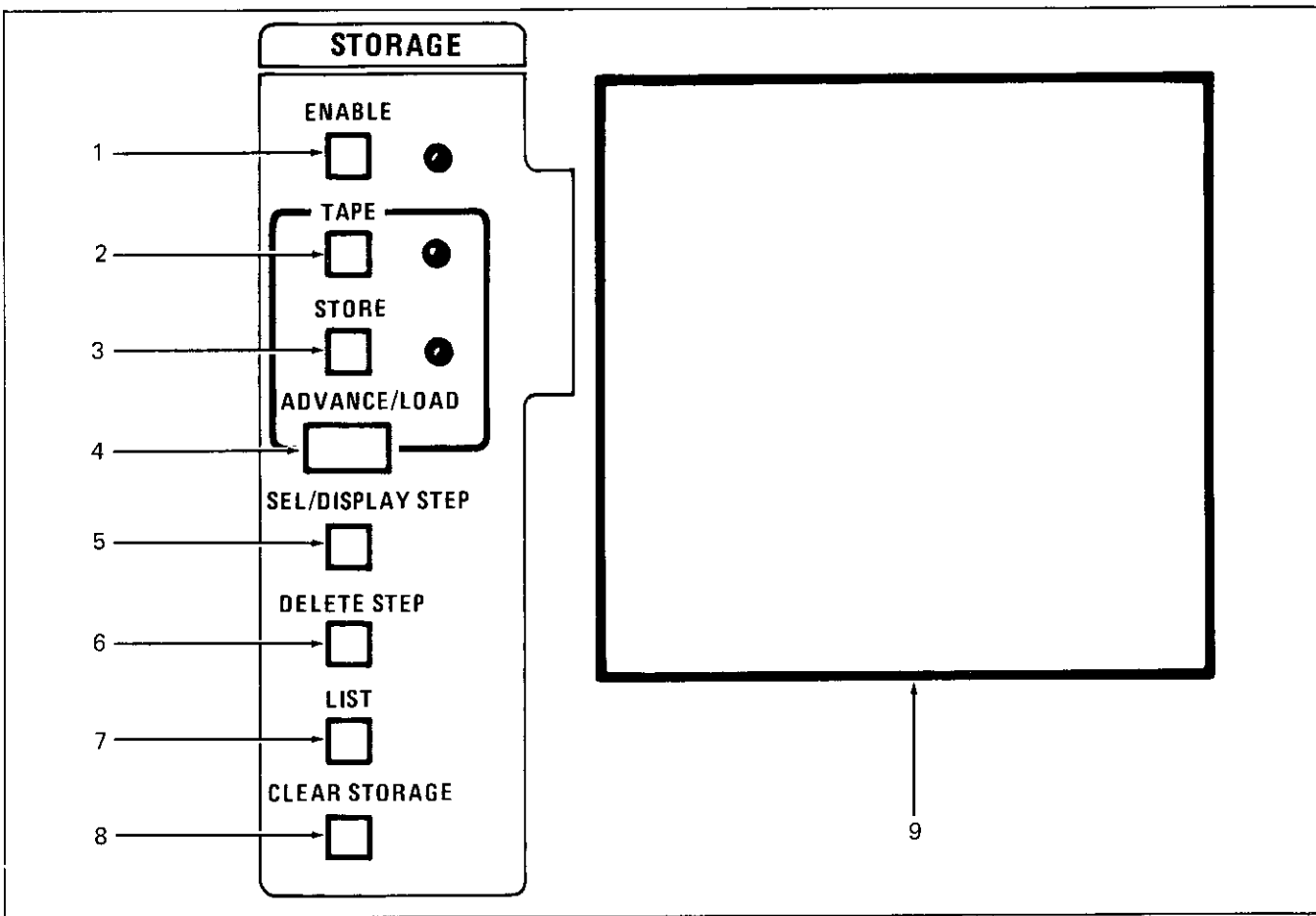

Figure 2-7. Storage Group (Storage Only)

Table 2-8. Storage Group (Storage Only)

<p>1. ENABLE</p>	<p>The ENABLE switch toggles the instrument into or out of, the storage mode of operation. The ENABLE indicator illuminates with the storage mode selected. Neither the tape system nor the memory can be used until the storage mode is selected.</p>
<p>2. TAPES</p>	<p>The TAPES switch is a toggle, enabling or disabling the Tape Mode. The TAPES indicator illuminates when the Tape Mode is selected.</p>

Table 2-8. Storage Group (Storage Only) (cont)

3	STORE	The STORE switch toggles the instrument between the Read and Store Modes. The Store Mode is selected when the indicator is illuminated. When the Store Mode is selected, data may be transferred from the instrument output to the Storage Memory or from the Storage Memory to Tape. The Read Mode is used to transfer data from a tape to the Storage Memory or from the Storage Memory to the instrument output.
4.	ADVANCE/LOAD	Operation of the ADVANCE/LOAD switch differs for the Read Mode, and Store Mode. When the Read Mode is selected and the switch is depressed, the next step in storage is transferred to the instrument output and the step number increments. When the final step has been selected, "End P", is displayed when the final step is loaded into the last step location. In the Store Mode, when the switch is depressed the output state is transferred to memory at the current step then the step number is incremented. After entering the final step for the capacity of memory, "End P" is displayed. If "FULL" is displayed, the memory buffer capacity would be exceeded and additional commands cannot be accepted.
5	SEL/DISPLAY STEP	Operation of the SEL/DISPLAY STEP switch is controlled by the operation preceding depression of the switch. If the operation is not preceded by the entry of a numerical value, the step number of the selected step is flashed on the Central Display. If preceded by a numerical entry, the action taken is dependent upon whether the Read or Store Mode is selected, if there is a program entered and whether or not the step selected is within an existing program. When the Read Mode is selected, the step number flashes then the stored output state is transferred to the instrument output. If the number selected is greater than the last step in the program, "End P", is displayed. In the Store Mode, the number selected is displayed, and that becomes the step referenced in storage operation. If the selected number is greater than the last step in the program the number of the first unused step is displayed and the final step is referenced. In the Store Mode the Output does not change when selecting or displaying steps.
6.	DELETE STEP	The step selected for operation is deleted when the DELETE STEP switch is depressed with the Store Mode selected. The step numbers of any subsequent steps are automatically decremented so there are no gaps in the sequence. The data replacing the deleted instruction is displayed. "Err 1", is displayed if the DELETE STEP switch is depressed with the Read Mode selected.
7.	LIST	Used with one of the Optional Interfaces to print an 80 column listing of of either all or part of the stored program (Store Mode) or the results of an individual test (Read Mode).
8.	CLEAR STORAGE	In the Store Mode all data in the storage memory is deleted and "End P", is displayed when the CLEAR STORAGE switch is depressed. If the switch is depressed in the Read Mode "Err 1", is displayed and no clearing action results.
9.	TAPE SYSTEM	Tape Unit to Read/Store data using a mini-cassette system, providing a permanent record of test programs

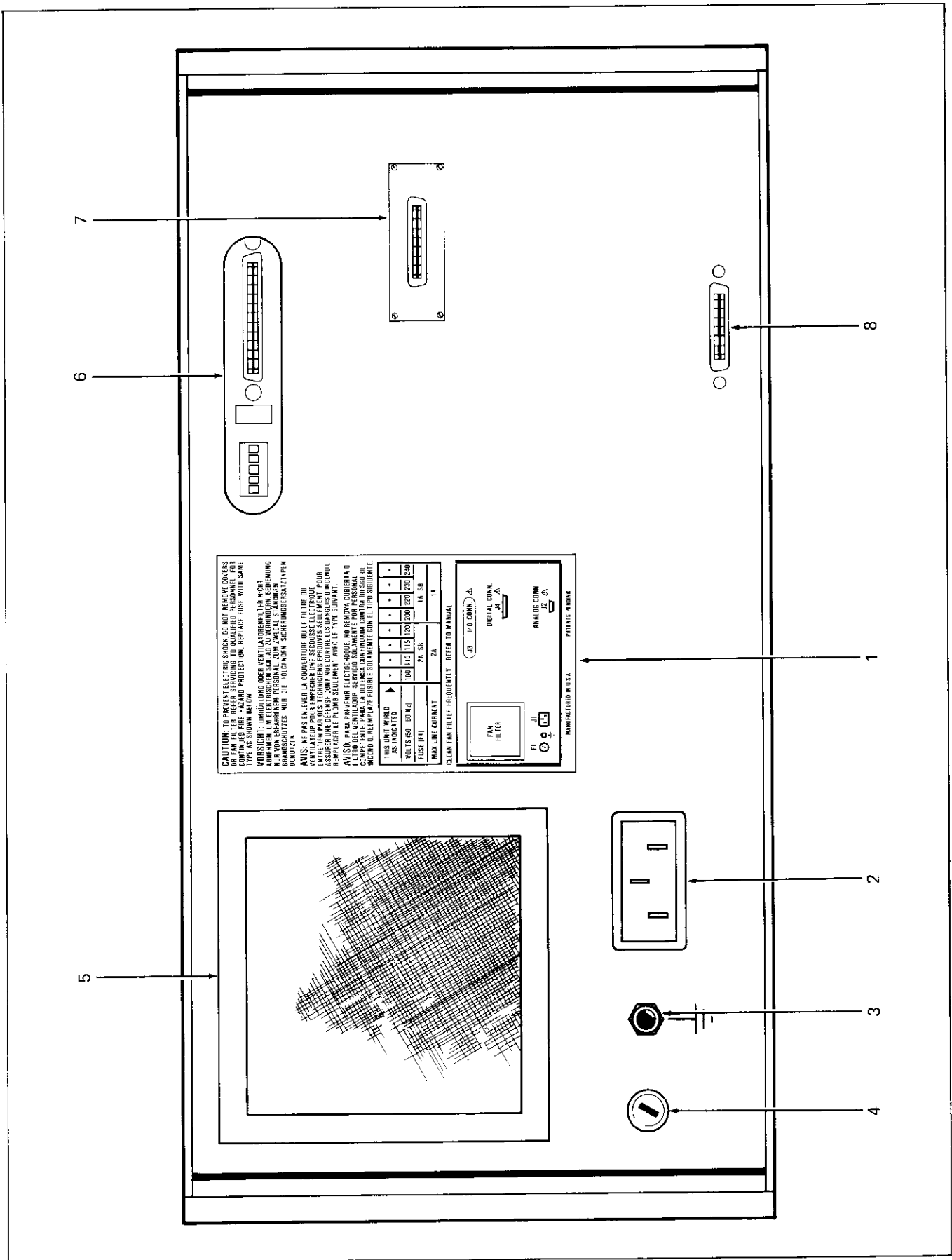

Figure 2-8. Rear Panel

Table 2-9. Rear Panel

1. Explanatory Decal lists set line voltage and nomenclature and/or identifiers for rear panel items
2. Input line power connector, J1
3. Chassis ground lug
4. Line power fuse, F1
5. Fan Filter. Refer to Section 4 for maintenance procedure
6. Interface Access slot. If one of the option interfaces is installed in the instrument, access to the connector and address controls, if any, will be available here
7. MIS Bus Connector
8. Analog Bus Connector. Inputs for the External Oscillator Signal, Oscillator Output, and Oscillator Output 90° are applied through the Analog Bus Connector, if required

Table 2-10. Error Codes

Err0	No error (status message only)
Err1	Invalid character or sequence
Err2	Invalid frequency or resistance entry
Err3	Programmed output exceeds entry limits or instrument capabilities
Err4	Invalid frequency/output combination
Err5 (Msg) O.L. (display)	Overload or overcompliance voltage
Err6	Module accessed inoperative or not installed—voltage greater than 20V programmed with high voltage output not installed
Err7	String command exceeds 32 characters
Err8	Tape load/feed problem or write protected
Err9	Unable to read the tape

2-37. To obtain a listing of the current output, select the Read Mode and List. The printed output includes the step number, programmed nominal output, tolerance programmed, the actual output error, and if that exceeds the programmed tolerance, the word FAIL. The placement of this data in the print format is shown in Figure 2-10.

2-38. Both types of listing(s) are preceded by a heading (see Figures 2-9 and 2-10). A heading may be obtained, subsequent to completion of the current line, by toggling the storage enable switch (two depressions) then depressing the list switch. A heading in progress can be terminated by entering a command.

2-39. All numeric data, except the tolerance limits for

both List Program and List Data, are printed in engineering notation. Only the exponents E-6, E-3, E3 and E6 are printed, the E0 entry is blanked.

2-40. Program Write-Protect (Storage Only)

2-41. Tapes recorded with a program destined for permanent storage may be protected from accidental erasure with the tape cassette write-protect feature. To obtain this feature, punch out the cross shaped plug (Figure 2-11) on the top back of the cassette as it is placed in the tape reader. After the plug has been removed an "Err8" results if an attempt is made to write additional data, or, write over the existing data on that side of the tape cassette.

HEADING			
DATA			
INSTRUMENT			
.			
STEP	OUTPUT & REFERENCE	LIMITS	STATUS
1.	2.	3.	4.
-----	-----	-----	-----
-----	-----	-----	-----

1. Program Step Number
2. OUT: Actual Output
NOM: Programmed Output (nominal)
FS REF: Full Scale value if the nominal is a fractional scale
3. TOL: Tolerance limits in percent of dB
ENT: Positive entry limit
Negative entry limit (printed only if applicable)
4. STDBY or OPR, EXT SENSE or INT SENSE
EXT OSC or WIDEBAND or 50Ω DIV OVRD (mutually exclusive) and BOOST
Position of the Error Cursor (1 for Output Display MSD down to 6 for the LSD and FREQ for frequency)

NOTE
If the second entry within a field is not used, subsequent entries within the field fill the vacated space.

Figure 2-9. LIST Program (Storage Only)

INSTRUMENT		SERIAL NO		
DATE		OPERATOR		
STEP	NOMINAL OUTPUT	TOLERANCE	ERROR	
1.	2.	3.	4.	5.

1. Step number of the program (Blank without a program in memory)
2. Nominal Programmed Output
3. Tolerance in Percent or dB
4. Actual Value of Error in Percent or dB
5. Prints ****Fail**** if the Actual Error Exceeds the Tolerance

Figure 2-10. LIST Data (Storage Only)

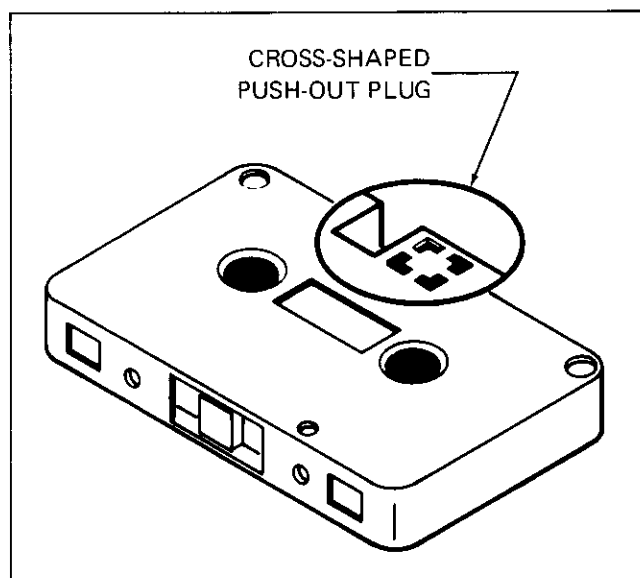

Figure 2-11. Tape Write-Protect Feature

2-42. LOCAL OPERATION

2-43. Initialization

2-44. The instrument is initialized when power is applied with the power switch, after having been removed, or when the CLEAR switch is depressed twice successively. This clears the registers and memory, extinguishing all the indicators except the following: STDBY, LOCAL, INT, AND 50Ω DIVIDER. In addition, the OUTPUT display reads 0.0000 mV and the Central Display flashes the number of the software revision, e.g., 1.0.5. The storage system, if installed, is not cleared by the CLEAR switch depressions.

2-45. Status During Function Change

2-46. In some cases the instrument automatically drops in status from Operate to Standby when the function is changed. These cases are listed in Table 2-11. When the status changes during a function change, depress the OPR/STDBY keyswitch to toggle the instrument back into Operate and continue with the procedure.

2-47. Meter Connection Procedure

2-48. Verify the instrument is in STDBY, then connect the meter to be calibrated to the Output terminals using the applicable configuration from Figure 2-12.

NOTE

Wideband AC Voltmeters (bandwidths exceeding 1 MHz) are susceptible to high-frequency noise on the low ranges and should be calibrated at levels below 10 mV using the Wideband (10 Hz-10 MHz) Output (Option -03).

Table 2-11. Standby/Operate Status Change

PRESENT FUNCTION	INSTRUMENT DROPS FROM OPR TO STDBY GOING TO THE FOLLOWING FUNCTIONS:
<20V dc	≥20V dc, ≥20V ac, A dc, A ac, Ohms
≥20V dc	≥20V ac, A dc, A ac, Ohms
<20V ac	≥20V dc, ≥V ac, A dc, A ac, Ohms
≥20V ac	≥20V dc A dc, A ac, Ohms
A dc	V dc, V ac, Ohms
A ac	V dc, V ac, Ohms
Ohms	≥20V dc, ≥20V ac, <20V dc, A dc, A ac
Wideband	≥20V dc, ≥20V ac, A dc, A ac
<20V dc, <20V ac:	Selected Output is less than 20V
≥20V dc, ≥20V ac:	Selected Output is equal to or greater than 20V

2-49. DC Voltage Output

2-50. Obtain a DC voltage output using the following procedure:

1. If the meter being tested is not connected, perform the connection procedure above.
2. Select the desired polarity and depress the applicable keyswitch.
3. Visible on the Central Display is the correct polarity.

NOTE

If a polarity is not selected, during DC operations, the instrument defaults to a positive polarity when the command is entered into memory.

4. Depress the numerical keyswitches required to obtain the absolute value of the desired voltage. Select in the normal sequence, i.e., from MSD (left) to the LSD (right).
5. The digits appear in the Central Display as they are entered with the LSD added on the right.
6. Select a multiplier, if required. If none is selected the instrument assumes units.
7. The selected multiplier indicator, if any, illuminates.

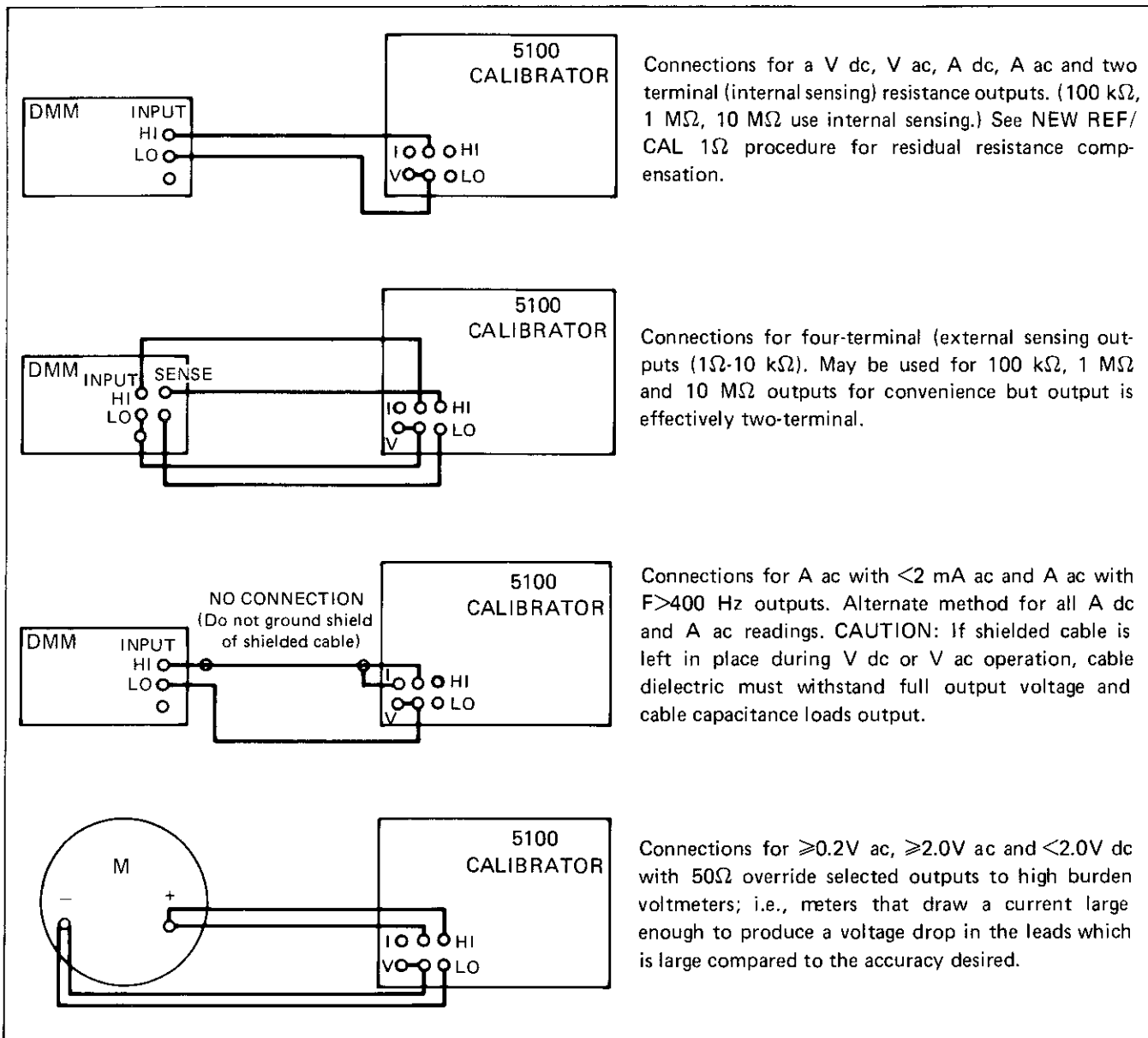

Figure 2-12. Meter Connections

8. Depress the V keyswitch to select volts.
9. The KEYBOARD and V indicators illuminate.
10. Depress the ENTER keyswitch.
11. The data visible on the Central Display transfers to the Output Display, blanking the Central Display.

NOTE

If the programmed output is 2.0 volts or greater the 50 OHM DIVIDER indicator automatically extinguishes.

12. Select OPR on the instrument, if required.

NOTE

If the current exceeds the capability of the calibrator, the Central Display flashes "O.L." and the instrument goes into STDBY.

13. The DC output may be altered by repeating the procedure starting at step 2.

2-51. AC Voltage Output

2-52. Obtain an AC voltage output using the following procedure:

1. If the meter being tested is not connected, perform the connection procedure above.

2. Depress the numerical keyswitches required to obtain the absolute value of the desired AC voltage. Select in the normal sequence, i.e., from the MSD (left) to the LSD (right).
3. The digits appear in the Central Display as they are entered, with the LSD being added on the right.
4. Select a multiplier, if required. If none is selected the instrument assumes units.
5. The selected multiplier indicator, if any, illuminates.
6. Depress the "V" keyswitch to select volts.
7. The KEYBOARD and V indicators illuminate.

NOTE

The output will be a DC voltage until a frequency is entered. The AC voltage may be altered without effecting the frequency by depressing ENTER and deleting the remaining steps of the procedure.

8. Depress the numeric keyswitches required to obtain the absolute value of the desired frequency. Select in the normal sequence, i.e., from the MSD (left) to the LSD (right).

NOTE

For a frequency entry the MSD is the only allowable significant digit.

9. The frequency entry appears on the Central Display.
10. Select a multiplier, if required. If none is selected the instrument assumes units.
11. The selected multiplier indicator, if any, illuminates.
12. Depress the Hz keyswitch.
13. The Central Display AC and Hz indicators illuminate.
14. Depress the ENTER keyswitch.
15. The frequency is displayed on the Central Display and the AC indicator on the Output Display illuminates.

NOTE

The frequency may be altered without entering the voltage into the instrument by deleting steps 1 through 7.

16. Select OPR on the instrument, if required, to obtain an output.

NOTE

If the output current exceeds the capability of the calibrator the Central Display flashes "O.L." and the instrument goes into STDBY.

17. Either the voltage or frequency can subsequently be altered without effecting the other.

2-53. Wideband Output

2-54. If the Wideband Option -03 is installed obtain an output at the wideband connector using the following procedure:

1. Depress the WIDEBAND switch.
2. The WIDEBAND indicator illuminates.

NOTE

Any voltage and frequency combination, within the specified limits of the Wideband Option, previously entered will be available for output. Any limits previously entered are still applicable.

3. Connect a 1 foot RG58/AU cable with BNC connectors between the wideband output connector and the receiving instrument.

NOTE

Any cable length greater than 1 foot will have an effect on the accuracy specifications. Refer to Section 6 of the instruction manual.

4. Select an AC voltage and frequency output, if required, as described above.

NOTE

Toggling the WIDEBAND switch and depressing the ENTER switch returns the instrument to standard operation.

2-55. Direct Current Output

2-56. Obtain a Direct Current Output using the following procedure:

1. If the meter being tested is not connected to the

instrument output terminals perform the connection procedure above.

2. Select the desired polarity and depress the applicable keyswitch.
3. Visible on the Central Display is the correct polarity.

NOTE

If a polarity is not selected the instrument defaults to a positive polarity when the command is entered into memory.

4. Depress the numerical keyswitches required to obtain the absolute value of the desired DC amps setting. Select in the normal sequence, i.e., from the MSD (left) to the LSD (right).
5. The digits appear in the Central Display as they are entered, with the LSD added on the right.
6. Select a multiplier, if required. If none is selected the instrument assumes units.
7. The selected multiplier indicator, if any, illuminates.
8. Depress the A keyswitch to select Current (Amps).
9. The KEYBOARD and A indicators illuminate.
10. Depress the ENTER keyswitch.
11. The command string visible on the Central Display transfers to the Output Display, blanking the Central Display. If the 50Ω indicator was illuminated from a prior setting it extinguishes.
12. Select OPR in the instrument, if required, to obtain an output.

NOTE

If the required compliance voltage exceeds the calibrator's capacity, the Central Display flashes "O.L." and the instrument goes into STDBY.

2-57. Alternating Current Output

2-58. Obtain an Alternating Current Output using the following procedure:

1. If the meter being tested is not connected to the instrument output terminals perform the connection procedure above.

2. Depress the numerical keyswitches required to obtain the absolute value of the desired AC amps setting. Select in the normal sequence, i.e., from the MSD (left) to the LSD (right).

3. The digits appear in the Central Display as they are entered, with the LSD added on the right.

4. Select a multiplier, if required. If none is selected the instrument assumes units.

5. The selected multiplier indicator, if any, illuminates.

6. Depress the A keyswitch to select Current (Amps).

7. The KEYBOARD and A indicators illuminate.

NOTE

The output will be in direct current until a frequency is entered. The alternating current may be altered without effecting the frequency by depressing ENTER and deleting the remaining steps of this procedure.

8. Depress the numeric keyswitches required to obtain the absolute value of the desired frequency. Select in the normal sequence, i.e., from the MSD (left) to the LSD (right).

NOTE

For a frequency entry the MSD is the only allowable significant digit.

9. The frequency entry appears on the Central Display.

10. Select a multiplier, if required. If none is selected the instrument assumes units.

11. The selected multiplier indicator, if any, illuminates.

12. Depress the Hz keyswitch.

13. The Central Display, KEYBOARD, AC, and Hz indicators illuminate.

14. Depress the ENTER keyswitch.

15. The frequency remains on the Central Display and the AC indicator on the Output Display illuminates.

NOTE

The frequency may be selected without entering the current into the instrument by deleting steps 1 through 7.

16. Select OPR on the instrument if required, to obtain an output.

NOTE

If the required compliance voltage exceeds the calibrator's capacity, the Central Display flashes "O.L." and the instrument goes into STDBY.

2-59. Resistance Output

2-60. Obtain a Resistance Output using the following procedure:

1. If the meter being tested is not connected to the instrument output terminals perform the connection procedure above.
2. Depress the numeric keyswitches required to obtain the absolute value of the desired resistance setting. Select in the normal sequence, i.e., from the MSD (left) to the LSD (right).

NOTE

Resistance entries may only be made from 1 ohm through 10 Megohms in multiples of power of ten (e.g., 10^0 , 10^1 , 10^2 , ..., 10^7).

3. The digits selected appear on the Central Display as they are entered.
4. Select a multiplier, if required. If none is selected the instrument assumes units.
5. The selected multiplier indicator, if any, illuminates.
6. Depress the Ω keyswitch to select Resistance (ohms).
7. The OHM indicator illuminates.

NOTE

If a low ohms value (10 kilohms and below) and internal sensing (two terminal) is selected, the Central Display flashes for one-half second "CAL 1Ω " when the ENTER switch is depressed. This display notifies the operator that he may compensate for the residual resistance encountered in low resistance, two-terminal calibration by performing the CAL 1 OHM procedure. This message is only displayed the first time low ohms is selected

after initial power applications or a RESET command. The CAL 1Ω display is blanked when the Resistance Value is entered into memory.

8. Depress the ENTER keyswitch.

9. The data visible on the Central Display transfers to the Output Display, blanking the Central Display.

10. Select OPR on the instrument, if required, to obtain an output.

2-61. dBm Output (AC Volts Only)

2-62. Obtain an output in decibels (i.e., 0 dBm is equal to 1 mW across 600 ohms for the main output terminals or across 50 ohms for the Wideband Option output) using the following procedure:

1. If the meter being tested is not connected to the instrument output terminals, perform the connection procedure above.
2. Obtain an AC output using the procedure above.

NOTE

The dBm entry below can be substituted for AC volts when obtaining an output.

3. Depress the numeric keyswitches required to enter the value of the desired dBm setting. Select in the normal sequence, i.e., from the MSD (left) to the LSD (right).
4. The frequency on the Central Display is blanked and the digits appear on the Central Display as they are entered, with the LSD added on the right.
5. Depress the dBm keyswitch.
6. The KEYBOARD and dBm indicators illuminate.
7. Depress the ENTER keyswitch.
8. The dBm value selected transfers to the Output Display and the frequency reappears on the Central Display.

NOTE

To determine the dBm output level in voltage, depress RECALL, V, ENTER, and the value will be displayed on the Central Display. Depress RECALL to toggle the instrument out of the Recall Mode.

2-63. Boost Mode Operation

2-64. Outputs can be obtained from either a Fluke Model 5205A/5215A Power Amplifier or 5220A Transconductance Amplifier to augment the calibrator capabilities by selecting the boost Mode. In addition to the Amplifiers named, a Y5000 5100 Series Interface Accessory and a cable for the applicable amplifier (Y5001 for the 5205A/5215A and/or Y5002 for the 5220A) are required.

2-65. The sequence of operations for the boost mode, using the Power or Current Amplifiers are listed below. Both amplifiers may remain connected to the calibrator, through the interface, while the calibrator is operating, however, only one can be selected and, therefore, operational, at a time.

2-66. POWER AMPLIFIER OPERATION

2-67. The Power Amplifier used may be either a Fluke Model 5205A or a Fluke Model 5215A. Either amplifier may be used to obtain AC voltage output, however, DC output can be obtained only from the Model 5205A.

2-68. Obtain a Boost Mode Power Amplifier output using the following procedure:

1. Insure power has been removed from both the calibrator and amplifier.
2. Connect the Y5000 Interface to the calibrator.
3. Connect the amplifier to the Calibrator Interface using the Y5001 Cable Assembly.
4. Apply power to both instruments and allow an adequate warmup period.
5. If the Model 5205A is used, select the REMOTE/5200 position.
6. Program a Boost Mode output from the calibrator by selecting in turn boost, output value data (100 to 1100 volts, and a frequency from 50 Hz to 50 kHz if AC), and ENTER.

NOTE

Selection of the BOOST keyswitch may either precede or follow entry of the Output Value Data without effecting operations, provided it precedes the selection of ENTER.

7. The BOOST indicator illuminates when the BOOST keyswitch is depressed, the voltage selected appears on the Calibrator Output Display, and the

frequency, if applicable, appears on the Central Display when the ENTER keyswitch is depressed. If a Model 5205A is used the 5200 indicator on the amplifier illuminates.

NOTE

If both the 5205A/5215A and 5220A are connected through the Y5000 the 5220A goes into REMOTE, STANDBY, and LOCAL LOCKOUT when ENTER is selected. This prevents accidental operation of the 5220A from the power amplifier drive signal on the 5205A/5215A rear panel.

8. Select OPR (operate) on the calibrator.

NOTE

When operating in the AC Mode the AC drive signal (up to 20V ac) for the Boost Amplifier is present on the Calibrator Output Terminals.

9. The OPERATE indicators of both the calibrator and amplifier illuminate and the programmed output value is available at the amplifier output terminals.

NOTE

Depressing BOOST, ENTER, while in the BOOST Mode will toggle the calibrator out of the Boost Mode, and return the output to the calibrator; however, at the greatly reduced power specifications of the basic instrument.

2-69. TRANSCONDUCTANCE AMPLIFIER OPERATION

2-70. The Fluke Model 5220A Transconductance (current) Amplifier is used to expand the capabilities of the calibrator up to 20 (19.9999) Amps. When connected to a 5100 Series B Calibrator through a Y5000 Interface and Y5002 Cable Assembly outputs can be programmed directly from the calibrator front panel.

2-71. Obtain a Boost Mode Current Amplifier Output using the following procedure:

1. Insure power has been removed from both the calibrator and amplifier.
2. Connect the Y5000 Interface to the calibrator.
3. Connect the amplifier to the Calibrator Interface using the Y5002 Cable Assembly.
4. Connect a load or current meter to the 5220A Outputs.

NOTE

The current selected multiplied by the load resistance must equal less than 3V rms or 4.2V dc to prevent a compliance trip of the equipment.

5. Apply power to both instruments and allow an adequate warmup period.
6. Program a Boost Mode Output from the calibrator by selecting in turn BOOST, Output Value Data (from a 0A dc or 2A ac to a maximum of 19.9999 Amps), and ENTER.

NOTE

Selection of the BOOST keyswitch may either precede or follow entry of the Output Value Data without effecting operation, provided it precedes the selection of ENTER.

7. The BOOST indicator illuminates when the BOOST keyswitch is depressed. The current selected appears on the Calibrator Output Display, and the frequency, if applicable, appears on the Central Display, when the ENTER keyswitch is depressed. The REMOTE and REAR INPUT indicators illuminate on the Current Amplifier front panel when the calibrator ENTER keyswitch is depressed.

8. Select OPR (operate) on the calibrator.

NOTE

When operating in the AC Mode the AC drive signal (up to 20V ac) for the BOOST Amplifier is also present on the calibrator Output Terminals.

9. The OPERATE indicators of both the calibrator and amplifier illuminate and the programmed output value is available at the amplifier output terminals.

NOTE

Depressing BOOST, ENTER while in the Boost Mode will toggle the calibrator out of the Boost Mode and return the output to the calibrator terminals; however, if an output greater than the capability of the calibrator, i.e. >1.99999A, has been programmed, an error results and an error message is displayed.

2-72. Enter Entry Limit

2-73. Place an Entry Limit in memory using the following procedure:

1. Depress the ENTRY LIMIT keyswitch.
2. The LIMIT indicator illuminates.

NOTE

Entry Limits may be set in either volts or amps at any value; however, the instrument will not exceed the values listed in the specifications. If a polarity is not assigned, the entry will be both positive and negative limits. If a polarity is specified, the other polarity remains unspecified until an entry is made.

3. Select the polarity, if desired, and depress the applicable keyswitch.
4. Visible on the Central Display is the correct polarity.
5. Depress the numeric keyswitches required to obtain the absolute value of the desired entry limits. Select in the normal sequence, i.e., from the MSD (left) to the LSD (right).
6. The digits appear on the Central Display as they are entered, with the LSD added on the right.
7. Select a multiplier, if required. If none is selected the instrument assumes units.
8. Select either volts (V) or amps (A).
9. The applicable indicator illuminates.

NOTE

The value of the Entry Limit is stored at this time; however, it is not compared against an existing value until the ENTER switch is depressed.

10. A value higher than the Entry Limit in memory cannot be entered until the Entry Limit is changed or cleared. Any attempt results in an Err3 display, which has no effect on the existing output. The value stored can be verified by using the Recall procedure described in a subsequent paragraph. In addition, if an entry limit is entered that is smaller than the programmed output, Err3 results. The error signal can be cleared by reprogramming the entry limit or the output, or by resetting (depressing CLEAR twice successively) the instrument.

2-74. Tolerance Limit Entry

2-75. Place the Tolerance Limit in memory using the following procedure:

1. Depress the TOL LIMIT keyswitch.
2. The LIMIT indicator illuminates.
3. Depress the numerical keyswitches required to obtain the absolute value of the limit percentage. Select in the normal sequence, i.e., from the MSD (left) to the LSD (right).
4. The digits appear on the Central Display as they are entered, with the LSD added on the right.
5. Depress the % keyswitch.
6. The % ERROR indicator illuminates.

NOTE

The tolerance limit is now entered into memory; however, it is not compared against an existing value until the Error Mode is entered. A percent of error greater than the entry during Error Mode operations causes the LIMIT indicator to illuminate and the numeric value on the Central Display to flash. This is a notice to the operator that the preset error limit has been exceeded. It does not effect the operation of the instrument.

2-76. Error Mode Operation

2-77. The Error Mode is used to find the deviation from a previously obtained output. This output may be in volts (DC or AC), Amps (DC or AC), ohms, Hertz, or decibels.

2-78. The Error Mode is entered by activating any of the rotary or keyswitches in the Error Mode Group. The Central Display immediately blanks any data displayed and substitutes zero error if the EDIT switch is rotated, if the NEW REF/CAL 1 OHM keyswitch is toggled, or if the ENABLE, ◀DECADE or DECADE▶ keyswitches are toggled (if cursor right decade is depressed to enter the Error Mode the frequency is displayed). If an internal calculation overflow results from exceeding the instrument's calculating ability or from a tolerance limit entry the Central Display will show "L Err" for large error. The data blanked from the Central Display is placed in temporary storage and redisplayed with the return to the normal mode. The instrument can be returned to the normal mode of operation by toggling the ENABLE keyswitch or by depressing any Front Panel keyswitch except the remaining Error Mode Group or OPR/STDBY.

2-79. VOLTS/AMPS ERROR MODE OPERATION

2-80. With the Volts/Amps measurements the output

signal is altered until the meter under test reads correctly. Therefore as the output magnitude goes higher it shows that a larger change is required to bring the test meter to the correct display and the percent of error is negative. The change in magnitude of the output is the inverse polarity of the percent of error.

2-81. Check the Volts/Amps Error Mode operation using the following procedure:

1. If the meter being tested is not connected to the instrument output terminals, perform the connection procedure above.
2. Obtain the desired base output using the applicable preceding procedure.
3. Place the instrument in the Error Mode using the procedure described in the preceding paragraph.
4. With the EDIT switch, modify the output until the meter under test reads the base setting of the output.
5. The Output Display reads the output required in volts or amps to obtain the required reading and the Central Display shows the difference from the base as a percentage.

2-82. OHMS ERROR MODE OPERATION

2-83. For an Ohms Error the Output Display is altered to match the reading of the test meter, and, as a result, the percentage of error is displayed. In this case, the percent increases or decreases with the change from the base and the display polarity has a direct relationship to the change of the output reading.

2-84. Check the Ohms Error Mode operation using the following procedure:

1. If the meter under test is not connected to the instrument output terminals perform the connection procedure above.
2. Obtain the desired base output using the applicable preceding procedures.
3. Place the instrument in the Error Mode using the procedure previously described.
4. With the EDIT switch, modify the Output Display until it corresponds to the reading of the meter under test.
5. The Central Display shows the percent of error in the meter under test.

2-85. FREQUENCY ERROR MODE OPERATION

2-86. The calibrator does not provide frequency error percentages. However, the Error Mode does allow the operator to quickly step through the frequency range of the instrument, checking the frequency response of the meter under test.

2-87. Check the Frequency Error Mode operations using the following procedure:

1. If the meter under test is not connected to the instrument output terminals perform the connection procedure above.
2. Obtain the desired base frequency using the applicable procedure.
3. Depress the DECADE ► keyswitch to place the instrument in the Error Mode and move the cursor over the MSD (only digit accessible for modification) of the frequency.
4. With the EDIT switch modify the frequency as desired.

2-88. dBm ERROR MODE OPERATION

2-89. In the dBm Error Mode the displayed error is in dB rather than a percentage. Modification to the base figure is in dBm and the error on the Central Display is changed accordingly.

2-90. Check the dBm Error Mode operation using the following procedure:

1. If the meter under test is not connected to the instrument output terminals, perform the connection procedure above.
2. Obtain the desired base output in dBm using the applicable procedure.
3. Place the instrument in the Error Mode using the procedure described above.
4. With the EDIT switch, modify the base output until the meter under test reads the desired setting.
5. The Output Display reads the dBm required to obtain the proper reading and the Central Display shows the difference from the base in dB.

2-91. NEW REF/CAL 1Ω Operation

2-92. This switch performs two different functions, dependent upon the status of the instrument. The New Reference function is available any time the instrument is

in the Error Mode, while the CAL 1 OHM function requires that 1 ohm resistance be selected also. The sequence of operations for each is given below.

2-93. NEW REFERENCE OPERATION

2-94. If the keyswitch is depressed when the instrument is in the Error Mode, the output, as modified by the edit feature of the error mode, becomes the new base except in the Fractional-Scale Mode when the full-scale reference is not changed. Error Mode modifications and percent of error figures will be on the new base established with the NEW REF/CAL 1Ω keyswitch.

2-95. CAL 1Ω OPERATION

2-96. This feature is used to compensate for the residual resistance during two-terminal (internal sensing) operations. Use the following procedure for the CAL 1Ω sequence:

1. Connect the test ohmmeter using the two-terminal method.
2. Select internal sensing and program a 1Ω output from the instrument.
3. Use the Error Mode and modify the instrument output until it reads the same as the meter under test.

NOTE

The meter under test must be reasonably accurate ($\pm 1\%$) and must read between 1.00000 and 1.99999 ohms for the CAL 1Ω feature to operate.

4. When the instrument output and the meter under test read the same, depress the NEW REF/1 OHM CAL keyswitch.
5. The residual resistance is automatically added to any resistance range selected up to 10 kilohms, as long as the resistance function is selected, it remains on internal sense, and the instrument is not reset by either removing power or a CLEAR ALL command, or until a new value of residual resistance is entered.

NOTE

If the switch is depressed when the instrument display is greater than 1.99999 ohms, a correction of zero ohms is stored. In addition, the instrument operates as in the NEW REF mode described above.

2-97. Fractional-Scale Operation

2-98. Fractional-Scale Operations allow the operator to output and modify for Error Mode operations some fractional value of the base output while the displayed error is computed on the original value. (Fractional scale entries must be in units; multiplier, i.e., exponents cannot be used.) It is intended for use with a meter under test that has its accuracy at fractional-scale magnitudes specified as a percent of full-scale. When a fractional-scale entry results in a Err3 or Err4 an erroneous output value results from the programmed fraction. Programming a valid output or resetting the instrument will remove the error. The procedure in the following example demonstrates how the percentage of error is computed on a 12 volt base rather than on a 9 volt output obtained with the $\frac{3}{4}$ fractional-scale entry. The fractional-scale feature cannot be used when the instrument is in the Keyboard Mode.

1. Obtain an output of 12 volts using the DC volts output.
2. Depress the Data Entry Group keyswitches "3./4," to make the fractional-scale entry.
3. The Central Display shows "3-4".
4. Depress the ENTER keyswitch.
5. The Central Display blanks and the Output Display is altered to read +9.0000 volts.
6. Rotate the EDIT switch clockwise for an Output Display of +9.0001.
7. The Central Display reads -.0008 and the %ERROR indicator is illuminated.

NOTE

A change of .0001 at 9 volts base would read -.00111 ($0.0001/9 = -.0011\%$) while the same change with a 12 volt base would read the -.0008 displayed.

2-99. Entries can be made for any function except dBm or ohms. The entries may also be altered by making a new fractional-scale entry. For example: using the above example if $\frac{1}{2}$ was entered the output display would change to 6.000, $\frac{3}{4}$ would change it to 3.000 and 1/1 would change it back to 12.000. As you can see, all entries have made their change based on the original 12 volts, not on the current output. If at some time during the procedure it is desired to change the base to the current output, it can be accomplished by depressing the NEW REF CAL 1 OHM keyswitch. If the ENTER switch is depressed without entering a valid fraction, the instrument drops out of the Fractional Scale Mode.

2-100. External Oscillator Operation

2-101. Desired frequencies that are outside the capability of the instrument, i.e., more than one significant digit or more accurate, can be obtained using the External Oscillator feature. The external frequency must be within the range of the standard 5100 Series (50 Hz to 50 kHz) at 1.2V rms $\pm 5\%$ and an output impedance no greater than 50 ohms. The signal is input to the instrument at pin 4 (EXT OSC) and 7 (OSC COM) of J2, the Analog Connector on the Rear Panel.

NOTE

Matching connectors to meet the customer's particular needs are available from Fluke or the manufacturer. For example, a straight-in hooded 14-pin male connector can be ordered from Fluke using Part Number 272443. The Federal Supply Code is 02660 and the Manufacturer's Part Number is 57-30140.

2-102. Certain limitations are placed on external frequency/programmed voltage combinations when maximum performance is required. These limits are listed in Table 2-12. Other combinations may be programmed, at the user's discretion; however, the performance will be degraded and the instrument may go into Overload ("O.L."). No damage will result to the instrument from the overload condition.

NOTE

Amplitude instabilities, distortion, noise, etc., of the external oscillator can appear at the instrument output.

Table 2-12. External Frequency/Voltage Limitations

EXTERNAL FREQUENCY	PROGRAMMED AC VOLTAGE
50 Hz – 1 kHz	1100V
> 1 kHz – 20 kHz	110V
> 20 kHz – 50 kHz	19.9999V

2-103. Operate with the external oscillator using the following procedure:

1. Connect the external oscillator signal to J2 on the rear panel, insuring it is within the frequency, voltage, and impedance limits as stated above.
2. Depress the EXT OSC keyswitch to select the external oscillator function.
3. The KEYBOARD and EXT OSC indicators illuminate.

4. Program the desired output voltage or current.
 5. Program a frequency within one of the brackets in Table 2-13 to match the input frequency.
 6. Depress the ENTER switch.
 7. The programmed voltage and frequency are displayed and the KEYBOARD indicator extinguishes.
 8. Select OPR, if required.
5. Depress the keyswitch for the applicable function, i.e., V, A, Hz, etc.
 6. The recalled data is displayed on the Central Display with any previously displayed data stored and blanked from the display.
 7. Toggling the instrument out of the Recall Mode, by depressing the RECALL keyswitch, blanks the recalled data and returns the stored, previously displayed, data to the Central Display.

Table 2-13. External Oscillator Frequency Ranges

OUTPUT	INPUT FREQUENCY	PROGRAM THE FREQUENCY BETWEEN
Volts	50 Hz to 1999 Hz	50 Hz to 1000 Hz
Volts	2 kHz to 20 kHz	2 kHz to 20 kHz
Volts	20 kHz to 50 kHz	30 kHz to 50 kHz
Amps	50 Hz to 1000 Hz	50 Hz to 1000 Hz

2-104. Recall Operations

2-105. With the instrument toggled into the Recall Mode, data stored in memory can be recalled and displayed on the Central Display. The stored values for voltages (V), current (A), frequency (Hz), resistance (Ω), decibels (dBm), dBm equivalent voltage, Entry Limits, or Tolerance Limits, in the applicable polarity, can be displayed. Depression of an illegal keyswitch toggles the instrument out of the Recall Mode. If a numeric key is depressed, "Err1" is displayed and the entry is ignored; however, the instrument is toggled out of Recall. Toggle the RECALL key prior to a numeric entry to preclude the error message, or, if already displayed, reenter the numeric or depress CLEAR one time to resume operations.

2-106. Perform the Recall operation using the following procedure:

1. Toggle the instrument into the Recall Mode with the RECALL keyswitch.
2. The RECALL indicator illuminates.
3. If a Limit value (ENTRY LIMIT or TOL LIMIT) is to be recalled, depress the applicable keyswitch(s). The appropriate indicator illuminates. The tolerance limit is displayed, if selected.
4. If a polarity is required depress the applicable keyswitch. The polarity indication appears on the Central Display.

NOTE

Depressing RECALL clears the keyboard memory of any data stored and extinguishes the KEYBOARD indicator, if illuminated.

2-107. Storage System Operations (Storage Only)

2-108. The following set of procedures are for the operation of the Storage System and its integral Tape System. In all cases, the Storage Mode must be selected by depressing the ENABLE switch so that the ENABLE indicator illuminates. If the Tape System is to be used, a tape cassette must be loaded into the Tape System.

CAUTION

Tapes used must be certified digital mini-cassettes that conform with the ANSI Standard X3B5/77-49. Audio tapes will not give acceptable results.

NOTE

Do not attempt to load a tape with any Standard Analog PCB Assemblies removed, except the Extended High Voltage Assembly. The display will blank and the instrument must be reset.

2-109. CREATING A STORAGE SYSTEM PROGRAM (STORAGE ONLY)

2-110. The following routine is an example of a simple program that can be used to become familiar with the procedures required to enter a program into memory and then transfer it to tape storage. A detailed description of all the routines available follows in the ensuing paragraphs. Load the example program using the following procedure:

1. Insert the tape, on which the program is to be written, into the tape system.
2. Select the ENABLE and STORE keyswitches.

3. The ENABLE and STORE indicators illuminate.

4. Select, in turn, the 1, V, ENTER, ADVANCE/LOAD keyswitches.

NOTE

Any legal function or control can be included in the command, e.g., Standby/Operate, Internal/External Sense, etc; however, for safety reasons step 001 always comes up in STANDBY.

5. The Output Display reads 1.00000V and the Central Display flashes the number "002" to indicate that new data will be placed in step 2.

6. Select the 2, V, ENTER, ADVANCE/LOAD keyswitches.

7. The Output Display reads 2.00000V and the Central Display flashes 003.

8. Continue the sequence using 3, 4, 5, etc, volt entries for as many steps as desired.

9. Select the TAPE keyswitch.

10. The TAPE indicator illuminates.

11. Select ADVANCE/LOAD.

12. The loaded tape rewinds, runs forward to load the data, and rewinds again.

13. The Output Display reads 1.00000V, the Central Display flashes 001 and the TAPE and STORE indicators extinguish.

14. Select the 3, SEL DISPLAY STEP keyswitches.

15. The Output Display reads 3.00000V, i.e., the programmed output for step 3 and the Central Display flashes 003.

16. Select ADVANCE/LOAD.

17. The Central Display flashes the number of the next step in sequence and the Output Display reads the value of the of the step, i.e., 4.00000V.

18. Step through the program until the Central Display reads "END P" signaling the end of the program. At each step the Central Display should flash the number of the step and the Output Display read the value stored.

19. Select the ENABLE keyswitch to toggle out of the Enable Mode and disable the storage system, and return to standard operations when desired.

2-111. DISPLAY THE STEP LOCATION SELECTED (STORAGE ONLY)

2-112. Use the following procedure to display the number of the selected step on the Central Display:

1. Depress the SEL/DISPLAY step switch.
2. The number of the step selected flashes on the Central Display, holds for approximately one second, then the display returns to its prior state.

2-113. SELECT A STEP - READ MODE (STORAGE ONLY)

2-114. Use the following procedure to select a predetermined step while in the Read Mode:

1. Verify the Read Mode is selected, i.e., the STORE indicator is extinguished.
2. Select the number of the desired step with the numeric switches in the data entry group.
3. The number entered appears on the Central Display.
4. Depress the SEL/DISPLAY STEP switch.
5. The number of the step selected flashes on the Central Display for approximately one second, then the state stored in that location is transferred to the instrument output. "End P" is displayed if the selected step is beyond the end of the current program.

NOTE

The instrument status might drop from OPR to STDBY with the change in state of the selected output. Refer to Table 2-11 for a list of the operational status requiring a change in status.

2-115. SELECT A STEP - STORE MODE (STORAGE ONLY)

2-116. Use the following procedure to select a predetermined step while in the Store Mode:

1. Select the Store Mode with the STORE switch.
2. The STORE indicator illuminates.

3. Select the number of the desired step with the numeric switches in the Data Entry Group.

4. The number entered appears on the Central Display.

5. Depress the SEL/DISPLAY STEP switch.

6. The memory moves to the step location selected, provided it is within the existing program. If not, it steps to the first location available for data entry. The selected step number is flashed on the Central Display for approximately one second, then the output returns to its original state.

2-117. READ OUTPUT STATE (STORAGE ONLY)

2-118. Read an output state previously stored in memory using the following procedure:

1. Perform the Select a Step (Read Mode) procedure previously described, using the number of the step to be read.

2. Depress the ADVANCE/LOAD switch.

3. The state is transferred to the output of the instrument and its appropriate step number is displayed for approximately one second, followed by the display of the output condition.

2-119. STORAGE OUTPUT STATE (STORAGE ONLY)

2-120. Store an output state in memory using the following procedure:

1. Select the Store Mode with the STORE switch.

2. The STORE indicator illuminates.

3. Verify the state to be stored has been programmed into the instrument.

NOTE

The desired state can be programmed into the instrument at this time or at any time prior to selecting the storage mode of operation.

4. Depress the ADVANCE/LOAD switch.

5. The number of the next step in sequence flashes on the Central Display for approximately one second, then the display returns to its previous state. "End P" is displayed if the step stored fills the memory.

NOTE

"FULL" is displayed when the memory is full and the step cannot be loaded.

2-121. DELETE INSTRUCTION (STORAGE ONLY)

2-122. Use the following procedure to delete a previously entered instruction:

1. Perform the Select a Step (Store Mode) procedure previously described using the number of the step to be deleted.

NOTE

Instrument must be in the Store Mode.

2. Depress the DELETE switch.

3. The step number deleted flashes on the Central Display for approximately one second. All subsequent steps move up one number and the step moved into the step just deleted is transferred to the output.

2-123. TRANSFER STORAGE MEMORY TO TAPE (STORAGE ONLY)

2-124. Transfer the instructions stored in memory to a tape for a permanent record using the following procedure:

1. Insure a tape cassette is loaded in the Tape Reader then select the Tape Mode with the TAPE switch.

2. The TAPE indicator illuminates.

3. Select the Store Mode with the STORE switch.

4. The STORE indicator illuminates.

5. Depress the ADVANCE/LOAD switch.

NOTE

If the unit was in OPR (Operate), it will drop in status to STDBY (Standby).

6. The tape advances.

7. When the transfer of data is complete, the TAPE and STORE indicators automatically extinguish and the tape stops. There is no change in the data displayed or stored in memory except the instrument remains in STDBY.

2-125. TRANSFER TAPE RECORD TO STORAGE MEMORY (STORAGE ONLY)

2-126. Transfer the data stored on a tape to the storage group memory using the following procedure:

1. Insure the tape cassette containing the program to be transferred is loaded in the Tape Reader, then select the Tape Mode with the TAPE switch.
2. The TAPE indicator illuminates.
3. Verify the Read Mode is selected, i.e., the STORE indicator is extinguished.
4. Depress the ADVANCE/LOAD switch.

NOTE

If the unit was in OPR it will drop in status to STDBY.

5. The tape advances.
6. When the transfer of data is complete, the TAPE indicator extinguishes automatically, the tape drive stops. Step 1 is transferred to the output, and step "1" flashes on the Central Display, followed by display of the data in Step 1 on the Output Display and the Central Display, if applicable.

2-127. LIST PROGRAM STEPS (STORAGE ONLY)

2-128. Use the following procedure to obtain a permanent printed copy of a program entered into storage memory. An optional remote interface must be installed in the instrument to use this feature.

1. Perform the Select a Step (Store Mode) procedure previously described, using the first number of the desired listing.
2. Depress the LIST switch.

NOTE

If the unit was in OPR it will drop in status to STDBY.

3. The program, or selected portion, is transferred through the optional remote interface to a printing device.

NOTE

The listing is terminated if a front panel switch is depressed or a command is input through the remote interface.

2-129. LIST DATA (STORAGE ONLY)

2-130. Use the following procedure to obtain a permanent printed copy of the test data. An optional remote interface must be installed in the instrument to use this feature.

1. Verify the Read Mode is selected, i.e., the STORE indicator is extinguished.
2. Depress the LIST switch.
3. The single test step at the output is transferred through the remote interface to the printing device.

2-131. CLEAR STORAGE MEMORY (STORAGE ONLY)

2-132. Use the following procedure to clear the storage memory:

1. Select the Store Mode with the STORE switch.
2. The STORE indicator illuminates.
3. Depress the CLEAR STORAGE switch.
4. Any data stored in memory is erased and the Central Display flashes "End P" then returns to its prior state.

2-133. REMOTE OPERATION

2-134. The 5100 Series B can be remotely programmed through either the IEEE 488-1975 Standard Interface Option (-05) or the Bit Serial Asynchronous (RS-232-C) Interface Option (-06), described in Section 6 of the instruction manual. Communication between the controlling device and the instrument interface must be in the standard ASCII codes. The codes accepted by the instrument and a brief explanation of each is given in Table 2-14.

2-135. When one of the optional interface modules is installed in the instrument the Remote Mode can be activated either manually or from the Control Device. The instrument can be placed in remote through the IEEE-488 Interface by addressing it with the address assigned to the instrument. Remote can be accomplished through the Bit Serial Interface by programming the character "J" as described in later paragraphs. The instrument is put in remote from the front panel by toggling the REMOTE switch. Unless the front panel is disabled or "locked out" by a remote command it can return the instrument to local operation by toggling the REMOTE switch on the front panel.

Table 2-14. Programming Codes

CODE	EXPLANATION	CODE	EXPLANATION
	INITIATION CHARACTERS		STORAGE COMMANDS (Storage Only)
*	Reset – go to local	Q1	Enable Storage Mode
C	Clear Entry	Q0	Disable Storage Mode
CC	Reset – stay in remote	[1	Enable Tape Mode
LC	Clear entry limits	[0	Disable Tape Mode
TC	Clear tolerance limits	W1	Select Store Mode
I0-3	Interface Interrupt Enable Codes	W0	Select Read Mode
Y0-7	Interface Output Enable Codes	&	Advance/Load
.	Termination Character	(Select/Display Step
	CONTROL COMMANDS)	Delete Step
J	Go to Remote - RS232	K	List
#	Go to local – RS232	=	Clear Storage
U1	Enable Local Lockout		DATA INSTRUCTIONS
U0	Disable Local Lockout		
S	Go to Standby	+,-	Polarity entry
N	Go to Operate	0-9	Magnitude entry
X1	* Select external sensing	.	Decimal point
X0	* Select internal sensing	/	Fractional scale entry
F1	* Enable external oscillator mode	E	Exponent entry follows
F0	* Disable external oscillator mode	V	* Volts entry
R1	* Select 50 ohm divider override	A	* Amps entry
R0	* Disable 50 ohm divider override	Z	* Ohms entry
@	Error Mode toggle	H	* Hertz entry
<	Error Mode Cursor one position left	D	* dBm entry
>	Error Mode Cursor one position right	%	Percentage entry
:	Increment digit under cursor		STATUS
:	Decrement digit under cursor		
\$ or '	Store NEW REF/CAL 1 ohm reference	! or "?	Print Status message
G	Recall	?	Print Central Display
L	Enable Entry Limit entry		
T	Enable Tolerance Limit entry		
P1	* Enable Wideband option		
P0	* Disable Wideband option		
B1	* Enable Boost Mode		
B0	* Disable Boost Mode		*Terminator required for action

2-136. Programming instructions may be either initiation or string commands. The initiation commands are one or two character messages that are operated on as soon as they arrive unless they are part of a string, in which case they are executed in sequence within the string. The only exception is reset, which has an immediate response. String Commands can be Control Commands, Storage Command (used with the 5101B only), Data Instructions, Status requests, or a combination of the first three, and are sent in a series of 1-to-32 characters that are, with the exceptions noted in the text, concluded with a terminator character.

2-137. Initiation Characters

2-138. RESET "*"

2-139. The instrument is reset to the initial sequence and Local Mode with this instruction. It assumes the default condition, i.e., all registers reset. The visible effect on the instrument is the STDBY, LOCAL, INT, and 50Ω DIVIDER indicators illuminated and the Output Display set to 0.0000 mV dc. In addition, the Wideband, External Oscillator, Echo Capability, and Line Feed Suppression features are disabled and the IEEE-488 Service Request disabled.

NOTE

Allow a 500 ms interval between a Reset command "" and any subsequent command.*

2-140. CLEAR "C"

2-141. A single "C" entry during a numeric entry while in the Keyboard Mode clears that entry. A second successive "C" entry clears the instrument to its initial state except it remains in remote. When the "C" is directly preceded by an "L" entry the programmed entry limits are set to their maximum setting. The entry "TC" sets the tolerance limits to maximum tolerance.

2-142. INTERFACE INTERRUPT ENABLE CODES

2-143. Interrupts for the interface system are generated using the alpha character I followed by an octal number between 0 and 3, inclusive. The numeric is based on the three binary bits of an octal number with bit 0 high if the interrupt (Service Request SRQ in the IEEE-488 Interface) is enabled with a "Ready", and bit 1 high if enabled with an "Error". "Ready" interrupt refers to a SRQ at the end of a timeout which represents the maximum settling time required in the programmed range. They are generated after a command which causes a change in output, e.g., a terminator or Standby/Operate Command. Bit 2 is not used at this time so the available codes extend only to an octal 3. The possible combinations are given in Table 2-15.

Table 2-15. Interface Interrupt Codes

NUMERIC	INTERRUPT ON	
	READY	ERROR
0	Disabled	Disabled
1	Enabled	Disabled
2	Disabled	Enabled
3	Enabled	Enabled

2-144. INTERFACE OUTPUT CODES

2-145. Outputs for the interface system are generated using the alpha character I followed by an octal numeric between 0 and 7, inclusive. The numeric is based on the three binary bits of an octal number with bit 0 high to suppress alphabetic character output, bit 1 high to enable the echo feature of the RS-232-C Interface, and bit 2 high to disable the automatic line feed following a carriage return. The possible combinations are given in Table 2-16.

Table 2-16. Interface Output Codes

NUMERIC	ALPHA CHARACTER OUTPUT	RS232 ECHO CAPABILITY	AUTO LINE FEED AFTER CARRIAGE RETURN
0	Active	Disabled	Enabled
1	Suppressed	Disabled	Enabled
2	Active	Enabled	Enabled
3	Suppressed	Enabled	Enabled
4	Active	Disabled	Disabled
5	Suppressed	Disabled	Disabled
6	Active	Enabled	Disabled
7	Suppressed	Enabled	Disabled

2-146. TERMINATOR ","

2-147. The character "," (comma) is entered to complete a string of commands and is notice to the controller to execute the preceding commands back to the previous terminator.

2-148. String Commands

2-149. There are four types of commands that can be used within a string. They consist of entries to program Control Commands, Tape Commands (used with Storage Units only), Data Instructions, or to request a return statement on Status. The Control Commands, Tape Commands, and Data Instructions can be combined in a single string, provided the string does not exceed 32 characters in length, including the terminator.

2-150. CONTROL COMMANDS

2-151. Control Commands are used to program the modes of operation. The codes are used to enable or disable the modes of operation. Multiple modes may be enabled in one command string. The Control Commands are given in the following paragraphs.

2-152. Interface Commands

2-153. The IEEE 488-1975 Interface is enabled with an address character which is further defined in the Standard and Section 6 of the instruction manual. The RS-232-C Interface is enabled with the character "J" and disabled and returned to Local control with the character "#". The characters "UI" lockout the LOCAL REM switch on the Front Panel for a Local Lockout condition, preventing a return to Local from the Front Panel. The Local Lockout is disabled, allowing free use of the Front Panel with the instruction "U0". The Local Remote commands are acted on immediately, not requiring a terminator.

2-154. Standby/Operate

2-155. Standby is enabled with the character "S". Operate is enabled with the character "N". The modes are mutually exclusive so the opposite mode is automatically disabled. The Standby/Operate commands do not require a terminator for action.

2-156. Sensing

2-157. External sensing is selected with the instruction "X1". Internal sensing with "X0". A terminator is required for execution.

2-158. External Oscillator

2-159. The External Oscillator Mode is selected with the instruction "F1". To return to the internal oscillator, program "F0". A terminator is required for execution.

2-160. 50 Ω Divider Override

2-161. The Override Mode is programmed with the characters "R1". This mode does not allow the instrument to go into DC voltage ranges below 20 volts (minimum normal reading 2.0000). An output of 1.00000 or less has a normal output impedance of 50 ohms. The override may be disabled while remaining in the DC Volts with the instruction "R0". Programming a reading above 2.0000V dc, or an output with any function except DC volts selected automatically, disables the override. A terminator is required for execution.

2-162. Error Mode Instructions

2-163. Programming any of the six Error Mode instructions puts the instrument into the Error Mode unless the instrument is in the Keyboard Mode. The character "@" toggles the instrument, enabling and disabling the Error Mode. The cursor (intensified digit) can be moved to the left by programming "<" or to the right, by ">". The digit under the cursor is made more positive with the character ";" and made more negative with ":". The character "C" stores the NEW/REF CAL 1 OHM reference. Programming any instruction not legal for the Error Mode (Error Mode Codes, Standby or Operate) while in the Error Mode toggles the instrument out of the Error Mode. The Error Mode instructions do not require a terminator for action.

2-164. Recall

2-165. The instruction "G" (GET) places the instrument in the Recall Mode. When in the Recall Mode a legal instruction (G, +, -, V, A, H, D, M, T, L, ?) displays the stored data. Any instruction not legal for recall will toggle the instrument out of Recall, if it had been in that mode of operation. If a numeric is programmed while in the Recall

Mode an "Err1" results. Programming a terminator (.) prior to the numeric prevents the error message, as will a Clear (C), which also removes any error message inadvertently acquired. Programming Recall M (GM) or Recall followed by a function not selected, displays on the Central Display the magnitude of the function selected. The message must be followed by the Central Display Access Instruction (?) to place the data on an output device. The Recall instructions do not require a terminator for action.

2-166. Limits

2-167. The Entry Limit is programmed with the character "L" followed by the applicable magnitude entry. For example, the instruction L12.3456V would enter a limit of +/-12.3456V dc and any entry exceeding that figure would be rejected with an "Err3" display. The instruction "T" followed by the applicable magnitude entry sets the tolerance limits. The typical instruction T.05% would program a limit of 0.05% and any error exceeding that during Error Mode operation would illuminate the LIMIT indicator and flash the display, warning the operator the preset limits has been exceeded. Both limit entries may be set to their maximum figure, effectively disabling them, by entering the applicable instruction followed by the character "C" (LC or TC).

2-168. Wideband Option

2-169. When installed, the Wideband Option is enabled with the instruction "P1". It is disabled with the instruction "P0". When enabled the output is available at the dedicated connector and the applicable voltage and frequency specifications apply. A terminator is required for execution.

2-170. Boost Mode

2-171. The Boost Mode is programmed with the characters "B1". To obtain the output from the applicable amplifier (5205A/5215A for power or 5220A for current) program the desired output data followed, preceded, by the Boost Mode Command, and completed with a terminator. The output is on the terminals of the selected amplifier, and not on the calibrator output terminals. The Boost Mode is disabled with the instruction "B0". In both cases, enable and disable, the programmed instruction requires a terminator before it can be executed.

2-172. STORAGE COMMANDS
(STORAGE ONLY)

2-173. The Storage Commands are only used by instruments in the 5100 Series that are equipped with a Storage System and Tape Drive.

2-174. Storage Enable

2-175. The Storage Mode is enabled with the instruction "Q1" and disabled with "Q0". Until the Storage Mode is enabled with this instruction, the remaining storage commands are ignored.

2-176. Tape System

2-177. Enable the Tape Mode for a Read or Store operation on the tape with the instruction "I". Disable the Tape Mode with the instruction "O".

2-178. Store

2-179. Program the instruction "W1" to select the Store Mode and write data either in the storage memory or on tape. Select the Read Mode with the instruction "W0". This disables the store capability and permits the reading of data from either the storage memory or the tape system.

2-180. Advance/Load

2-181. The instruction "&" performs remotely the functions of the ADVANCE/LOAD switch. The actual function and performance varies with the state of the Tape, Read and Store Modes. With the Tape Mode disabled and the Read Mode selected, the program in the storage memory advances one step. Selecting the Store Mode with the Tape Mode remaining disabled results in the programming data being written into the storage location selected and then advancing the program one step. When the Tape Mode is selected the instruction starts the tape drive motor, which automatically advances until it reaches the end of the program.

2-182. Select/Display Step

2-183. The instruction "(" performs the same function as the Front Panel SEL₂ Display switch. The instruction, directly preceded by a numeric entry, displays the data in the program step corresponding to the numeric entry on the Central Display, after flashing the step number. The same instruction, without a directly preceding numeric entry, results in the flashing display on the Central Display of the current step number.

2-184. Delete Step

2-185. With the Store Mode selected the instruction ")" causes the program step presently selected to be deleted from the program. Insure the step counter is at the correct position before transmitting this instruction.

2-186. List Instruction

2-187. The instruction "K" lists the present program or the data for the current test as determined by the

Read Store Mode status. When the Store Mode (W1) is selected, the optional remote interface outputs to a printing device the stored program, starting with the program step selected. In the Read Mode (W0) a list data function results, with the data pertaining to the instruction on the instrument output transmitted through the optional remote interface to a printing device.

2-188. The transmission of any character, including carriage return and/or line feed, after the "K" terminates the output, deleting the listing. Any characters used by the system controller should be suppressed prior to transmission to assure an output of the listing.

2-189. Clear Storage Instruction

2-190. When the Store Mode has been selected the instruction "=" clears the program previously written in the storage memory.

2-191. DATA INSTRUCTIONS

2-192. The Data Instructions are required to select or change the output from the instrument. They set the polarity, magnitude, multiplier, and function of the 5100 Series output. The instructions required for each are listed in the following paragraphs.

2-193. Polarity Instructions

2-194. A positive or negative polarity can be entered with the characters "+" or "-", respectively. A positive polarity is assumed by the instrument if no polarity entry is made.

2-195. Magnitude Instructions

2-196. These instructions include the numeric characters "0" through "9", the decimal point "." and the slash "/" used for the fractional-scale divider.

2-197. Multiplier Instructions

2-198. The multiplier for the numeric value is entered into the string using the scientific notation method. The character "E" is programmed followed by the numeric value of the power of ten desired, i.e., for 10^2 program E2, 10^3 = E3, 10^4 = E4, etc. If there is no entry the instrument assumes units (10^0) for the instruction.

2-199. Function Instruction

2-200. The Function Commands define the output selected by the Magnitude Commands. The character "V" is programmed to select volts, "A" for amps, "Z" for ohms, "H" for Hertz, "D" for dBm, and "%" for percentage.

2-201. STATUS

2-202. Status Messages can with draw from the instrument and decode information in the status registers and the central display. The displayed data contains both alphabetic and numeric characters, unless the alphabetic characters have been suppressed using the applicable Interface Output Code. The Output Display is not directly accessible but may be placed on the Central Display with a recall instruction and then withdrawn with a status request. With any Status Message, all characters in the message must be accepted by the controlling device before any other operation can be performed by the instrument.

2-203. Status Register Message Instruction "!" or "?"

2-204. Entry of the characters "!" results in an immediate response of a nine-character message followed

by a carriage return and line feed to the interface. A terminator is not required for this control character. Characters 1 and 9 of the message are coded 0 through 9, and character 2 through 8 are coded 0 through 7. Since some functions or operations are mutually exclusive, not all code combinations are used in some characters. The characters, their position and the data provided are given in Table 2-17 and examples of status register messages are given in a subsequent paragraph titled PROGRAM EXAMPLES. When the indicated bit is true the data listed in the table is present, or selected. Conversely, in cases where two conditions are mutually exclusive (e.g., Operate and Standby, External Sense and Internal Sense, or Storage Mode and Read Mode) the false condition automatically selects the opposite of the listed condition. Bits 4 through 7 are always in the state indicated, which creates the ASCII number required for printing when joined with the variable four-low-order bits.

Table 2-17. Status Register Message Assignments

NO.	BITS 7-4	BIT 3	BIT 2	BIT 1	BIT 0	COMMENTS
1	0011	X	X	X	X	Decoded binary number corresponding to the Error Codes in Table 2-9. <i>NOTE</i> <i>Only error codes 4, 5, 6, 8, and 9 appear in character 1 of the Status Register Message. Actions that prompt the remaining codes clear themselves and therefore are transient. If an IEEE Interface is installed all error codes may be accessed using the SRQ line.</i>
2	0011	0	Ready	Overload	High Voltage	WARNING The High Voltage bit is set for a programmed voltage output above 20 Volts.
3	0011	0	Volts	Amps	Ohms	Only one function may be present at a time.
4	0011	0	dBm	AC	Operate	AC must be selected if dBm is present. Standby present if Operate is not selected.
5	0011	0	50Ω Override	50Ω Divider	External	50Ω Override and 50Ω Divider cannot be selected at the same time. Internal sense present if External Sense not selected.
6	0011	0	External Osc	Boost	Wideband	External Oscillator and Wideband cannot be selected at the same time.
7	0011	0	Recall	Error Mode	Keyboard	Recall and Error Mode cannot be selected at the same time.
8	0011	0	Storage Mode	Tape Mode	Storage System Enable	Applicable only to models with a storage system installed. Automatically zero for all other. Bit 0 must be true before either Bit 1 or Bit 2 can be enabled.
9	0011	X	X	X	X	Cursor position. Always 9 if Bit 1 of character 7 False. MSD digit position of Output Display is 0, increasing to 7 at second digit position of Central Display. In Error Mode 9 signifies off scale to left.

2-205. Central Display Access Instruction “?”

2-206. Entry of the character “?” results in the immediate response of a 5½ digit scientific notation number. The first digit will always be a 1 or 0 followed by a decimal point, five digits, “E” for exponent, the exponent sign, and the exponent digit. The sign of the exponent is transmitted only when it is negative. The sign for the number is transmitted only when it is relevant, i.e., it is not sent for AC amplitudes or frequencies.

2-207. The numeric message is followed by the character “L” if the LIMIT indicator on the Front Panel is illuminated. A character (Table 2-18) representing any illuminated function indicator on the Central Display follows the numeric portion of the message. When all data has been transmitted the message concludes with a Carriage Return and Line Feed.

Table 2-18. Status Message Function Codes

CHARACTER	INDICATOR ILLUMINATED
L	Limit
V	V – Volts
A	A – Amps
Z	Ω – Ohms
H	Hz – Hertz
D	dBm – Decibal Milliwatts
%	% ERROR
G	dB ERROR

2-208. Only the data on the Central Display is transmitted with the character “?”; however, the data can be frequency from an AC operation, a percentage during Error Mode operations or any data available on the Central Display during Recall operations. Examples of each of the above are given in the following paragraphs.

2-209. When the instrument is operating in the AC Mode the frequency selected is displayed on the Central Display. If this frequency was 400 Hz and the Central Display was requested with the character “?”, the response would be 0.40000E3H CR LF. A frequency of 10 kHz would be transmitted as 1.00000E4H CR LF. Any other frequency would result in status message in the same format.

2-210. In the Error Mode, the frequency for editing, the percentage of error calculated, and the dB error calculated can be transmitted in a status message when they are present on the Central Display. If the message is a percentage of error or dB figure and it exceeds the preset tolerance limits so that the LIMIT indicator is illuminated, the message ends with the character “L”.

2-211. A frequency transmission is transmitted as described above.

2-212. A percentage error is transmitted as shown on the Central Display, i.e., a reading of 0.0031 would be transmitted as 0.0031E0% CR LF.

2-213. In the Recall Mode, any data that can be recalled to the Central Display can be transmitted in the status message. This includes programmed values for volts, amps, ohms, dBm, the voltage when dBm is programmed, the tolerance limits and the entry limits, both voltage and current.

2-214. Recalled programmed entry limits of +750V dc would be transmitted as +0.75000E3VL CR LF.

2-215. An output of +150 μA dc recalled and transmitted would be +1.50000E-04A CR LF.

2-216. Program Examples

2-217. The following paragraphs contain several programming examples to aid the operator in using the calibrator.

2-218. Use the following instructions to obtain the output listed:

1. +6E-3A, N-In operate with an output of +6mA dc.
2. 5V1E3H, N-In operate with an output of 5V ac at 1 kHz.
3. L+300VL-250V - Set the entry limits at +1300V dc and -250V dc.
4. <T.01% - Sets the tolerance limit to ±0.01%.
5. 1.5VX1R1, N-In operate with an output of +1.5V dc and the instrument prepared for four-terminal sensing with the 50 ohm divider overridden.
6. GL+V? - Recall the positive voltage entry limit and output it in a Central Display Access Word.

2-219. Some typical status register messages and their decoded explanation are given in Table 2-19.

Table 2-19. Status Message Examples

1. 004210019	No. 1 = 0 = 0000 = No errors
	No. 2 = 0 = 0000 = None selected
	No. 3 = 4 = 0100 = Volts selected
	No. 4 = 2 = 0010 = AC and Standby selected
	No. 5 = 1 = 0001 = External Sensing selected
	No. 6 = 0 = 0000 = None selected
	No. 7 = 0 = 0000 = None selected
	No. 8 = 1 = 0001 = Storage system enabled and Read Mode (default)
	No. 9 = 9 = 1001 = Error Mode not selected
2. 61410109	No. 1 = 6 = 0110 = Module missing (error code 6)
	No. 2 = 1 = 0001 = High voltage dc programmed
	No. 3 = 4 = 0100 = Voltage selected
	No. 4 = 0 = 0000 = DC and standby selected
	No. 5 = 1 = 0001 = External sensing selected
	No. 6 = 0 = 0000 = None selected
	No. 7 = 1 = 0001 = Keyboard Mode selected
	No. 8 = 0 = 0000 = Storage system not selected
	No. 9 = 9 = 1001 = Error Mode not selected
3. 001100275	No. 1 = 0 = 0000 = No errors
	No. 2 = 0 = 0000 = None selected
	No. 3 = 1 = 0001 = Ohms selected
	No. 4 = 1 = 0001 = Operate selected
	No. 5 = 0 = 0000 = Internal sensing selected
	No. 6 = 0 = 0000 = None selected
	No. 7 = 2 = 0010 = Error Mode selected
	No. 8 = 7 = 0111 = Storage system enabled, Store Mode & Tape Mode
	No. 9 = 5 = 0101 = Cursor on LSD of output display



Section 3

Theory of Operation

3-1. INTRODUCTION

3-2. The 5100 Series B Calibrators are a controllable source of AC and DC voltage, AC and DC current, and a set of precision resistors. The control of the voltage and current magnitude is provided by an analog control system. A Digital Controller responding to either Front Panel or remote digital commands chooses the desired output (i.e., AC volts, DC current, etc.), sets the desired magnitude and operates the front panel displays.

3-3. Explanations at an instrument block diagram, functional block diagram, and detailed circuit analysis level are contained in the following paragraphs. The functional block diagram section is divided according to the function performed, i.e., DC voltage, AC current, etc., followed by the Digital Controller System, the detailed circuit analysis deals with the individual pcb assemblies.

3-4. INSTRUMENT BLOCK DIAGRAM

3-5. The block diagram of the 5100 Series B in Figure 3-1 shows the major function of the instrument. An explanation of the operation is given in these paragraphs followed in subsequent paragraphs by an explanation and block of each operating function within the instrument.

3-6. The Digital Controller receives all commands to the calibrator via the Front Panel from an operator or from a remote location by either the IEEE-488-1975 (Option -05) or RS-232-C (Option -06) Interface Assembly. The Digital Controller in turn transmits digital signals to a DAC (digital-to-analog converter), block A in Figure 3-1, relays and FET switches in block B, relays and FET switches in block C, and the Front Panel indicators in block D. The commands received by the Digital Controller are displayed thereon as well as Error Messages in the event of an out-of-range or incorrect command, and other status indications.

3-7. The analog control system senses the output voltage or current, by using precision voltage dividers, current shunts, and AC converter, as is appropriate, block B, Figure 3-1, and presents the resulting DC voltage to one input of a precision Integrator-Comparator, block E.

3-8. The other input is supplied with a precision voltage from the DAC, proportional to the desired voltage or current output of the calibrator. Any difference between the two inputs is amplified by the Integrator-Comparator to produce a controlling signal for the controllable source. The Integrator-Comparator also provides the phase and frequency compensation that establishes the control-loop time response.

3-9. FUNCTIONAL BLOCK DIAGRAM

3-10. DC Voltage Less Than 20 Volts

3-11. There are three power amplifiers on the Power Amplifier Assembly to provide the output voltage and current levels needed at the output terminals in the DC Voltage and other modes. The isolation circuitry in the Current Modes is also contained on the assembly. Figure 3-2 is a simplified diagram for 0 to $\pm 19.9999V$ DC. The High Frequency Amplifier, A1, drives the output high terminal directly. The high sense terminal feeds this voltage to the voltage ranging resistors and switches where it is divided by two before being applied to the Integrator-Comparator for comparison to a precision voltage supplied by the DAC. The DAC is programmed via the Digital Bus to produce one-half of the desired calibrator output voltage with the desired polarity. When there is a difference between the DAC voltage and that from the voltage ranging, the integrator produces a voltage, "Control", that drives the input to A1 so as to correct the calibrator output.

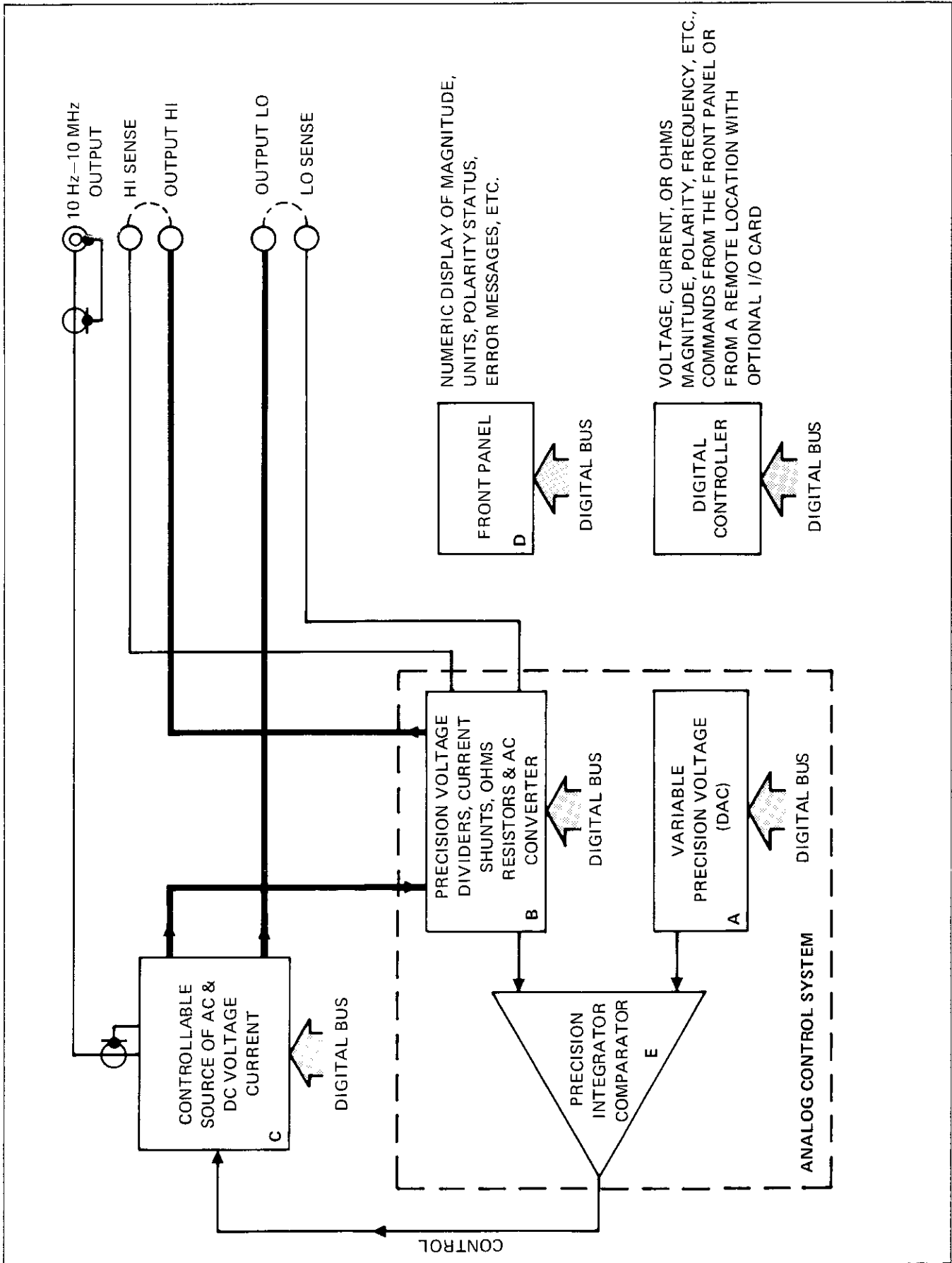

Figure 3-1. 5100B Block Diagram

3-12. Figure 3-3, illustrates the 2 volt, 200 millivolt, and 20 millivolt DC ranges, 0 to 1.99999V dc. The only differences are the addition of the Millivolt Divider between the A1 output and the output high terminal and a change in the voltage ranging connection to the top of the Millivolt Divider. This gives better accuracy and lower noise when calibrating meters at low voltages than using the Integrator and DAC directly. It is possible to bypass the Millivolt Divider if its 50 ohm output resistance makes it undesirable in a particular application. The "50Ω DIVIDER OVERRIDE" function will hold the calibrator in the 20V dc range even though low voltages are called. Front panel lights indicate when the calibrator output is from the Millivolt Divider or if it is in the OVERRIDE mode.

3-13. AC Voltage

3-14. An oscillator generates a fixed, low-distortion sine wave for all AC outputs. It is a phase-shift oscillator circuit which consists of two cascade integrators and an inverter. The amplitude is held at approximately 1.2V rms by a self-contained amplitude control system that is independent of the main system. Figure 3-4 shows the configuration for the 20V ac range. Note the differences from the diagram in Figure 3-2. The A1 is now supplied an AC signal from the oscillator through a photoresistor, U103. The resistance of U103 is set by the light from its LED. The LED current, in turn, is set by the Integrator output voltage, "Control". The voltage ranging now divides the output by 10 and drives an AC Converter through an AC Buffer before being applied to the Integrator. The AC Buffer has unity gain and isolates the AC Converter's relatively low input impedance from the voltage ranging circuit. Notice that the DAC output is now +2V for 20V ac output and that its minimum voltage is 0.2V instead of zero as in Figure 3-2. The AC Converter operates best at voltages from 0.2 to 2.0 volts.

3-15. Figure 3-4 also shows the transformer, T2, that is used to obtain 20 to 110V from 1 kHz to the specified maximum frequency of 20 kHz for this range. The voltage ranging now divides by 100.

3-16. For AC voltages below 2V, the output from the A1 is reduced by the Millivolt Divider in the same manner as for lower DC volts, Figure 3-3. The AC Buffer is connected to the 2V tap on the Millivolt Divider instead of to the top end as is done in the case of DC volts.

3-17. AC and DC Voltage, 20 Volts & Higher

3-18. The block diagram for AC and DC voltages of 20V through 1100V and below 1 kHz is in Figure 3-5. The High Frequency Amplifier, A1, drives a higher power

amplifier, A2, (Low Frequency Amplifier) which in turn drives step-up transformer, T1. The High Frequency Amplifier receives a controlled input from the oscillator through U103, as described above. The integrator, DAC, etc., have been omitted because they are connected in the same way as shown in Figure 3-4. The connections shown in Figure 3-5, are for the 20 to 250V ac output. Amplifier A2 supplies approximately 2.8 to 35V ac to a tap on the primary of T1, the low frequency output transformer. For an output of 20 to 1100V dc, rectifiers and active filters are switched in between the transformer and the output terminals. Also, the oscillator is set to 1 kHz and its waveform is modified to minimize the peak currents that A2 must supply to the transformer, T1.

3-19. AC Current Under 200 mA

3-20. Figure 3-6 is the block diagram illustrating the AC Current Mode below 200 mA. The current ranging resistors (current shunts) are switched for each 10 to 1 change in output current magnitude. This maintains an input voltage between 0.2 and 2 volts to the AC Buffer as in the AC Voltage Mode described above. Notice an important difference. In AC volts, Figure 3-4, the common for the DAC, AC Buffer, etc., ∇ F, was connected to LO sense and output LO which is the common for A1, oscillator, etc. In the AC Current Mode, the ∇ F common is connected to the A2 end of the current ranging. It is a "floating" ground. All circuits, including power supplies, that are connected to this common are floating and shielded. A transformer and optical-isolators in the DAC transfer Digital Bus signals to the ∇ F common. Photoresistor U103 isolates the output of the integrator, "Control", from the input of A1. Without this isolation, the input to A1 would vary, not only with the "Control", but also with the calibrator output voltage (compliance voltage).

3-21. There is an additional amplifier used in the Current Modes: the Current-Guard Driver. It is a non-inverting, unity gain operation amplifier that drives the I-Guard terminal on the panel and shields placed around the current ranging resistors. In this way, stray capacity for output high to output low (common ground $\frac{1}{2}$ and $\frac{1}{2}$) is isolated and driven by the I-Guard Driver. If it were not, the capacity would be driven by A2 with the resulting current flowing through the current ranging resistors. Since this is in addition to the actual calibrator output current, it would cause an error, especially at the higher frequencies and lower currents. The I-Guard terminal permits the user to extend this guard to enclose the lead from the output high terminal to the meter under test. The operation above 200 mA is explained in the following paragraph.

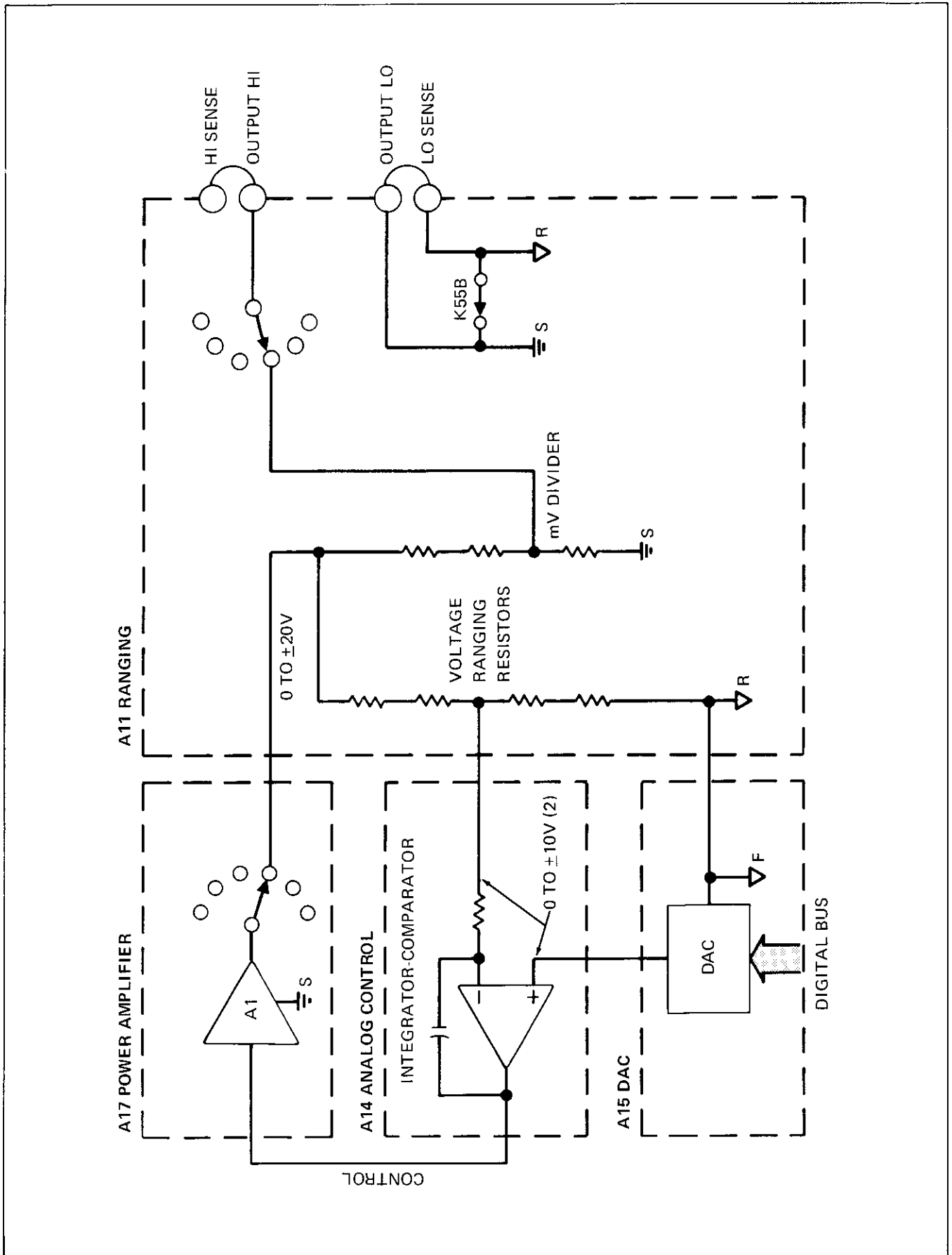

Figure 3-3. Less than 2V dc Outputs Block Diagram

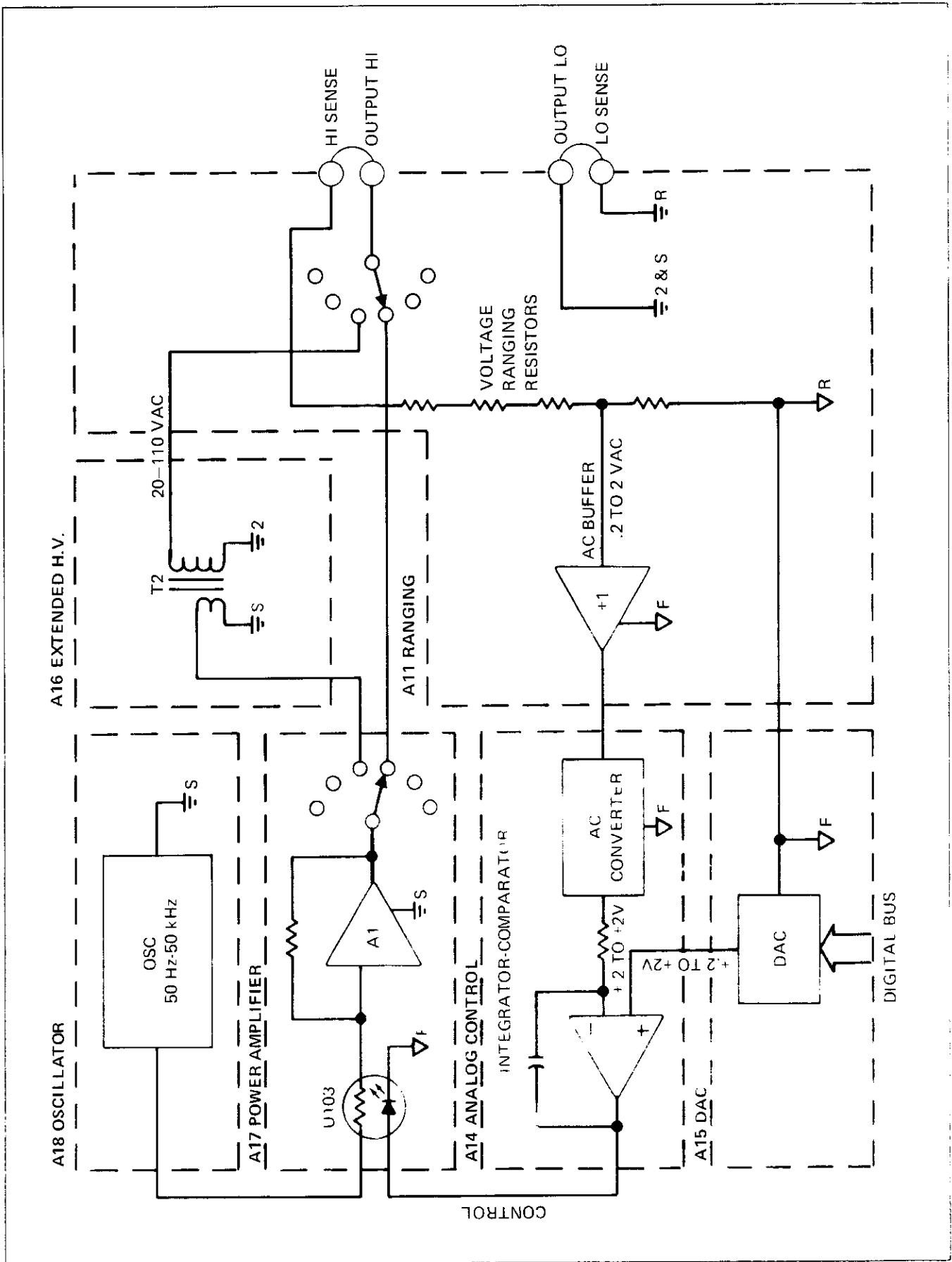

Figure 3-4. AC Voltage Block Diagram

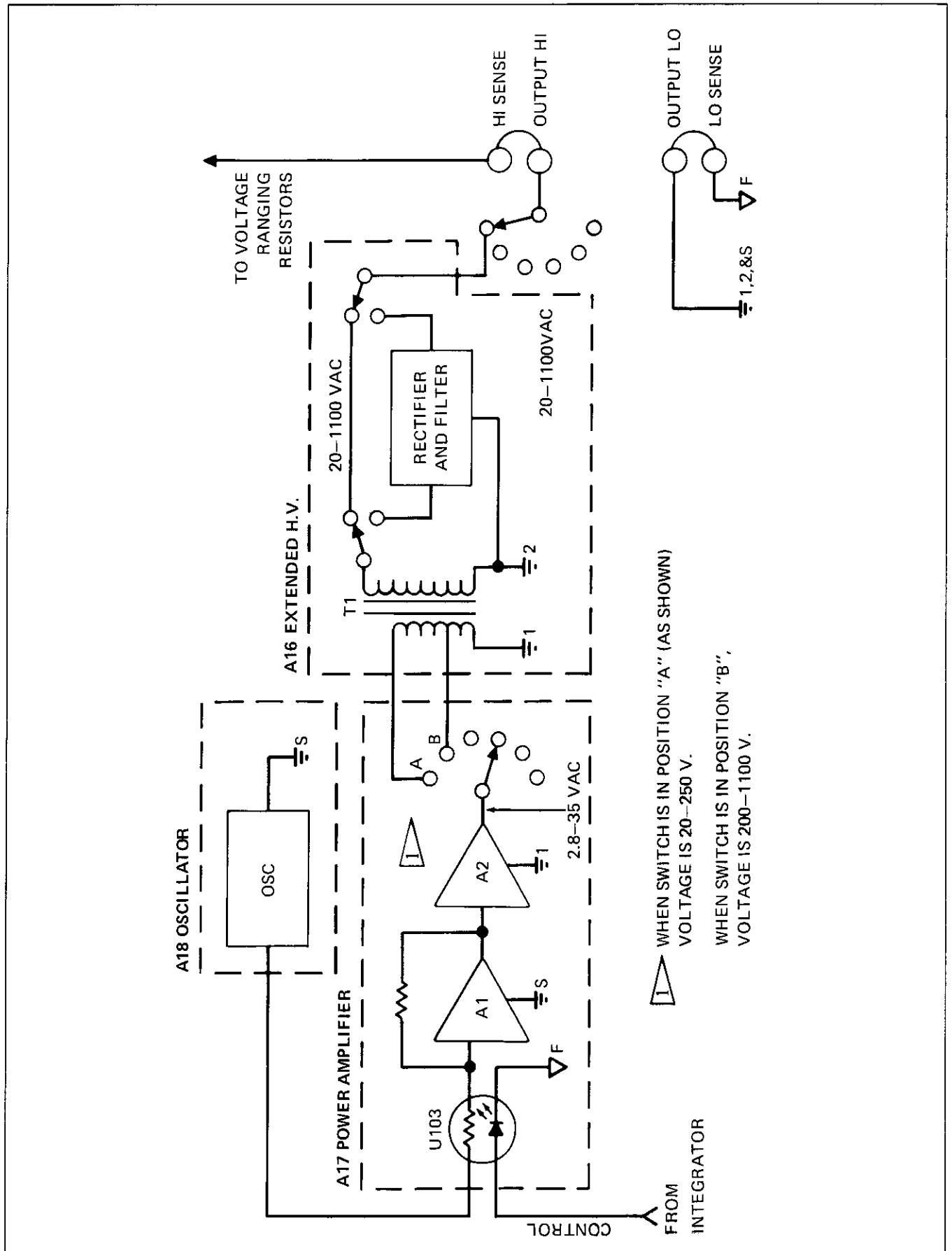

Figure 3-5. AC and DC Voltage, 20V and Higher

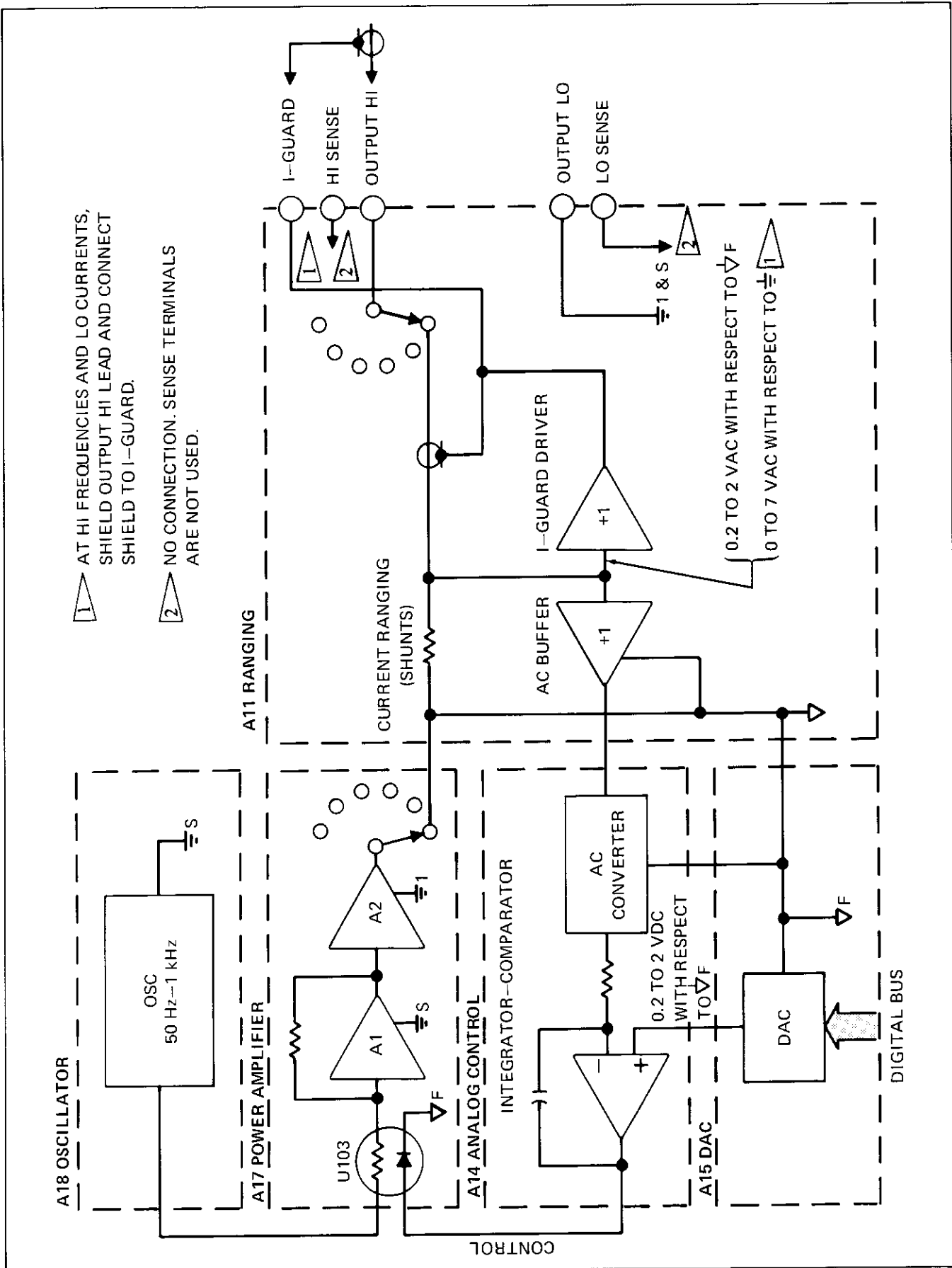

Figure 3-6. AC Current Under 200 mA

3-22. DC Current Under 200 mA

3-23. The Direct Current Mode under 200 mA is similar to the AC Mode. See Figure 3-7. The ∇ F common "floats", the same current ranging resistors are used, etc., but the isolation between the integrator output ("Control") and the AI input is different. In place of U103 are U108 and U109. The "Control" voltage drives the LED in U108 or U109 through amplifiers (omitted for clarity). When U108 is driven, varying positive current is supplied to AI. When U109 is driven, the current to AI is negative. Thus, the input to AI amplifier is proportional only to the "Control" voltage as in the case of ac current above; but, in this case, the input is dc.

3-24. Direct and Alternating Current >200 mA

3-25. For Alternating or direct currents above 200 mA a third, high current, low voltage amplifier, the High Current Amplifier, is used in place of A2 shown in Figures 3-6 and 3-7. Otherwise, there is no difference.

3-26. Resistance

3-27. Figure 3-8 and 3-9 show the connections in simplified form for Low and High Ohms Mode. Four-terminal (EXT Sense) and two-terminal (INT Sense) connection is provided for values of 10,000 ohms and lower. Notice that all the resistors, except one, have dual usage: 1 ohm through 10 kilohms are also used for current ranging and 100 kilohms and 1 Megohm are used for voltage ranging. This saves space, cost, and calibration time since two separate sets of precision resistors are not needed.

3-28. Control System

3-29. The internal control of all aspects of the calibrator is centered in a Digital Controller (Figure 3-10). It is connected to all of the pcb modules (except the power supply) by the Internal Digital Bus. Each pcb has one or more addresses. The Controller directs commands to specific pcbs or section of pcbs by preceding each command with the appropriate address. Each module transmits an acknowledge signal to the Controller after receipt of the command data. In addition, some modules transmit data to the Controller.

3-30. CONTROLLER

3-31. The Controller (Figure 3-11) is a small, specially programmed digital computer, consisting of: a microprocessor (μ P) with timing, interface, and logic that

constitutes a Central Processing Unit (CPU); Read Only Memory (ROM), and Random Access (Read/Write) Memory (RAM); and buffers to interface the controller to the Internal Digital Bus. All control is by solid-state switches and mechanical relays optimally located on pcbs throughout the calibrator. They respond to commands from the Controller. Commands to the Controller, in turn, originate from an operator using the Front Panel or from an external (remote) source via the IEEE-488-1975 or RS-232-C Bit-Serial Interfaces. The Controller also transmits to the displays on the Front Panel the commands it has received and error messages.

3-32. FRONT PANEL

3-33. The operator controls and monitors the calibrator operation from the Front Panel. Voltage, frequency, etc., are entered via a keyboard, similar to an electronic calculator, or via rotary switch. As each key is depressed, the Controller, which periodically scans all keys and the rotary switch positions, decodes its function through the use of the μ P and data stored in the ROM, places the result in the RAM, and lights the appropriate Front Panel indicator in the Central Display. When a complete group of numbers, units, and/or a function has been entered, the operator presses the ENTER key. The Controller now checks to determine if the group is a valid entry by comparing it to data stored in the ROM. If invalid, an Error Message is displayed on the panel and no further action takes place. If valid, the group is manipulated and encoded for transmission via the Internal Digital Bus to the appropriate analog pcb modules and on the Front Panel the display is shifted from the central to the output display on the left side.

3-34. INPUT/OUTPUT

3-35. This module operates with the Controller through the use of a handler program stored in the ROM. It interfaces the Internal Digital Bus (which is optimum for internal data handling and is common to other Fluke instruments) to the IEEE-488-1975 or RS-232-C Interface. Details on the respective I/O options are found in the applicable portion of Section 6.

3-36. GUARD ISOLATOR

3-37. This module transmits data both ways between the unguarded and guarded sections of the calibrator while maintaining the required isolation.

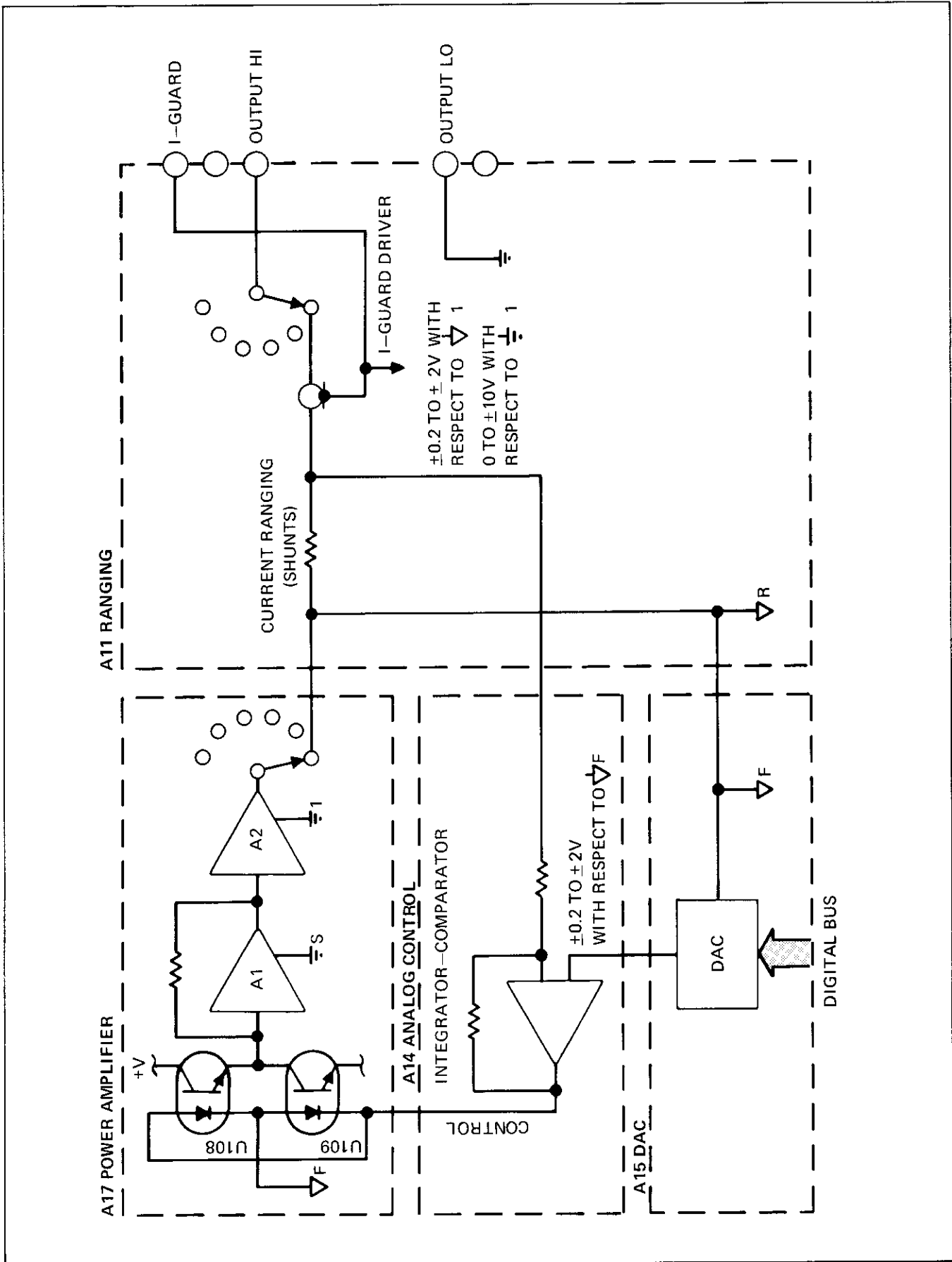

Figure 3-7. DC Current Under 200 mA

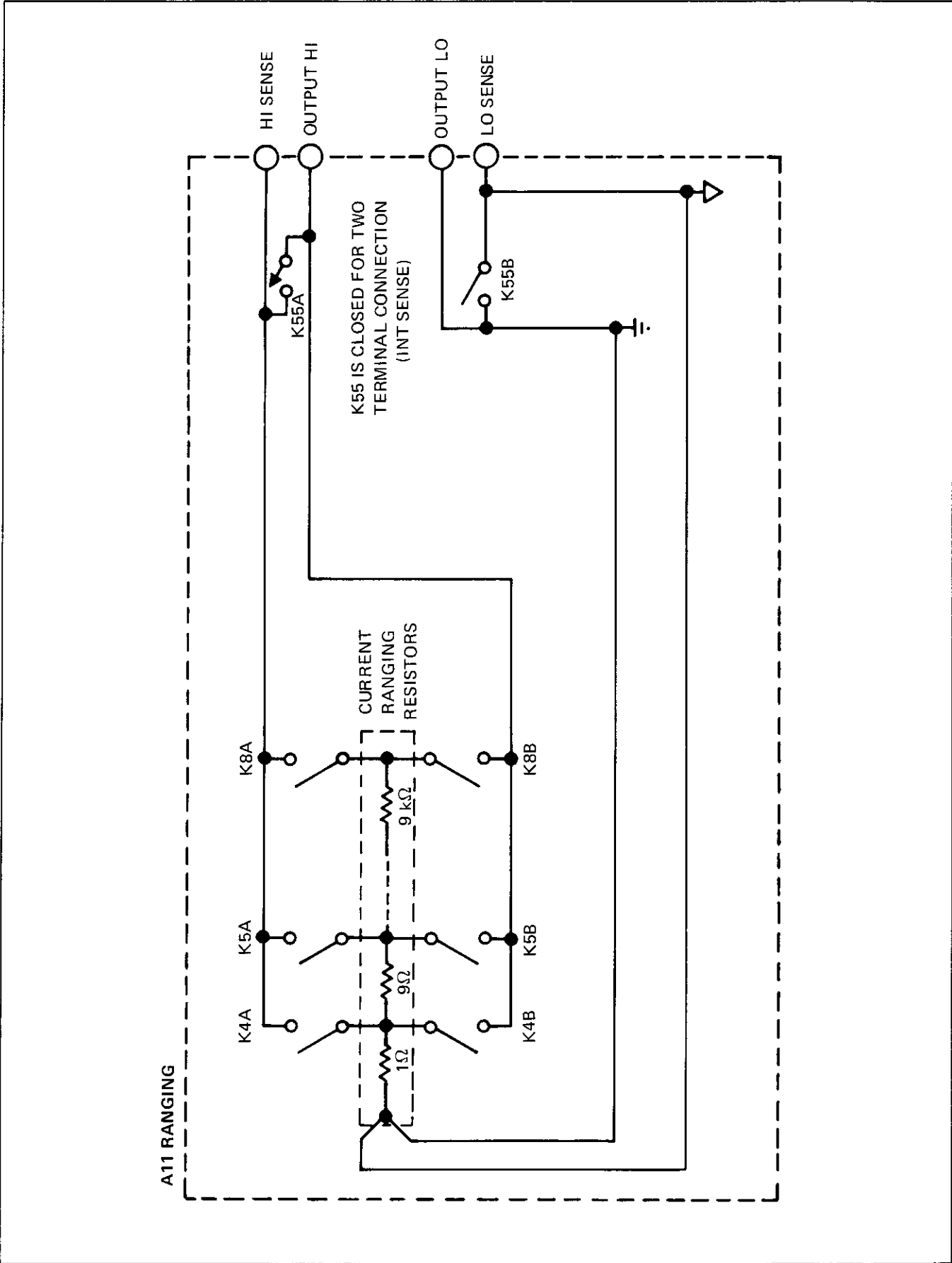

Figure 3-8. 1Ω - $10\text{ k}\Omega$ Resistance

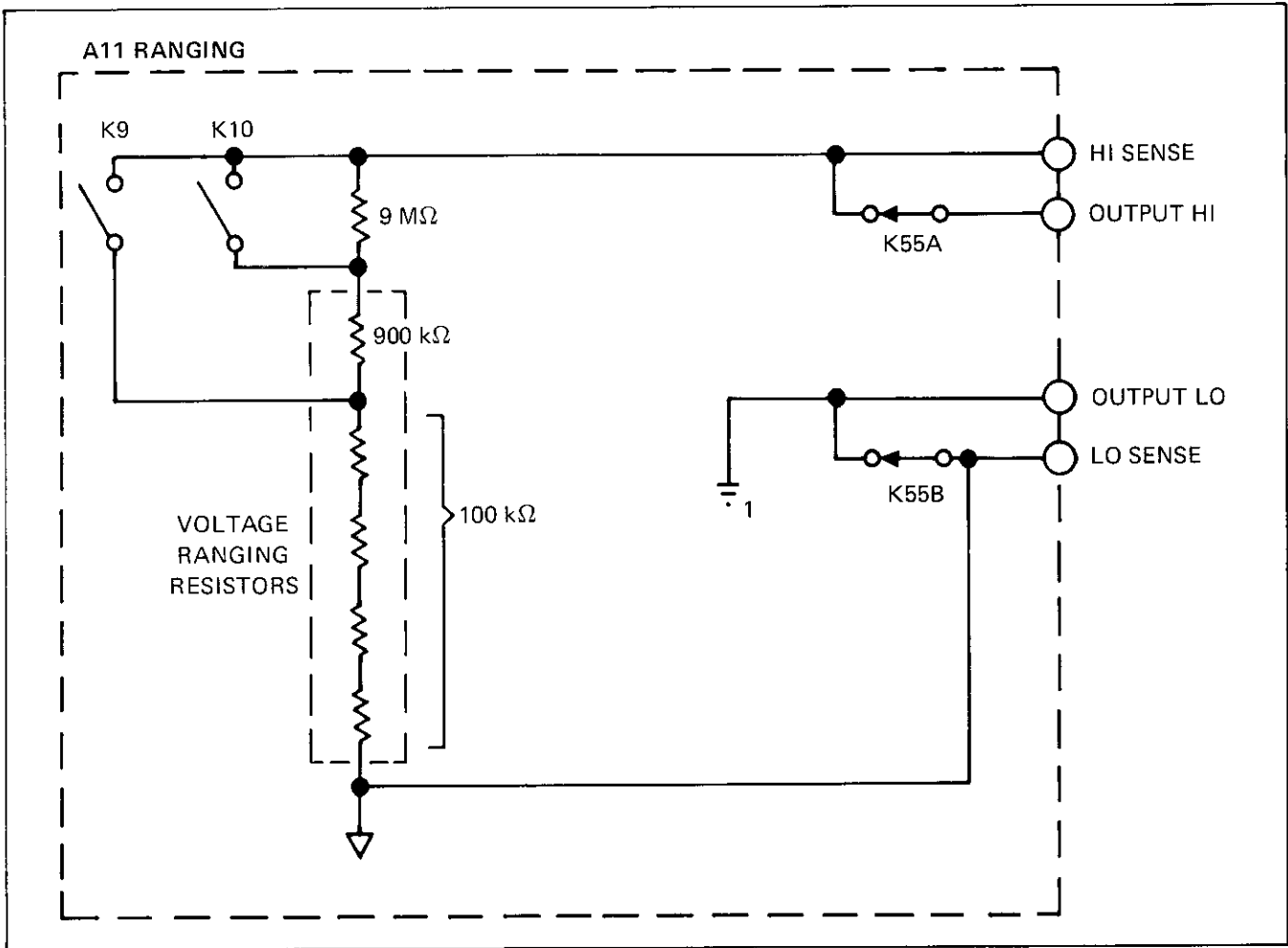

Figure 3-9. 100 kΩ - 10 MΩ Resistance

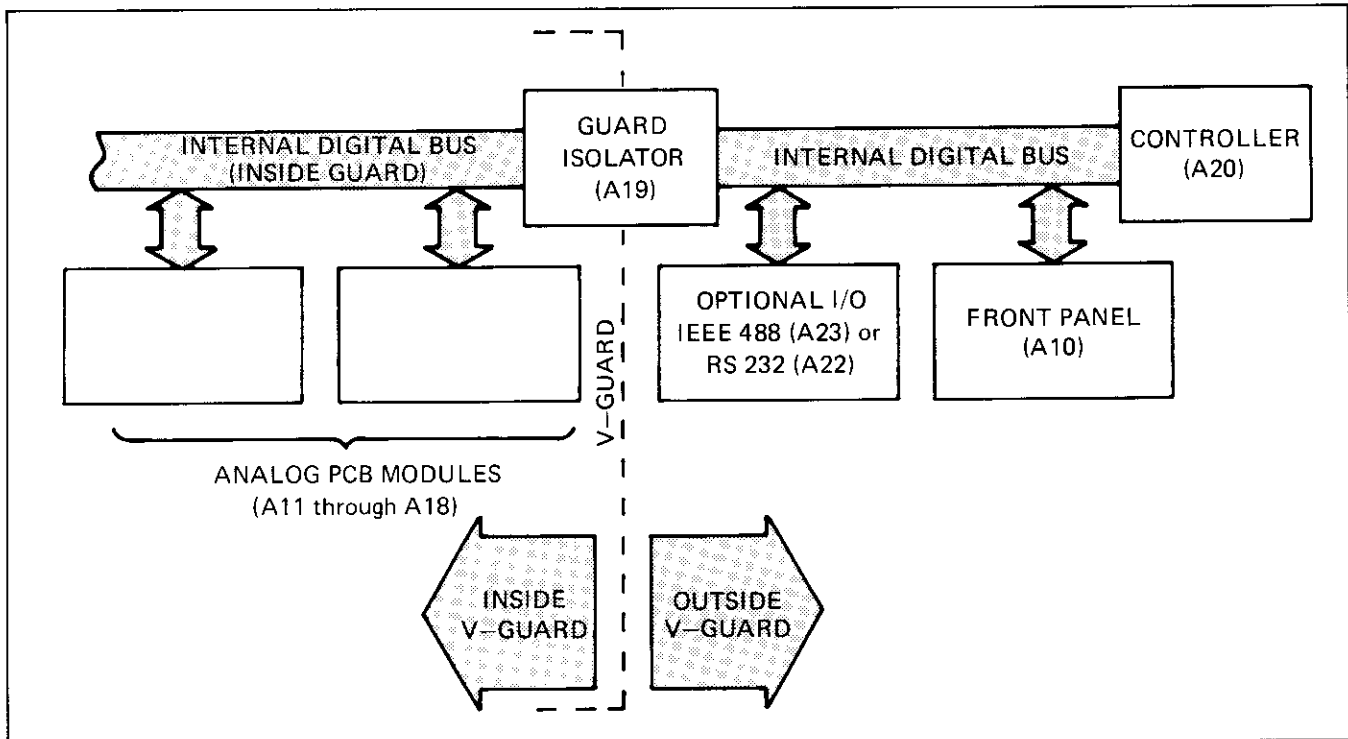

Figure 3-10. Control System Block Diagram

3-38. DETAILED CIRCUIT ANALYSIS

3-39. The following paragraphs contain a detailed circuit analysis of the individual pcb assemblies. Consult the schematic drawings in Section 8 when components are referred during the discussion.

3-40. Power Supply Regulator

3-41. The Power Supply Regulator supplies the calibrator with guarded, unguarded, and floating voltage outputs, in addition to a real time clock (approximately 60 Hz) and a power on preset generator.

3-42. UNGUARDED SUPPLIES

3-43. The three DC outputs from the unguarded supplies are +5 volts, +12 volts, and -12 volts. The +5V supply is regulated by U3 with transistors Q1 and Q22 to increase the output current capacity. Current is limited by R3 and R77 to approximately 4.5A. The triac, Q19, provides overvoltage protection. If the output exceeds 5.6 volts, VR1 conducts, firing Q19, clamping the input voltage to less than 1 volt, and opening the fuse, F1. The output voltage can be adjusted, over a limited range, underload with the variable resistor, R93. The +12V and -12V supplies are controlled by the fixed voltage, three-terminal regulators, U1 and U2, respectively.

3-44. FLOATING SUPPLIES

3-45. The floating supplies provide regulated +5 volts, +15 volts, and -15 volts from unregulated inputs of +5 volts and ± 40 volts. The ± 40 volts, which is required elsewhere in the instrument, is dropped to manageable levels by the zeners, VR12 and VR13, for +15V regulator, U6. The +5V supply is regulated by the three-terminal regulator U4.

3-46. GUARDED SUPPLIES

3-47. Outputs of +15V, -15V, +62V, -62V, +39V, -39V, and -20V are obtained from the guarded supplies. The +15V is obtained from the regulator U7, augmented by the series pass transistor Q2. Output current is sensed by R4 and R85 for overload limiting. The supply is adjusted with the variable resistor R6.

3-48. The +15V is used as a reference for the remaining outputs of the guarded supplies, either directly, indirectly through the -15V supply, or both. The divider, R9 and R10, and the operation amplifier, U8, detect any difference between the plus and minus 15V supplies to drive the series pass transistor Q3 and reduce the difference to near zero. Resistors R12 and R86 sample the output current and, if it exceeds 0.6 volts, Q4 conducts to reduce the base current of Q3 and reduce output current.

Q21, CR16, CR17, CR18, and R74 provide a constant current sink to the base of Q3 and the output of U8. The zener VR2 provides voltage translation from the base of Q3, at -15.6 volts to the output of the op-amp or near zero volts.

3-49. The -20 volt supply provides the +5 volt logic supply by connecting the high side of the -20 volt supply to the regulated -15 volt supply so the low side, logic common, is at -20 volts with respect to the grounds ($\frac{+}{-}$ and 1). The supply is regulated by U11 with transistors Q15 and Q23 to increase the output current capacity. Current is limited by R31 and R73 to approximately 4.5A. The triac, Q20, provides overvoltage protection. If the output exceeds 5.6 volts, VR11 conducts, firing Q20, clamping the input voltage to less than 1 volt, and opening the fuse, F1. The output voltage can be adjusted over a limited range, under load, with the variable resistor, R84.

3-50. The plus and minus 62 volt supplies operate essentially the same as the -15 volt supply with the exception of component values. The +15 volt supply provides a reference for the +62 volt supply and the -15 volt supply to the -62 volt supply. The 30 volt zeners, VR5 and VR6, are used to regulate the input voltages to the proper level for the operational amplifiers. The ± 62 volt supplies are further regulated to provide ± 39 volt supplies. The regulating circuitry is essentially the same as the ± 62 volt and -15 volt regulators. The ± 15 volt supplies are used as the references.

3-51. REAL TIME CLOCK

3-52. The real time clock generator provides a square wave output at approximately 60 Hz to synchronize timing functions in the Controller. The frequency is derived from U16 which operates as a free-running multivibrator with the frequency set by the values of R80 and C62.

3-53. POWER ON PRESET GENERATOR

3-54. The Power On Preset (POP) Generator provides a low-going pulse (POP) upon the application of power to the instrument. The pulse provides a clear signal to the logic, preventing the latches from turning on relays, switches, etc., in a random manner, possibly resulting in damage to the equipment or operator.

3-55. Digital-to-Analog Converter (DAC)

3-56. The DAC consists of digital and analog sections, each individually guarded, that are optically coupled. The digital section consists of a clock, two counters, one an increment by ten-to-two hundred thousand and the other an increment by one-to-ten, latches to hold the preset

data, and addressing circuitry. The analog section converts the digital output into a square wave with the duty cycle representing the output voltage. Each of the sections is described in greater detail below.

3-57. DIGITAL SECTION

3-58. The +5V logic signal for the digital section is derived by using the -15V for the logic high and -20V as common. This procedure is common with the guarded portion of the instrument. The high negative levels are required to turn off FETs in the analog circuitry.

3-59. The programmed output value is loaded into five quad latches (U26, U6, U11, U14, U20) and a single latch for the overrange digit (U15). The data entered is compared with two separate free-running counters, a major counter (U4, U9, U12, U18, and U17-3) which increments by tens up to two hundred thousand, and minor counter (U24) which increments by one up to ten. Both counters automatically reset to zero and restart when the maximum count is reached. The major counter is clocked by the 4 MHz clock at U17-5, which is a divide-by-two circuit for the 8 MHz output of the free-running clock formed by Y1 and its associated components. The programmed data is clocked into the latches from the data lines (ID0 through ID7) on commands decoded from the control lines (IC0 through IC4).

3-60. The programmed output two MSD digits are clocked into U15-8 and U20 when the first address is decoded at U8-9. In addition, a preset signal at U15-4 sets U15-5 high to enable the second and last address gates. The second address gate at U8-6 loads the third and fourth MSD digits at U14 and U11, respectively, and the fifth MSD and LSD are loaded into U6 and U26, respectively, with the last address at U8-10. The last address also clocks U15-3 for a low at U15-5, disabling the second and last address gates.

3-61. When the programmed data and both counters contain the same count, the latches \bar{Q} are set high (U29-10 for the major counter and U29-14 for the minor) to control the duty cycle, and through it, the analog output. The comparator (U5, U10, U13, U19, U25) compares each \bar{Q} output from the counters against the equivalent Q of the data latches with an exclusive OR circuit and the output of the comparator is wire ORed to set the U29 latches.

3-62. The number actually stored in the latches for comparison with the major and minor counters is one digit less than the figure keyed in at the Front Panel. For example, if 19999 is keyed in on the Front Panel (the DAC scales the figure, ignoring decimal placement), the latches corresponding to the major counter would be

loaded with 19998 by the microprocessor and the latch matching the minor counter would be loaded with 8. The same holds true for zero. Loaded would be 19999 and 9 for the major and minor counters, respectively.

3-63. Since the major counter MSD only requires one of the four bits available on the data lines, the first address loads the remaining three bits into U35 to operate relays which control the analog circuitry.

3-64. ANALOG SECTION

3-65. The analog section takes the square wave created by the digital section and outputs a percentage of the full-scale value available as determined by the duty cycle of the waveform. For example, if the programmed count was at 50,000 the duty cycle would be 25% of the total count and the output would be 25% of the available full-scale output.

3-66. The clock is transferred across the guard to the analog circuitry for use on U34 with pulse transformer T1. The signal at U34 is synchronous but is one clock behind due to the transferring action. The remaining data is transferred using opto-couplers. The output from the the matching counters and latches is transferred to U34, summed, filtered, and output from the DAC in ranges of either zero to 10 volts or zero to 2 volts, as determined by the status of relay K3 and U35-15. The major cycle uses the output at U34-5 and -6 to operate the common base drivers, Q10 and Q11, which in turn drive the FETs, Q2 and Q4, which are fast-switching devices with precise known resistance. The output is filtered at U39, and with the bootstrap capacitor C11 (which is completed by the follower amplifier on the Analog Control PCB). The two values are summed and divided by R35 in parallel with the series resistors R36, R37, R42, and R40, to give an output between zero and 10 volts, proportional to the duty cycle. For DC current and AC measurements, K3 is energized, and Q6 through Q9 enabled to change the network by inserting R38 and R41 to VR CIM into the circuit of an output between zero and two volts, proportional to the input duty cycle. The input to these dividers comes from the regulator on the Analog Control PCB as either +VR (+10.0005V dc) or -VR (-10.00004V dc) as determined by the status of K1 and K2.

3-67. The analog section uses a floating 5V supply for part of the circuit. These are identified as +5V (FH) for floating high and +5V (FC) for floating common. Floating common is tied to either -15V for +VR switching or the output of U33, which is approximately -24V for -VR switching, as determined by the status of K1 (energized with +VR selected) and K2 (-VR selected). The lower common is required to turn off the FETs in the applicable circuit because the switching voltage could exceed the breakdown voltage to the FETs if left at -24V when +VR is switched.

3-68. Analog Control

3-69. The Analog Control PCB Assembly has four individual sections. Included are the reference voltage circuit, which provides the plus and minus 10 volt references from the reference amplifier and inverter. The main DC amplifier, or integrator, where the input is compared to the reference and the difference amplified to generate an error signal for the power amp to use to zero the error. The AC Converter is an averaging converter and full-wave rectifier, and the control section, with the compliance voltage limiter and detector.

3-70. REFERENCE VOLTAGE SECTION

3-71. The reference voltage section is based on the action of the accurate and stable reference amplifier U10. Low frequency ripple is removed with the circuit formed by U2, Q2, and their associated components, and high frequency ripple with Q1, Q16, and their associated components. Output spikes are removed by C9, and C22 is for spike suppression. To reduce errors the circuit common (VR COM) is independent, and connected to the floating ground on the DAC.

3-72. Negative output is obtained by using a unity gain inverter, op amp U3. Q10 and CR2 are installed in the circuit to prevent it from stabilizing at some voltage other than -10V. Without them it would be possible for the circuit to stabilize at 0.6V.

3-73. The ref amp circuit has several components that require special selection. U10, R9, and R10 are selected as a set after TC checks. They must always be replaced as a set. R17 and R20 are also matched for TC and must be replaced as a set. R13 and R14 are selected from values determined with a decade box using the procedure found later in this manual.

3-74. INTEGRATOR

3-75. The DAC output is integrated with the selected of three feedback paths. The feedback input is through Q73 when input for the dc attenuator, through Q74 when from the AC Converter, or through K3B when from an external source, e.g., the Wideband Option. An op amp is formed by Q65, Q68, U67, and their associated components with the DAC output at P53 to the non-inverting input and the feedback signal supplying the other op amp input. U61 and its associated components provide the bootstrap circuit for the signal from the DAC output at P37-51. The output of U61 also goes to the zeners VR60 (3.9V) and VR61 (6.2V) for 1 mA current flow through the diodes, CR60 and CR61. The maximum signal applied will be limited to 13 volts due to the back-to-back zeners VR62 and VR63. Q62, Q63, Q69, and

CR70 provide additional protection by clamping the bases of Q68. R71 (DC BIAS) is adjusted for zero drift, with TP13 and TP14 shorted, to balance the input to the integrator.

3-76. The resistors R65 and R67 are a matched pair and must be replaced as such. R64 and R66 are selected to go with the op amp formed by the Q65, Q68, U67 combination. One will be a selected value and the other replaced with a piece of bus wire. Refer to the procedure later in the manual when reselection is required due to replacement of the installed resistor or one of the op amp components, Q65, Q68, or U67.

3-77. AC CONVERTER

3-78. Buffered AC is input at P51-21, routed through R32 and R36 to the op amp made up of Q36, U37, and the output stage Q45, Q46. The high impedance output goes to the two feedback diodes CR46 and CR47 and their 22k plus resistors, R35 and R33, respectively. The output is filtered by the active three-pole filter, U51 and associated components. The time constant of the integrator (U42) also effects the filtering. U42 integrates the signal at the summing-junction of the main amplifier and applies it to the non-inverting terminal of U37. The result is a high impedance input to Q36 which forms a unity gain high impedance buffer with U37. The ferrite beads, L45 and L46, on the bases of Q45 and Q46, respectively, keep the transistors from oscillating. The AC Converter output replaces the DC attenuator output to the integrator when the AC Mode is selected. The signal path is through Q74 and Q73, and into the integrator.

3-79. COMPLIANCE VOLTAGE LIMITER AND DETECTOR

3-80. This circuit operates when the instrument operates in the Current Mode. If the compliance voltage exceeds a 10 volt (2 volt on the 2A range) DC or peak AC preset limit, the voltage is clamped at that point and a visual indication (O.L. or Overload) is provided on the Central Display.

3-81. If the compliance voltage exceeds 10 volts, it is sensed at U84, which sets U96-5 and ID7 high to signal the instrument Controller an overload condition exists. At the same time, U100 is activated, turning on Q55, which turns off Q73, thereby disconnecting the feedback signal to the integrator and holding the output level until the overload is removed or the output switched to Standby. The clamping takes effect when CR81 (CR82) conducts, immediately after U84 turns on, dumping current into the power transistor Q81 (Q82). When the 2A range is selected, Q88 is turned on to shunt R88 and change the compliance sense voltage to approximately 2V dc or peak AC.

3-82. Power Amplifier

3-83. The Power Amplifier Assembly is made up of four independent amplifiers and a control logic section. The amplifiers are the high frequency, which may be used alone or in combination with one of the other amplifiers as determined by the output mode; the low frequency; the high current; and the isolation. The control logic energizes or de-energizes relays to control the output path as determined by the operating mode selected. Figure 3-12 and Table 3-1 are a simplified block diagram and

relay truth table showing the amplifier combination required for the various operating modes. The complete relay truth table for the Power Amplifier Assembly is in Section 8, located adjacent to the schematic.

3-84. HIGH FREQUENCY AMPLIFIER

3-85. The input state of the high frequency amplifier is the op amp U102. This is followed by a transistor amplifier with a local feedback for voltage gain and low output impedance. The output stage consists of

Table 3-1. Power Amp Relay Controls

	K3	K4	K7	K8	K11	K10
AC Volts less than 20 Volts	0	1	0	0	0	0
AC Volts 20–110 Volts 1 kHz to 20 kHz	0	1	0	0	0	0
AC Volts 20–110 Volts 50 Hz to 1 kHz	0	1	1	1	0	0
DC Volts less than 20 Volts	1	0	0	0	1	0
DC Volts 20–1100 Volts	0	1	1	1	0	0
AC Current less than 200 mA	0	1	1	1	0	0
AC Current more than 200 mA	0	1	0	1	0	0
DC Current less than 200 mA	1	0	1	1	1	0
DC Current more than 200 mA	1	0	0	1	1	0
AC Boost Mode	0	1	0	0	0	1
DC Boost Mode	1	0	0	0	1	1

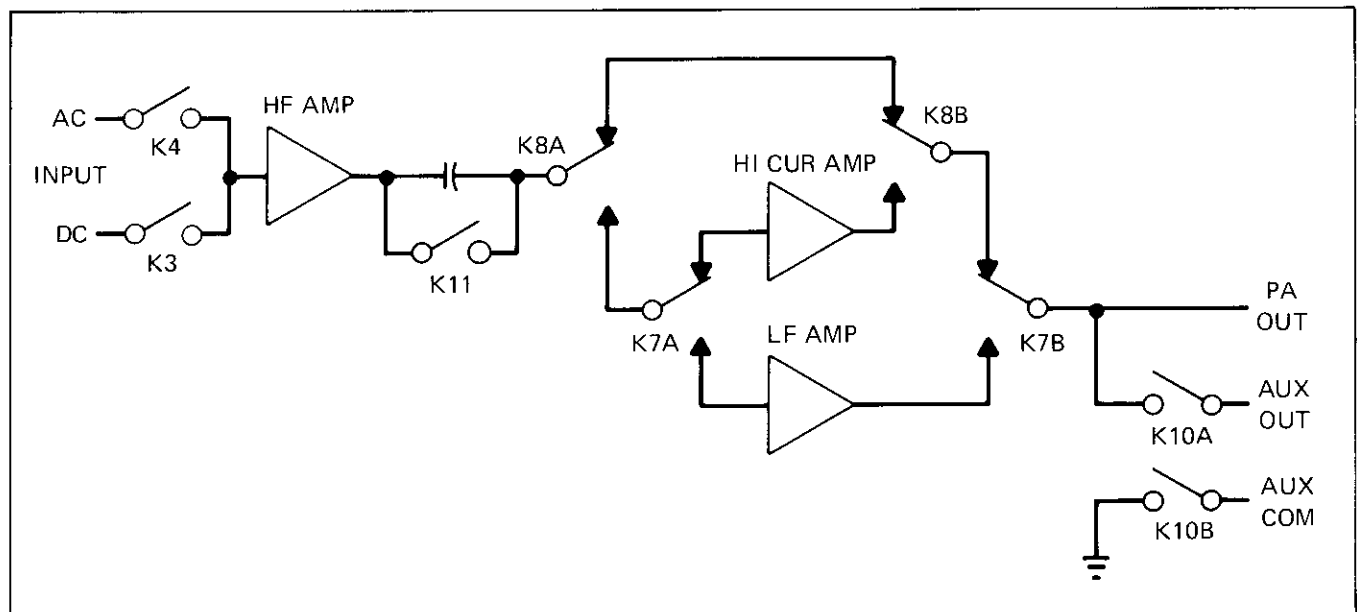

Figure 3-12. Power Amp Relay Controls

Darlington connected Q117/Q119 and Q118/Q120. Q115 and Q116 provide current limiting by monitoring R140 and R141. When the shunt voltage reaches approximately 0.6 volts, the transistors conduct by passing the base current from the Darlington pairs. A current limit condition also turns on the overload flag for the Controller by directing base current to Q2 through Q114. VR108 and VR109 provide a negative feedback clamp around U102 to prevent amplifier saturation during limit conditions.

3-86. LOW FREQUENCY AMPLIFIER

3-87. The low frequency amplifier may be used as either a voltage amplifier with low output impedance (e.g., to drive a transformer) or as a current source with high output impedance.

3-88. The input stage is the op amp U104 with the signal applied to the non-inverting input. A feedback path is provided through R186 to the inverting input. In the Voltage Mode (K5 energized, K2 de-energized) the contacts of K5 are closed, applying ground to one side of R151, resulting in a gain of approximately five. In the Current Mode (K2 energized, K5 de-energized) a positive feedback signal (PAFB) is applied through U105 to reduce the negative feedback.

3-89. The output stage is quasi-complementary with the driver transistor Q131 and Q133 the complementary pair. Current limiting is provided by Q129 and Q130 when the drop across R182 and R183 reaches approximately 0.6 volts. At the same time, the instrument Controller is notified of the overload when P82-23 goes low as a result of Q1/Q135 conducting through the action of Q128 and/or Q127. The zeners VR110 and VR111 provide negative feedback clamping for the input op amp to prevent amplifier saturation during the current limit conditions.

3-90. HIGH CURRENT AMPLIFIER

3-91. The High Current Amplifier is used only for current outputs equal to or greater than 200 mA. The op amp U106 is the input stage and the output stages are the complementary Darlington output transistors Q142 and Q143. Q140 and Q141 provide current limit protection and turn on the overload flag (Q2 and Q135) for Controller notification.

3-92. ISOLATION AMPLIFIER

3-93. Isolation between the Analog Control Assembly floating ground and the High Frequency Amplifier S-ground is maintained by the Isolation Amplifier. The input signal, either AC or DC, from the Analog Control Assembly is applied to U101-1, which is connected, as determined by the state of the FET switches Q101, Q102,

as either a unity gain follower amplifier (switches open) or unity gain inverter (switches closed). The relay configuration for each function can be found in the table adjacent to the schematic in Section 8.

3-94. For DC signals the output of U101-1 goes to U101-4 through the contacts of K3B. U101-4 is connected as a voltage-to-current converter and produces a current in the LED sections of U108 (positive) or U109 (negative) proportional to the input voltage. If U108 is turned on, the phototransistor section conducts a current from the +15V supply through K3A into the summing network of the high frequency amplifier input, U102. In the reverse condition, U109 conducts from the -215V supply to the summing network. As a result, the analog control output signal referenced to F-ground is able to produce a proportional input current to the High Frequency Amplifier, which is referenced to S-ground.

3-95. When the High Frequency Amplifier inputs are AC signals the output of U101-1 is connected through K4B to U101-2. The U101-2/Q103 combination produces a current to control the phototransistor U103, and through it, the resistance element in series with the oscillator. U107 is also turned on and applies a negative feedback to the summing-junction of U101-2, converting the input to a proportional change in the resistance of U103 and a proportional change in the magnitude of the AC signal input to the High Frequency Amplifier.

3-96. The variable resistor, R17, sets the gain of the Isolation Amplifier. Negative feedback is provided by C6 and R20 for transient conditions to avoid saturation and overshoot in the amplifier.

3-97. CONTROL LOGIC

3-98. The control logic decodes the microprocessor commands to the power amplifier and energizes the relays that direct the signal path with the decoded commands. The control lines plus ID0 or ID1 are decoded by U1-6 or U1-8 to clock U3 or U4 respectively and latch the data line information. The data lines contain the configuration to energize or de-energize the relays required, as determined by the microprocessor program for the function selected.

3-99. Extended High Voltage

3-100. Outputs of the power amplifier higher than 20 volts are routed to the Extended High Voltage Assembly. The assembly contains a high voltage transformer, a rectifier, and filter circuit, and the relay control logic for the relay contacts that control the signal path.

3-101. AC outputs between 20 and 100 volts at frequencies greater than 1 kHz are routed through K3A to the high frequency transformer, T2, and then directly to the high voltage output.

3-102. AC outputs up to 265 volts at frequencies of 1 kHz or less, are routed through K1 to the high voltage transformer, T1, then through the energized contacts of K4 to the high voltage output. Outputs between 265 and 1000 volts go through K2 to reduce the number of primary windings and then output on the same path.

3-103. DC output voltages are input to the assembly as a modified 2 kHz square wave. For outputs between 20 and 200 volts the signal goes to T1 through K1, and then through the de-energized contacts of K4 to the rectifier, CR8 through CR11. Polarity is established by the condition of K5, de-energized for positive outputs and energized for negative. The signal is then filtered by an active filter, U1, and output through K6 and K7. Outputs between 200 and 1000 volts dc are routed to T1 through K2 to reduce the primary coils and increase the secondary output. All other steps are the same.

3-104. Control lines 0, 3, and 4 high are decoded at U7-8 to clock the information from the microprocessor on the data lines into U3. The latched data controls the energizing and/or de-energizing of the relays that control signal paths. Relay status for each possible function is given on the Extended High Voltage Assembly schematic in Section 8. In addition to latching the data for the relays, the signal at U7-8 performs several other functions. One of these is the generation of the ACK signal so that the Controller knows the data has been received. The first time the signal is generated at power application, U7-6 is set to enable U8-2. Each signal after that fires the retriggerable one-shot, U9. If the pulse period of approximately 4.5 seconds passes without the assembly being accessed again to retrigger the one-shot, the trailing edge of the U9 pulse will clock U8-3 to generate POP (through U6-6) and reset the analog control circuits. This insures no dangerous outputs are present if the Controller becomes inactive.

3-105. Oscillator

3-106. The Oscillator Assembly uses 360 degrees of phase shift, obtained through two integrators and an inverter, to obtain their required oscillation. The frequency is selected by varying the resistors and capacitors on the integrators with FET switches controlled by the microprocessor. The range of oscillation is selected by the state of relays K1, K2, and K3 which add capacitance and resistance, through the selected FET switches, to the circuit. The range multiplier selection is controlled by the microprocessor which activates the applicable FET switches. The schematic in Section 8 includes a table giving the relay and FET switch control lines for each frequency combination. For example, a programmed output of 20V dc or greater would result in K1 and K5 energized and signals F1, F4A, and F4B high; a programmed output of 5 kHz would result in K3 and K5 energized, and signal F4A high.

3-107. Feedback, through R11, makes U1 a unity gain inverter. U4 provides an additional 90 degrees of phase shift and the feedback is added to U1 through R1, R4, R8, and Q1, which acts as a variable voltage controller resistor. The output signal is added to the feedback through R2.

3-108. The oscillator operates with a fixed output amplitude. A four-phase signal is formed with the input and output of U1, the 90 degree shifted output of U4 (available at TP5), and the output of the U2, which inverts the output of U4. These outputs, when rectified by the four-phase rectifier, CR1 through CR4, and integrated by U3, provide a low ripple signal to compare against the voltage reference VR1. The circuit uses U3 as an amplifier, set so that above 1 kHz the gain is rolled off by Q3 and below 1 kHz, through Q2, the gain climbs to keep the loop stable and to prevent oscillator ringing.

3-109. To prevent long delay times, waiting for settling in the low frequency ranges, C10 and C17 are precharged to zero and -1.7 volts, respectively. This allows the oscillator to start oscillating immediately when the lower frequency ranges are selected.

3-110. Capacitors C40 and C41, compensate for phase errors from U1 at high frequencies. The integrators U4 and U5 use C42 and C43, respectively, for a signal capacitor feedback to add a compensating signal at a frequency approximately equal to the break frequency of the amplifier. R50 adjusts the total phase error of the oscillator at high frequencies and is set so the control voltage at TP2 remains approximately constant at frequencies above 20 kHz.

3-111. To obtain the symmetrical square wave output required by the Extended High Voltage Assembly for high voltage DC outputs, K5A is energized and the signal routed through U14 and its associated components where it is clipped and rectified. From there it goes out through K5B to the power amplifier input.

3-112. When EXT OSC is selected on the front panel, K6 is energized and K4 is de-energized. This routes the external oscillator input at P91-39, which originates on the rear panel, directly out to the power amp on P91-37.

3-113. Digital control of the circuit originates when U10-12 decodes the proper information on the control lines and clocks the data on the data lines into U8 and U9. The data in U8 controls relay and rectifier operation and in U9 the FET switches for frequency range multipliers.

3-114. Ranging Assembly

3-115. The Ranging Assembly provides the path for the output signal from the power amplifier or high voltage output to the output and sense terminals. The data on the Digital Bus from the microprocessor is decoded by the logic circuitry (U5 through U18) to operate a series of relays and photocouplers which direct the path of the analog output through the assembly. The relays and photocouplers energized for a function and range are given in the chart on the Ranging Assembly schematic in Section 8.

3-116. The analog circuitry controls the output signal, steering it, either directly to the output and sense terminals, or through a divider network. The path is through the relay contacts controlled by the digital section. The paths for the various output ranges are detailed in the following paragraphs.

3-117. READINGS OF THE 2V TO 19.9999V RANGE

3-118. The power amp output is input at P41-16/36, is routed through the energized contacts of K18 and the de-energized contacts of K56B to the OUTPUT HI terminal. OUTPUT LO is tied directly to ∇ s. External sensing is from the HI terminal through de-energized K56A and K1D, energized K12, the resistor network to ∇ R and back to the I.O terminal. Part of the signal is picked off through K14 and sent to the Analog Control Assembly via P44, the DC ATTN cable. If internal sensing is selected, the HI and LO SENSE terminals are connected directly to the applicable OUTPUT terminal through the energized contacts of K55.

3-119. The AC path is the same to the output terminals. The path for external sensing is through K13A instead of K12, used with the DC. A portion of the sensing is picked off through K13A and routed to U2 for the buffered AC signal at P41-21. Internal sensing is through the contacts of K55 as in DC.

3-120. If external sensing and the 50 ohm override are selected for DC outputs less than 2 volts or AC output less than 200 mV, sensing is as described in the preceding paragraphs.

3-121. READINGS OF LESS THAN 1.99999V

3-122. DC outputs on the 2V, 200 mV, and 20 mV ranges are routed through either the energized contacts of K50, K51, or K52, respectively, the energized contacts of K57, the de-energized contacts of K56B to the OUTPUT terminal. OUTPUT LO is connected to ∇ s at the bottom of the mV divider. Sensing is internally, through the contacts of K55, with the pick-off for U2 through K53

and K54, respectively. The 2V ac range path to the output terminal is the same as the dc path for the 2V range. The pick-off for U2 and the buffered AC is through K16 and external sensing is available.

3-124. GREATER THAN 20V RANGES

3-125. Both the 200V dc and 1100V dc range outputs originate at the Extended High Voltage Assembly and are routed to the OUTPUT HI terminal through the energized contacts of K56B. SENSE HI is through the energized contacts of K56A and K10, the divider, and back to SENSE LO. The DC ATTN pick-off is through the energized contacts of K14 for the 20V dc range and through the FET switch Q1 (enabled by photocoupler U20B and Q4) for the 1100V dc range.

3-126. The 200V dc and 1100V dc range outputs use the same path to the OUTPUT terminals. The sense lines use F9 for the 200V ac range, K10 for the 1100V dc range with Q2 (enabled by U20A) providing the input for U2.

3-127. OHMS

3-128. The low ohms outputs use the energized contacts of K3 to provide a path from the bottom of the divider to SENSE LO through ∇ R. The bottom of the divider is also connected to OUTPUT LO through K1B and a ground. The paths from the top of the divider to OUTPUT and SENSE HI are through the energized contacts of the applicable relay (A for output, B for sense). Relays K4, K5, K6, K7, and K8 are energized individually for ohms ranges 1, 10, 100, 1k, and 10 kohms, respectively.

3-129. Internal sensing is automatically selected from the microprocessor through K55 when the 100k, 1M, and 10M ranges are selected. The high ohm divider (R21 through R39, less R32) outputs 100k with K9, K55, and K56 energized, 1M with K10, K55, and K56 energized, and 10M with K55 and K56 energized.

3-130. CURRENT

3-131. The current ranges use the low ohm shunts as current shunts in series between the power amp output and OUTPUT HI. Relay K3 connects the floating ground ∇ R to the PA output (P41-16) so that it floats above OUTPUT I.O by the output of the power amp. Relays, K4, K5, K6, K7, and K8 are energized for the 2A, 100 mA, 20 mA, 2 mA, and 200 μ A ranges, respectively, to connect the "A" contacts to OUTPUT HI and the "B" contacts to SENSE HI.

3-132. For DC current, U19 is enabled to provide a path for the sense to DC ATTN on P44. K16 provides the path to U2 when AC current is selected. With K1 energized, contacts "C" enable the I Guard Driver U1, which is a follower, for the PAFB output (P41-35) for current feed back to maintain the approximately constant loop gain of the power amp. It also assists in the power amp operation as a relatively high impedance current source and can be used from the front panel to reduce high frequency errors.

3-133. DIGITAL CIRCUITRY

3-134. When directly addressed with the correct output from the microprocessor on the IC line, U5-12 clocks the data on line ID0 through ID4 into U6. Relays K57, K55, K17, and K18 may be energized from U6, provided the required data is the ID line. If ID0 is high, U5-5 and U5-9 are enabled for indirect addressing. With the indirect address from the microprocessor, U5-9 latches the data on line ID0 through ID8 into U7 and U8 and/or U5-6 latches, then into U9 and U10. The data in the latches is decoded to energize the relays required (as shown in the chart) for the range and function selected. The data stays latched until the function and/or range is altered.

3-135. Controller

3-136. Under the direction of the software program, the Controller addresses and sets up each of the modules necessary to perform a function. Two types of addresses are used: direct and indirect. An indirect address requires a previous direct address to set up the indirect address response logic. Data transfers are accomplished with a handshake between the address (IC) lines and the acknowledge (ACK) line. When the Controller addresses a module, it places data on the data (ID) lines or receives data from the addressed module. The addressed module responds with an ACK signal, signifying that it is receiving or sending data. On initial power-up, the Controller checks the ACK signal from each module to insure that module is installed. If any fail to respond, due to either absence or a failure, error message (ERR6) is displayed.

3-137. The Controller is structured around the Intel 8080 microprocessor. Figure 3-11 is a block diagram of the Controller module. Hardware control functions have been minimized by careful software design. Sequences of events are timed from two sources. Basic operations of the microprocessor are run from a 1.7 MHz clock. The other source is generated by real time clock pulses at approximately 60 Hz, which are applied to a phase-locked loop. The phase-locked loop multiplies the real time clock frequency by eight. This signal is used to generate mark interrupts which time the background process.

3-138. The Controller has four 1024 bit RAMs installed on the PCB for use as temporary storage of data by the microprocessor. The amount and location of the memory devoted to the software varies with the model within the series and is covered later in this paragraph. Data lines (DB0-DB7) are used for bidirectional data flow. Address lines (A0-A15) determine the source or storage location of data. Since other modules of the 5100 Series B are addressed as memory locations, address and data I/O controls are used for access to the external bus structure.

3-139. Interrupts are used to divert the microprocessor from the main program to service other routines. Interrupts are synchronized to an appropriate time in the microprocessor cycle through interrupt control, where assigned priorities vector module identity data onto the Data Bus. Module identity data words direct the microprocessor to the memory location containing the next instruction. Two interrupts are internally generated: ACK INT and MARK INT (priorities one and six, respectively).

3-140. An interrupt may be externally requested by pulling the INT line lower. When the microprocessor is ready to accept the interrupt, the interrupt acknowledge (INA) signal is generated. The requesting module must respond with an ACK and a data bit (on ID1-ID4) which is used as a priority vector by INT CONTROL.

3-141. Two types of resets may occur: software and hardware. Software resets are a result of a remote request. Hardware resets occur at power-up or power-down. Real time clock pulses from RT5 are sensed by the reset logic. At power-up the reset signal assures the microprocessor will start from program location zero. At power-down the reset signal assures the Controller will not call up wrong modules.

3-142. The microprocessor control logic is responsible for latching up a status word at the beginning of each instruction cycle and for telling the microprocessor when to enter and exit wait states. Microprocessor sequences are divided into machine states (one clock period, 588 ns), machine cycles (from three to five states), and instruction cycles (from one to five machine cycles). Status words are used to control and synchronize data I/O, memory read/write, and some of the interrupt control signals. The microprocessor must be instructed to enter a wait state after addressing an external module and after being interrupted to allow the external module time to respond.

3-143. Memory for non-storage instruments (5100B, and 5102B) consists of five ROMs installed on the PROM-ROM-RAM PCB. The RAMs required for the program are installed on the Controller PCB. The PROM-ROM-RAM PCB is attached to the Controller

PCB electrically and mechanically and does not have a connection to the bus on the motherboard. As a result of the connection, both boards are removed as an assembly.

3-144. Memory for the storage instruments (5101B) consists of seven PROMs and six RAMs installed on the PROM-ROM-RAM PCB. The board does not have a direct connection to the bus, drawing power, data, and addressing from the Controller Assembly.

3-145. Front Panel

3-146. The control lines from the Controller microprocessor (IC0 through IC6) are decoded by U22 and U23 to set up a series of control operations within the Front Panel. The output of U23-10 (LD DIG) loads the contents of the data lines into U1 and U9 to enable, if at the correct level, Q1 through Q8, and through them, enable the LED indicators, at the same time U1 and U9 via output lines B0 through B6, enable the Front Panel key switches. The one-shot U12 clears U1 and U9 when the clock is removed.

3-147. The decoded signals at U23-9, U23-6, and U23-10 clock the contents of the data lines into U2 and U3, U4 and U5, and U6, respectively. These provide the low required to illuminate the LED indicators, provided the data on the lines selected the indicator.

3-148. A decoded signal at U22-9 (RSDW) enables the output of the key switch matrix. A depressed key switch in an enabled bank causes an output on the applicable data line.

3-149. The edit circuit is enabled with a low at U22-6. Movement of the EDIT switch (S51) outputs a signal on the data lines.

3-150. Any decoded signal at U22 or U23 generates ACK signal to the microprocessor through U28 and Q9. This informs the Controller that the Front Panel has received the instructions.

3-151. Guard Isolator

3-152. The isolator accepts parallel data, shifts it to serial format for transfer across isolation transformers, and converts it back to the parallel format. The module reads the address on the Unguarded Control Lines (IC0 through IC6) and, if the data is destined for one of the analog modules, shifts it across the isolation transformers and places it on the Analog Bus. When the Controller requests data, the address on the Guarded Control Lines is decoded and the data bit from the analog module transmitted on ID7 to the Controller. A more detailed explanation using the block diagram in Figure 3-13 follows.

3-153. When data (ID0 through ID7) is destined for an analog module the address is decoded by the control logic circuitry which disables the clock (7.5 MHz), clears the guarded shift registers, and enables the unguarded shift register to load the parallel data. After a built-in time delay the clock resumes and begins shifting the data through the isolation transformers into the guarded shift registers to the output. Completion of the transfer is decoded by the return logic to enable and pass through the isolation transformer to the control logic, the ACK (Acknowledge) signal generated by the receiving analog module.

3-154. When the Controller requests data from an analog module, the same sequence repeats itself through the output of the address. The address output is decoded by the return logic, returning the status of the addressed module through the return logic and isolation transformer to the control logic and, on the Unguarded Bus, to the Controller.

3-155. Tape Interface (Storage Only)

3-156. The Tape Interface Assembly links the Raymond mini-cassette tape system and the instrument Controller, through the Internal Bus. It sends to the cassette system operational commands originating from the Controller, and accepts and transmits to the Controller system any data transfer status information. The interface also converts and coordinates data flow between the cassette system, with its serial format, and the Controller, with its parallel format. Operation of the interface is divided into the control, status, write, read, and interrupt circuits, each of which is discussed further below.

3-157. CONTROL CIRCUIT

3-158. The interface responds to four control commands: interrupt enable, move, rewind, and write. The cassette system responds to the control line MOTION (move), FWD/RWND (Rewind), and READ/WRITE (Write) to perform the indicated operation. The interrupt enable command controls the operation of the interrupt circuit. The commands are received by the interface on the Data Bus and latched into U23.

3-159. STATUS CIRCUIT

3-160. These circuits return the cassette system and interface operational status to the Controller. The cassette system status returned is CASSETTE LOADED, SIDE A/B, WRITE INHIBIT, and TAPE POSITION. The interface status returned is EOR (End Of Record), DAV (Data Valid), RFD (Ready For Data), and BSY (Interface Busy). The data is encoded in eight parallel-bits and transferred to the Data Bus when the correct address is decoded.

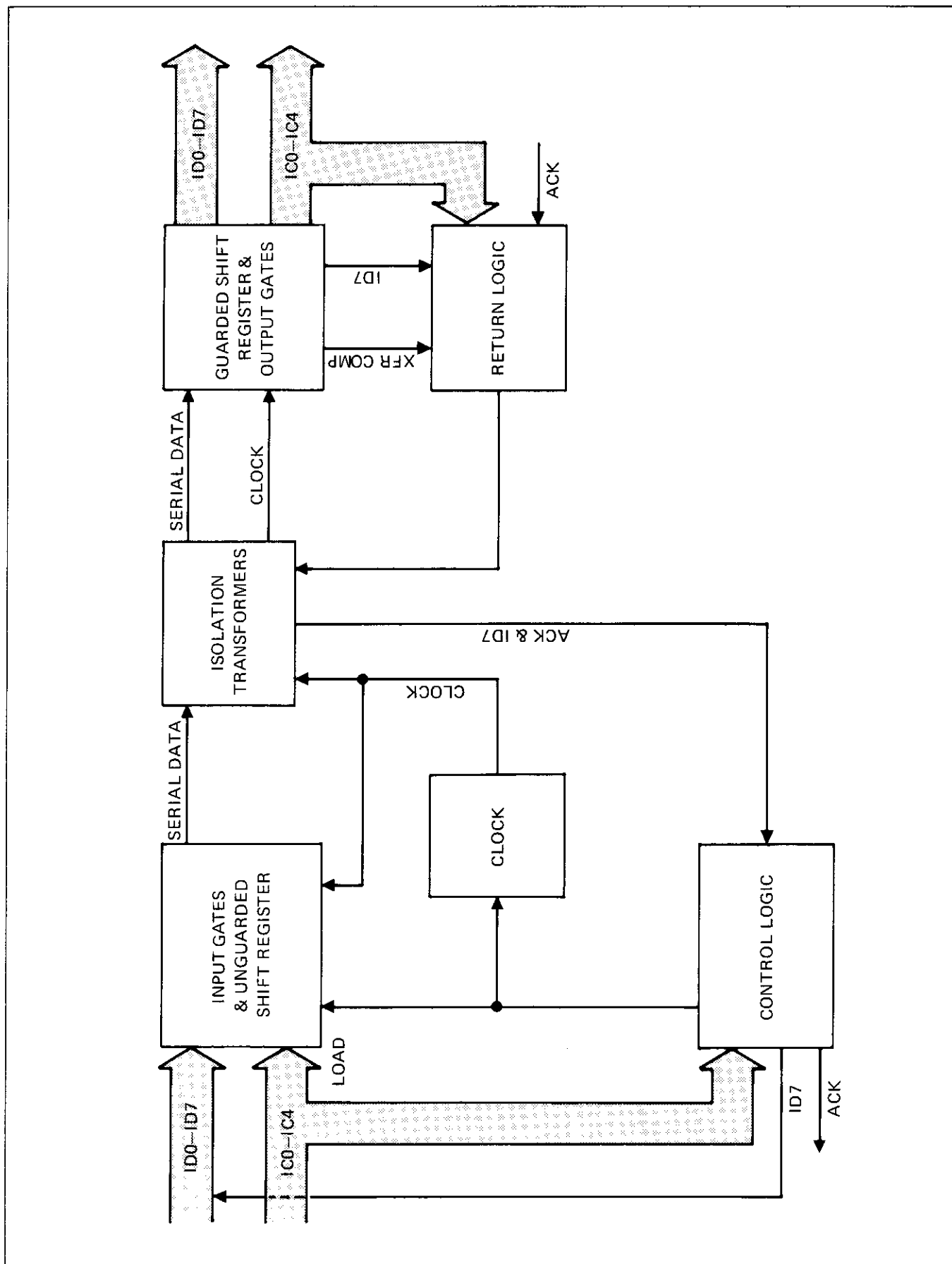

Figure 3-13. Isolator Block Diagram

3-161. WRITE CIRCUIT

3-162. The write circuit converts the data destined for tape storage from the parallel format of the Controller to the phase-encoded bit-serial format of the cassette system.

3-163. The free-running oscillator, U1, provides timing at 9.6 kHz, which is divided twice by U25 to produce clocks at 4.8 kHz and 2.4 kHz. The two are combined to generate two clocks to either load the shift register (U6) from the parallel input (U7, U8) or shift the data out of the register in the phase-encoded serial format.

3-164. At time T1 (Figure 3-14), the Controller generated address is decoded at U9-6 to set \overline{RFD} (U5-9), not ready for data, high and to move ID0 through ID7 into the latches U7 and U8. Transfer to the shift register is accomplished by a pulse at U3-4 and is synchronized with the master clock by U2. BSY (Busy), at time T2, sets U2-1 to indicate the data is being clocked out of the register and resets \overline{RFD} to signal the Controller that it is ready to accept the next data byte. Each bit shifted out is latched, in turn, into U5 and then phase-encoded in U10. At time T3 the Controller outputs the next data byte to the interface for loading into the latches U7 and U8, and to set RFD high. The number of bits shifted is counted by U11, and when it reaches eight, BSY is reset and a new load

pulse is generated at time T4. The sequence continues until the final bit is shifted out so that BSY remains low and there are no additional shift pulses generated, as in T5.

3-165. READ CIRCUIT

3-166. Operation of the read circuit is the reverse of the write circuit. Data is read from the tape in a phase-encoded bit-serial format, decoded, and then output to the Controller in the parallel format required.

3-167. When the data read from the tape at U10-13 changes, a spike is generated at U10-11, causing a 1 us pulse at U12-5 (Figure 3-15). The approximately 301 us clock from U13 clocks the tape data into U18. The trailing edge of the pulse clocks the counter U14 to count the number of data bits read. When eight bits have been read U14-2 goes high, resetting the counter, loading the latches U19 and U20 from the shift register, and setting the DAV latch (U4-10/U4-11) to signify data is available (DAV). When the Controller inputs the data from the tape interface, the DAV latch is reset, enabling the interface, for when the next eight bits of data are available. The output at U12-4 has been held low from the first data transition of a tape reading operation. After data transfer is complete the point goes high, signaling the Controller the completion of data transfer.

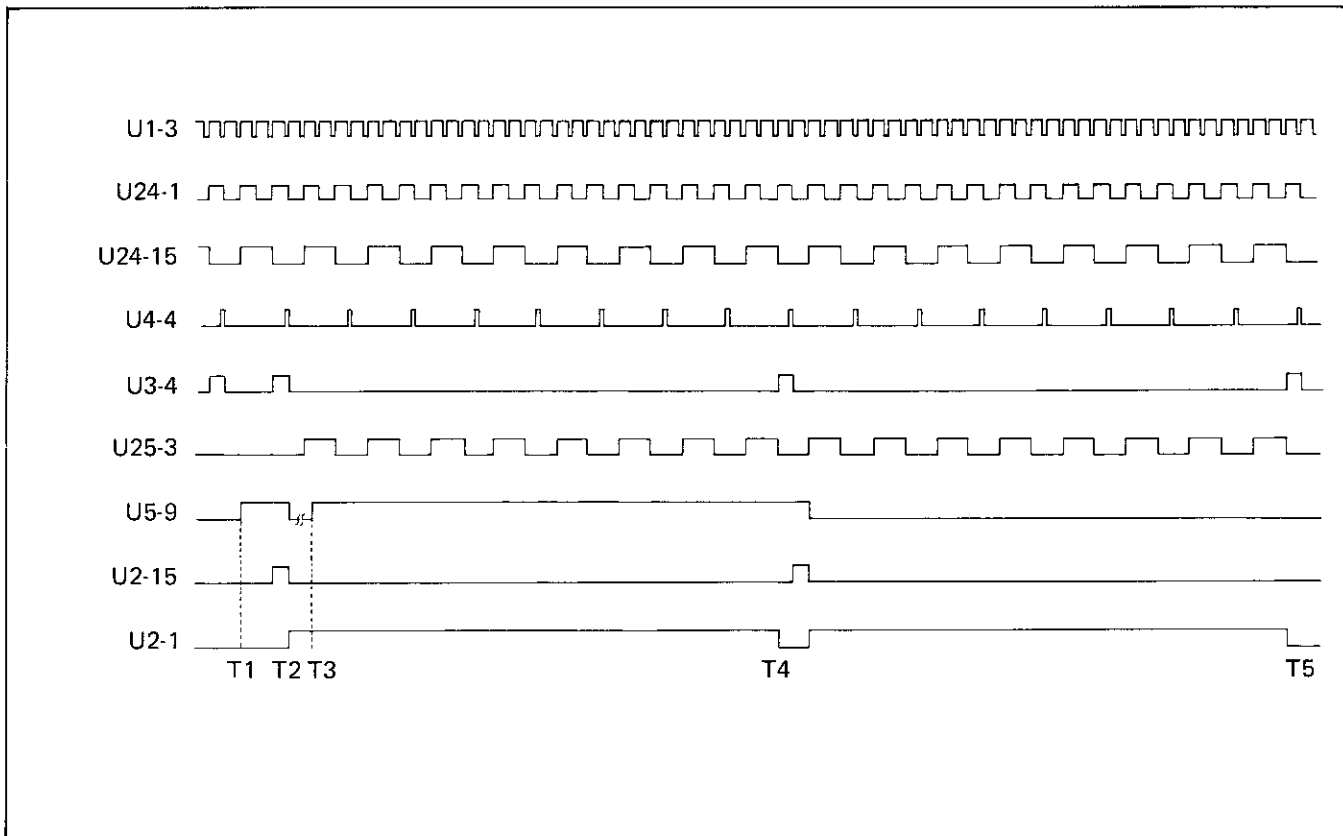

Figure 3-14. Write Timing Diagram (Storage Only)

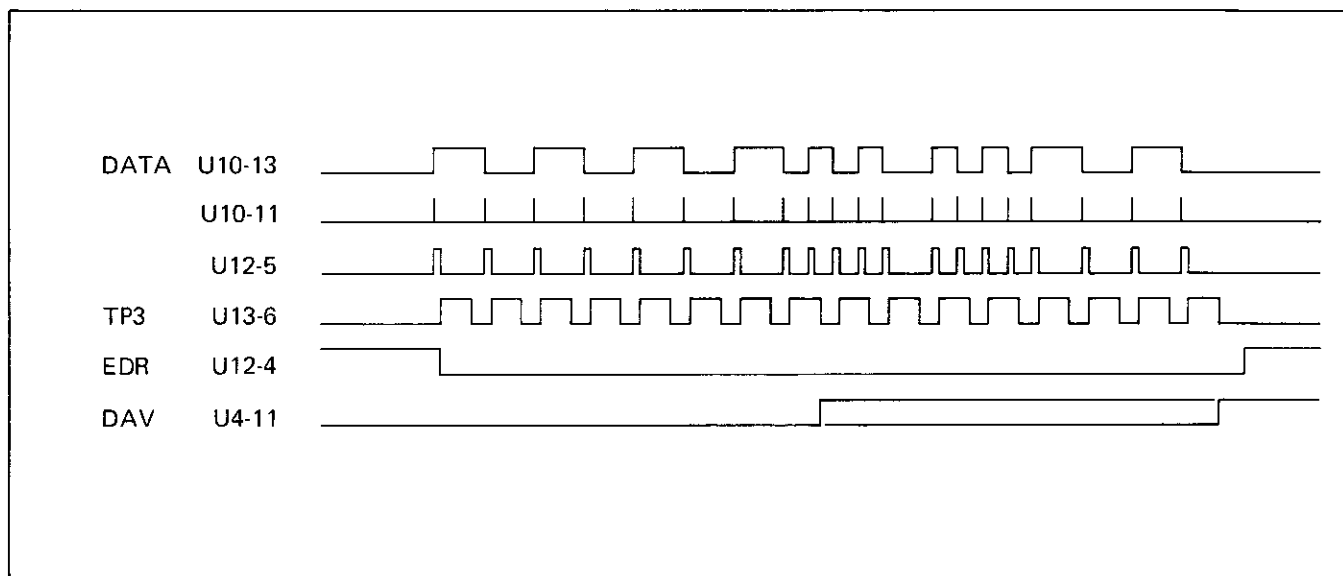

Figure 3-15. Read Timing Diagram (Storage Only)

3-168. INTERRUPT CIRCUIT

3-169. The interrupt circuit notifies the instrument Controller when the interface is ready to input data or accept additional output data. An interrupt enable (\overline{INT}) control signal is generated at the start of an interrupt and removed when a valid input data address is decoded.

3-170. Generation of either a DAV (Read Cycle) or \overline{RFD} (Write Cycle) resets the applicable portion of U26 to

generate an \overline{INT} for transmission to the Controller. When the interface receives an interrupt acknowledge (INA) in return and \overline{INT} is valid, it sets data line ID1 high and generates acknowledge (ACK) for the Controller. Setting ID1 high signifies the interrupt is from the tape interface. The interrupt is removed on signal from the Controller. The interrupt is also automatically reset at power on from U10-3 to insure the instrument does not come up with the interrupt active.



Section 4

Maintenance

WARNING

THESE SERVICING INSTRUCTIONS ARE FOR USE BY QUALIFIED PERSONNEL ONLY. TO AVOID ELECTRIC SHOCK, DO NOT PERFORM ANY SERVICING OTHER THAN THAT CONTAINED IN THE OPERATING INSTRUCTIONS UNLESS YOU ARE QUALIFIED TO DO SO.

4-1. INTRODUCTION

4-2. This section contains information on general maintenance, troubleshooting, selected component replacement, calibration procedures, and a performance test. The performance test can be used upon receipt of the calibrator as an acceptance test or at any other time, to verify the correct operation of the instrument.

4-3. SERVICE INFORMATION

4-4. Each instrument manufactured by the John Fluke Mfg. Co., Inc. is warranted for a period of 1-year upon delivery to the original purchaser. The WARRANTY is located at the front of the manual.

4-5. Factory authorized calibration and service for each Fluke product is available at various worldwide locations. A complete list of domestic service centers is located at the rear of the manual. Shipping information is given in Section 2, if requested, the customer will be provided an estimate before any work begins on instruments that are beyond the Warranty period.

4-6. GENERAL MAINTENANCE

4-7. Cleaning

4-8. Periodically (at least every 180 days) clean the instrument using the following procedure:

1. Insure that power is removed from the instrument.

2. Remove the top and bottom covers from the instrument.

3. Disconnect the PCB assemblies from the motherboard and remove them from the instrument.

4. Clean the interior of the instrument using low pressure, clean, dry air, or a vacuum cleaner.

5. Clean the Front Panel and exterior surfaces with anhydrous ethyl alcohol or a soft cloth dampened with a mild solution of detergent and water.

6. Replace the PCB assemblies and covers if access to the instrument interior is no longer required.

4-9. Air Filter Maintenance

4-10. Visually inspect the air filter at the rear of the fan compartment periodically for dirt and contaminants. If cleaning is required, use the following procedure:

1. Insure that power is removed from the instrument and the fan is not operating.

2. Apply inward pressure to the top and bottom of the filter bracket then pull to the rear until the filter and bracket are free from the instrument.

- Clean the filter using either low pressure, clean, dry air, or a water and mild detergent solution.

NOTE

If water is used for cleaning, insure that the filter is dried thoroughly before reinstalling.

- Reinstall the filter by inserting the bottom into the frame first then pushing in on the top of the filter.

4-11. Line Voltage Selection

4-12. The calibrator is set at the factory to operate at a line voltage of 115 volts $\pm 10\%$ with a frequency of 50 to 60 Hz. Three switches in the power supply (Figure 4-1) permit the selection of one-of-eight possible input line voltage ranges shown in Table 4-1. (The switch position settings are also screened on the calibrator inner cover.) The table gives each possible voltage and its high and low tolerance. Select the setting for use with the local line voltage that includes the expected fluctuations in the local line voltage.

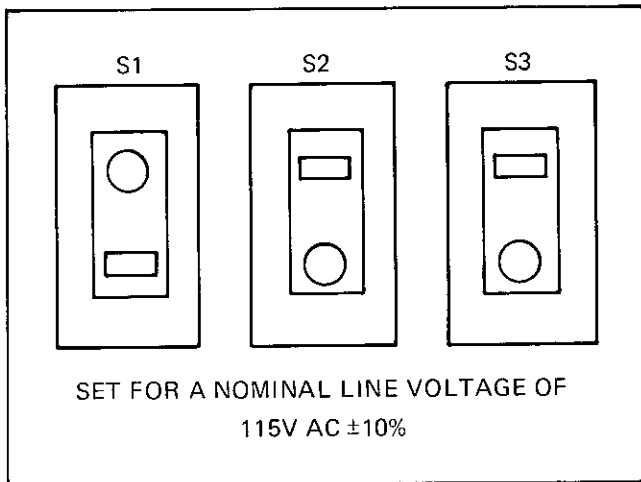

Figure 4-1. Input Line Voltage Switches

4-13. Fuse Replacement

4-14. Insure that the proper fuse is installed for the input line voltage selected from the values below:

110 to 120 volt range selected - MDX 2A

200 to 240 volt range selected - MDL 1A

4-15. Instrument Assembly/Disassembly

4-16. The 5100 Series B instruments can be easily disassembled by sections to gain access to any component within the instrument. In most cases, some previous step

in the disassembly process will be required and the procedure will refer to that step. Removal of the top cover is the first step in disassembly for instruments with standard cases. Instructions for assembly/disassembly of instruments with the fiberglass case are in later subparagraphs of this procedure.

CAUTION

Use static awareness precautions during instrument disassembly or assembly. Do not allow the PCB card-edge connectors or the cable connector pins to come in contact with any ungrounded object, including personnel, since static charges in excess of the damage point (approximately 60 volts) can build up on these objects. The damage incurred may not be apparent immediately, it may appear up to three months after the incident occurs. The PCB digital input card-edge connector should be inserted into a connector with all pins shorted to make all points common any time the assembly is removed from the instrument. Refer to the yellow insert sheet on static awareness in an earlier section of this manual for further details.

Table 4-1. Input Line Voltage Switch Settings

LINE VOLTAGE			POSITION OF COLOR DOT		
-10%	NOMINAL	+10%	S1	S2	S3
90	100	110	Up	Up	Down
99	110	121	Up	Up	Up
103.5	115	126.5	Up	Down	Down
108	120	132	Up	Down	Up
180	200	220	Down	Up	Down
198	220	242	Down	Up	Up
207	230	253	Down	Down	Down
216	240	264	Down	Down	Up

4-17. Reassembly of the instrument should be performed in the reverse order, as required, unless noted otherwise.

4-18. FRONT PANEL PCB REMOVAL AND LED REPLACEMENT

4-19. Perform the disassembly of the Front Panel using the following procedure:

- Remove any shorting links on the output terminals.

2. Remove the screws securing the bottom cover to the front panel.
3. Loosen or remove the screws on each side, directly to the rear of the front handles and, if applicable, the screws attaching the side bars to the inner frame (fiberglass case only).
4. Slide the Front Panel and attached PCBs forward, insuring they clear the output terminals.

NOTE

Disassembly operations requiring only the forward movement of the Front Panel to free the output terminals cease at this point.

5. Disconnect the ribbon cables connecting the Front Panel to the power supply interconnect board when the connectors become accessible.
6. The front panel, Front Panel PCB, and shield are now free and may be lifted away from the instrument, allowing removal of the Front Panel to gain access to the LEDs on the Front Panel PCB.
7. Defective LEDs on the Output and Central Display may be replaced without removing the shield by lifting the small pcb assembly containing these indicators away from the Front Panel PCB. The shield must be removed from the rear of the PCB for access to the remainder of the LEDs.

4-20. TRANSFORMER AND PCB ASSEMBLY REMOVAL

4-21. Remove the transformer and its associated PCB assembly using the following procedure:

1. Remove the bottom cover.
2. Remove the screws (in a trapezoidal pattern) securing the transformer frame to the inner bottom.
3. Remove the screws (in a square pattern) securing the transformer frame to the side of the instrument.
4. Grasp the transformer firmly and lift the assembly straight up and out of the power supply compartment.

4-22. PCB ASSEMBLY REMOVAL

4-23. Remove the PCB assemblies using the following procedure:

1. If the Ranging PCB requires removal from the analog (main) compartment, slide the Front Panel

forward to clear the output terminals using the procedure described above.

2. To remove any PCB in the analog compartment, or the Power Supply Regulator PCB, insert the card puller (stored on the front bulkhead in the power supply compartment) into the hole provided at the top center of the PCB and lift straight up.

NOTE

The card puller is required since the space between the PCB's is insufficient to grasp the boards firmly.

3. Remove the PCBs from the digital (rear) compartment by grasping the boards firmly at each corner and pulling straight up.

NOTE

If the four section shield must be removed from the DAC PCB Assembly insure the cutaway portions for the photocoupler and pulse transformer are to the center on the component side and the two cutaway corners are to the center on the non-component side.

4-24. POWER SUPPLY COMPARTMENT SIDE PANEL REMOVAL

4-25. Remove the outside panel from the power supply compartment using the following procedure:

1. Remove the Front Panel using the procedure described above.
2. Remove the screws connecting the side panel to the rear panel.
3. Remove the screws attaching the front bulkhead, the center brace, the capacitor bracket, and the transformer assembly to the side panel.
4. Remove the screws attaching the bottom flange of the side panel to the inner bottom.
5. Slide the side panel forward, away from the rear panel, and lift it away from the instrument.

4-26. REAR PANEL REMOVAL

4-27. Remove the rear panel from the instrument using the following procedure:

1. Remove the plates around the DIGITAL CONNECTOR (J4) and the outboard screws around the ANALOG CONNECTOR (J2) cover.

2. Remove the screws attaching the bottom cover to the rear panel.
3. Remove the two screws on each side attaching the rear panel to the side panels, located directly in front of the corner braces with the decals. It is not necessary to remove the decals to remove the rear panel.
4. Disconnect the power cord connecting the fan to the power supply motherboard.
5. Move the rear panel straight back until the digital connector is free, then lift the rear panel away from the instrument.

4-28. MIS MOTHERBOARD REMOVAL

4-29. Remove the MIS Motherboard from the digital compartment of the instrument using the following procedure:

1. Remove the PCB assemblies from the digital compartment using the procedure described earlier.
2. Remove the rear panel from the instrument using the procedure described above.
3. Remove the two screws in the capacitor chamber (beneath the MIS Motherboard and only accessible with the rear panel removed) attaching the MIS Motherboard bracket to the frame.
4. Remove the left side screws and panel, then lift the MIS Motherboard, its bracket, and the connector PCB free from the instrument compartment.

4-30. MAIN MOTHERBOARD REMOVAL

4-31. Remove the main motherboard from the instrument using the following procedure:

1. Remove the PCB assemblies from the analog and digital compartments using the procedure described earlier.
2. Remove the MIS Motherboard from the instrument using the procedure described above.
3. Remove the twelve screws within the square pattern attaching the main motherboard to the instrument.

NOTE

Do not remove the screws in the round patterns from the main motherboard. These attach the bottom shield to the motherboard.

4. Remove the left side panel and lift the motherboard away from the instrument.

4-32. POWER SUPPLY REMOVAL

4-33. Remove the power supply from the instrument using the following procedure:

1. Remove the Power Supply Regulator PCB Assembly as described above.
2. Remove the rear panel from the instrument using the procedure described above.
3. Remove the Transformer and PCB Assembly using the procedure described above.
4. Remove the Power Supply Interconnect PCB from the front of the power supply motherboard by removing the two screws on the top and lifting the PCB straight up.
5. Remove the capacitor bracket (rear) and stud (front) from the power supply chamber of the instrument.
6. Disconnect J14 and J15 that connect the main motherboard to the power supply motherboard.
7. Remove the screws fastening the power supply motherboard to the frame.
8. Slide the power supply mother board out the rear of the instrument.
9. The capacitors in the capacitor chamber are an electrical part of the power supply and are accessible for inspection or maintenance with the rear panel removed.

4-34. ENVIRONMENTAL RESISTIVE CASE ASSEMBLY/DISASSEMBLY (FIBERGLASS CASE ONLY)

NOTE

All sections of the fiberglass case and covers are part of a serial numbered matched set that must be kept intact for maximum protection.

4-35. Remove the fiberglass case using the following procedure:

1. Insure the front cover is attached to the instrument then stand the instrument upright on its front cover.

2. Remove the line cord and the hex (Allenhead) screws along the side of the back panel.
3. Set the instrument upright on its rear panel.
4. Remove the front cover, the hex screws and associated plates, and the vent screen.
5. Lift off the front half of the fiberglass case.
6. Place the instrument flat; i.e., the normal operating position.
7. Support the inner chassis and slide the rear half of the fiberglass case off the instrument.

4-36. Replace the fiberglass case using the following procedure:

1. Set the instrument upright, on its rear panel.
2. Slide the front half of the case over the chassis, insuring the feet are on the correct side.
3. Install the vent screen (left side) and the plates using the hex screws previously removed. Install the washers on the screws holding the screen.
4. Install the front cover on the instrument and set the instrument upright on the front cover.
5. Slide the rear half of the case over the chassis, insuring the feet are on the correct side.
6. Install the case with hex screws, using the washers on the screws through the vent screen.

4-37. TAPE SYSTEM REMOVAL (STORAGE ONLY)

4-38. Remove the tape system from the calibrator using the following procedure:

1. Slide the Front Panel forward to gain access to the tape system using the procedure described previously.
2. Lift the tape access door on the Front Panel and remove the four screws securing the tape system to the Front Panel.
3. Disconnect the ribbon cable from the Tape Drive PCB and lift the tape system clear of the instrument.

NOTE

The Front Panel must be at its extreme forward limit for the tape system to clear the rear of the EDIT switch.

4. The tape drive may be separated from the Tape Drive PCB, if desired, by disconnecting the cable connecting the drive to the PCB and removing the four screws securing the drive to the PCB.

4-39. PERFORMANCE TEST

4-40. The following paragraphs contain a performance verification test which compares the outputs of the instrument to the specifications in Section 1 of this manual. The test may be used to verify calibration of the instrument between scheduled calibration periods, as an acceptance test, or as an aid in troubleshooting.

4-41. The test equipment required for the performance test is listed in Table 4-2. If the recommended equipment is not available, replacements with equivalent specifications may be substituted. The test must be performed when the ambient temperature is between 22 and 24 degrees Celsius, with the relative humidity less than 85%, to attain maximum accuracy.

4-42. If the instrument does not meet the error limits listed in the performance test either the calibration procedure or corrective maintenance should be performed, as determined by the symptoms.

4-43. Calibration Test Equipment Accuracy Considerations

4-44. Accurate calibration of the 5100 Series B Calibrators requires precision calibration standards and test equipment often accessible only in a standards lab. Calibration is normally performed using test equipment with accuracies four to ten times better than the instrument being calibrated. This criteria allows the errors of the test equipment to be ignored even though the possibility exists that the inherent errors of the test equipment could make the instrument read out of tolerance when good, or in tolerance when bad. An example of this problem using a four to one ratio and the uncertain area is shown in Figure 4-2.

4-45. The performance test for the 5100 Series B Calibrators contains tables used to verify the accuracy of the DC voltage and current, and the AC voltage. These tables have columns for the programmed output, both calibrator and test equipment, and the specified maximum allowable \pm error of the calibrator for the programmed output, in percent. In addition, highlighted columns have been added which list the maximum specified error in percent of the test equipment called out in the procedure; the summed errors of the calibrator and test equipment, and the difference when the possible test equipment error is subtracted from the possible calibrator error.

4-46. These last three columns, which are highlighted, are given as a convenience to the individual to use or not

use, as he determines, depending on the circumstances involved, and the desired degree of accuracy. In all cases, if any test equipment is replaced with a different model, the three columns must be recomputed.

4-47. Equipment Preparation

4-48. Perform the following procedure prior to beginning any operation. The equipment should have a

warmup period of at least 30 minutes prior to performing any test.

1. Verify that the instrument is set for the correct input line voltage range, using the procedure outlined earlier in this section.

2. Connect the calibrator to the input line power.

Table 4-2. Test Equipment

ITEM	SPECIFICATIONS (minimum)	NOMENCLATURE
DC Voltage Standard	0.001% Accuracy	Fluke 335D
Current Calibrator	25 ppm/hr Stability	Fluke 382A/3330B
Voltage Divider	0.1 ppm Resolution, 1 ppm Terminal Linearity	Fluke 720A
Ratio Transformer	0.5 ppm Terminal Linearity at 400 Hz	ESI DT72A
Null Detector	1 μ V Range	Fluke 845AB
Thermal Transfer Standard	0.02% @ 1000V Range, 0.01% @ other ranges	Fluke 540B
DC Differential Voltmeter	NMRR > 100 dB @ 400 Hz	Fluke 885A
RMS Differential Voltmeter	1 μ V Resolution	Fluke 931B
Digital Multimeter	5½ Digit 100 $\mu\Omega$ /1 μ V Resolution	Fluke 8500A/8400A/ 8375A/8425A
Digital Multimeter	Current Reading 1%	Fluke 8000A
Frequency Counter	50 Hz to 50 kHz >0.5 Accuracy (10 Hz to 10 MHz with -03 Option)	Fluke 1900A
Oscilloscope	>60 MHz Dual Trace at .5 mV/cm Sensitivity Amplifier	Tektronix w/Dual Trace Plug-In w/5A22N
Distortion Analyzer	50 Hz to 50 kHz >0.01% Accuracy	Soundtechnology ST1700B
Resistive Loads	100 Ω \pm 1%, ½W 33 Ω \pm 5%, 2W 2 k Ω \pm 5%, 2W 20 k Ω \pm 5%, 2W 33 k Ω \pm 5%, 2W 1 Ω \pm 1%, 5W 2 ea. 1 Ω \pm 5%, 2W in parallel = 0.5 Ω 4W	Metal Film Type Carbon Composition Type Carbon Composition Type Carbon Composition Type Carbon Composition Type Wire Wound Type Carbon Composition Type
Standard Resistor w/ Accessories	1 Ω at 50 ppm minimum 10 Ω and 1 M Ω at 25 ppm minimum 100 Ω , 1 k Ω , 10 k Ω , 100 k Ω at 10 ppm minimum 10 M Ω at 100 ppm minimum	ESI 1010 10 Ω , ESI 1010 1 k Ω , ESI 1050 1 M Ω , ESI SB103 Shorting Bars, ESI PC101 Parallel Compensation Network
Lowpass Filter	Construct of 1 k Ω resistor and 0.05 μ F capacitor in series	Metal Film Type Non-polarized
Extender PCB		Fluke 5100A-7001K

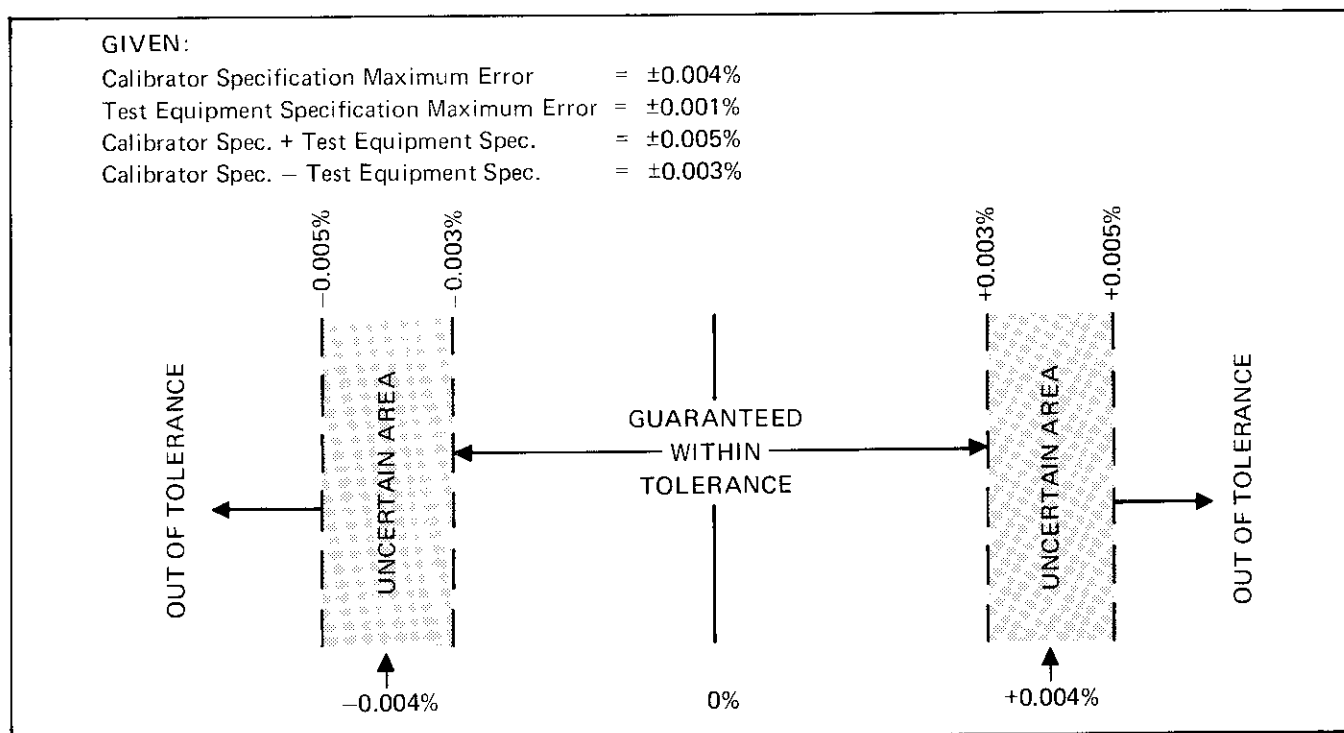

Figure 4-2. Accuracy Uncertainties

3. Depress the POWER switch to apply power to the instrument.
4. The Output Display reads $+0.0000$ mV and the STDBY, LOCAL, INT, and 50Ω DIVIDER indicators illuminate.
5. Make all interequipment connections, during the test, using low thermal EMF copper leads or coaxial cable, as applicable.

4-49. DC Offset Voltage

4-50. Perform the DC offset voltage test using the following procedure:

1. Depress the CLEAR keyswitch twice in succession.
2. The Front Panel indications blink, then read $+0.0000$ mV with only the STDBY, LOCAL, INT, and 50Ω DIVIDER indicators illuminated.
3. Prepare the test null detector to read a null ± 5 μ V, then connect the equipment as shown in Figure 4-3.
4. Select OPR on the calibrator.
5. Verify the null detector reads 0 ± 5 μ V.

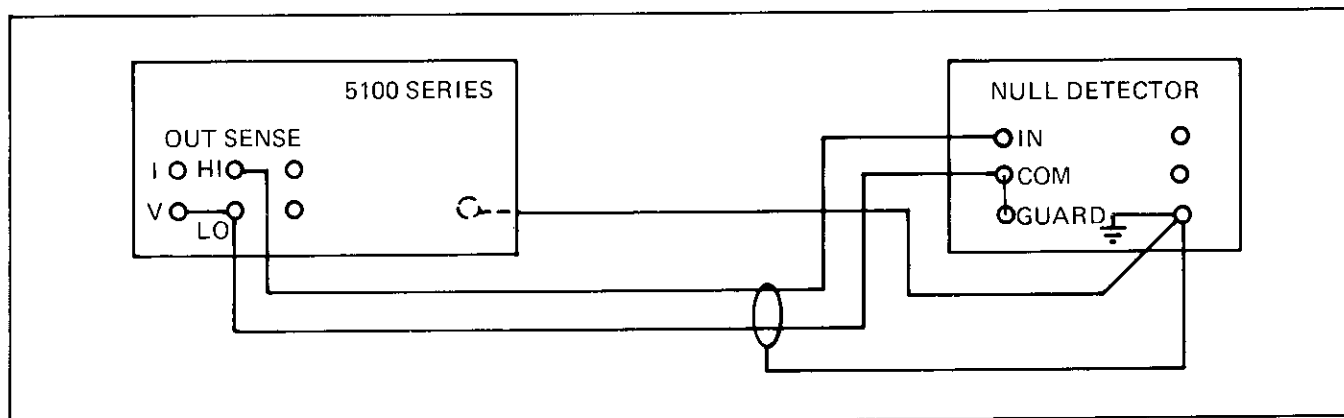

Figure 4-3. Offset Voltage Checks

6. Depress the 50Ω DIVIDER OVERRIDE keyswitch.
7. The OVERRIDE indicator illuminates.
8. Verify the null detector reads $0 \pm 205 \mu\text{V}$.
9. Select STDBY on the calibrator.

5. Enable the calibrator Error Mode and modify the calibrator output until a null is obtained on the null meter.
6. Verify the displayed error is no greater than the allowable error for the programmed calibrator output of the applicable step.
7. Select STDBY on the calibrator and test equipment.

4-51. DC Voltage Tests

4-52. Perform the DC voltage tests using the following procedure:

1. Select STDBY on the calibrator.
2. Connect the equipment as shown in Figure 4-4. Do not use the null detector built into the DC Voltage Standard.
3. Select the setting in step I of Table 4-3, for each of the instruments listed.
4. Select OPR on the test equipment and calibrator.

8. Repeat steps 3 through 7 for steps 2 through 4 of Table 4-3.
9. Connect the equipment as shown in Figure 4-5. Do not use the null detector built into the DC Voltage Standard.
10. Select the setting, in step 5 of Table 4-3, for each of the instruments listed.
11. Select OPR on the test equipment and calibrator.
12. Select the calibrator Error Mode and modify the calibrator output until a null is obtained on the null meter.

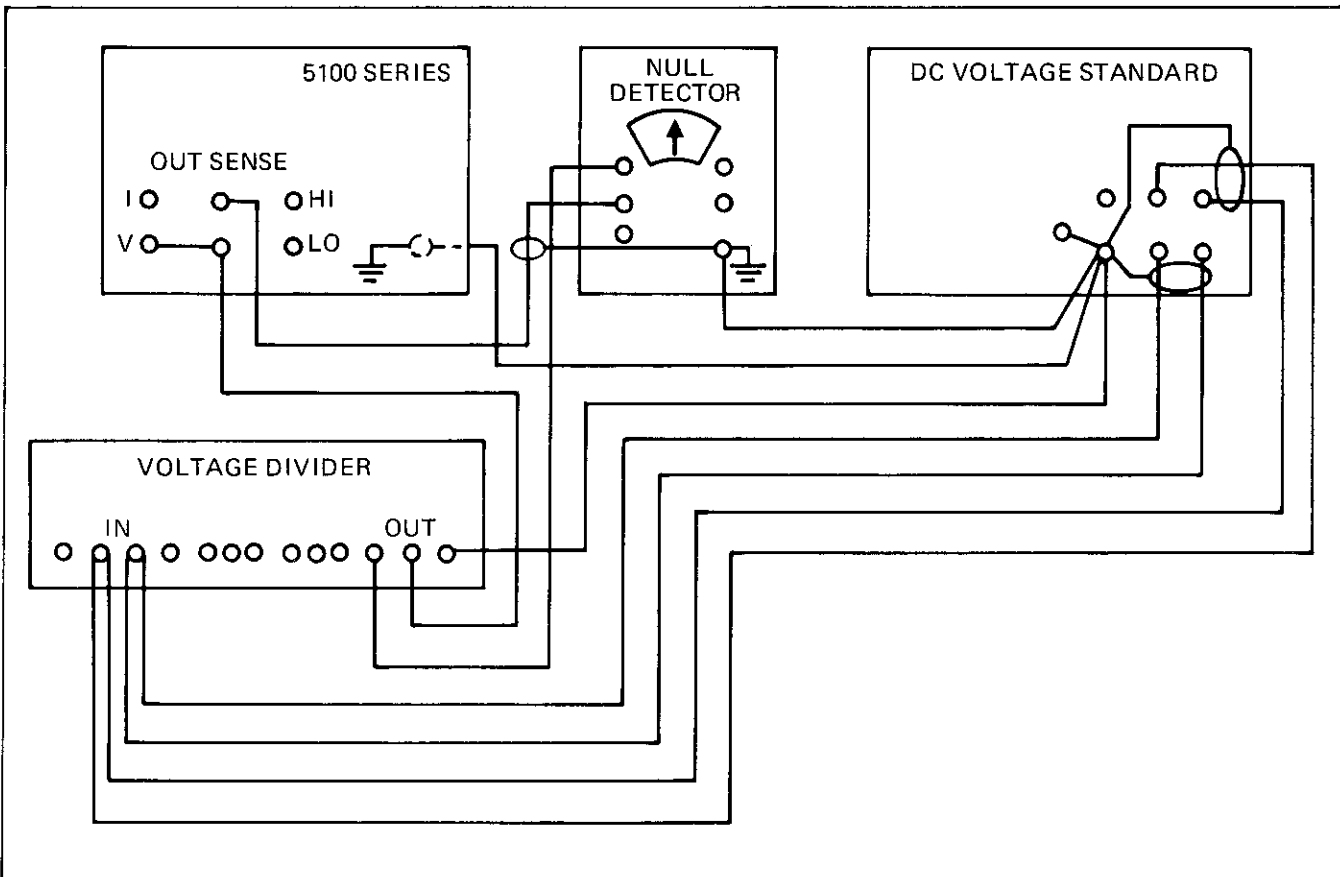

Figure 4-4. DC Low Voltage Tests

Table 4-3. DC Voltage Tests

STEP	5100 PROGRAMMED OUTPUT	DC VOLTAGE STANDARD OUTPUT	VOLTAGE DIVIDER RATIO	NULL DETECTOR STARTING RANGE	MAXIMUM 5100 % ERROR	TEST EQUIPMENT % ERROR †	TOTAL % OF ERROR (Sum) †	TOTAL % OF ERROR (Difference) †
1	+19.9900 mV	+1.000000	0.0199900	10 μ V	± 0.0310	± 0.0025	± 0.0335	± 0.0285
2*	-19.9900 mV	-1.000000	0.0199900	10 μ V	± 0.0310	± 0.0025	± 0.0335	± 0.0285
3	+199.900 mV	+1.000000	0.1999000	30 μ V	± 0.0085	± 0.0021	± 0.0106	± 0.0064
4	+1.99900V	+10.00000	0.1999000	300 μ V	± 0.0063	± 0.0012	± 0.0075	± 0.0051
5	+19.9900V	+19.99000		3 mV	± 0.0060	± 0.0011	± 0.0071	± 0.0049
6*	-19.9900V	-19.99000		3 mV	± 0.0060	± 0.0011	± 0.0071	± 0.0049
7	+199.900V	+199.90000		30 mV	± 0.0060	± 0.0016	± 0.0076	± 0.0044
8*	-199.900V	-199.90000		30 mV	± 0.0060	± 0.0016	± 0.0076	± 0.0044
9	+1000V	1000.000		300 mV	± 0.0070	± 0.0015	± 0.0085	± 0.0055
10*	-1000V	1000.000		300 mV	± 0.0070	± 0.0015	± 0.0085	± 0.0055

*Negative outputs from the DC Voltage Standard may be obtained by reversing the leads at the output + and - terminals.
†Read paragraphs 4-41 through 4-44, before using these columns.

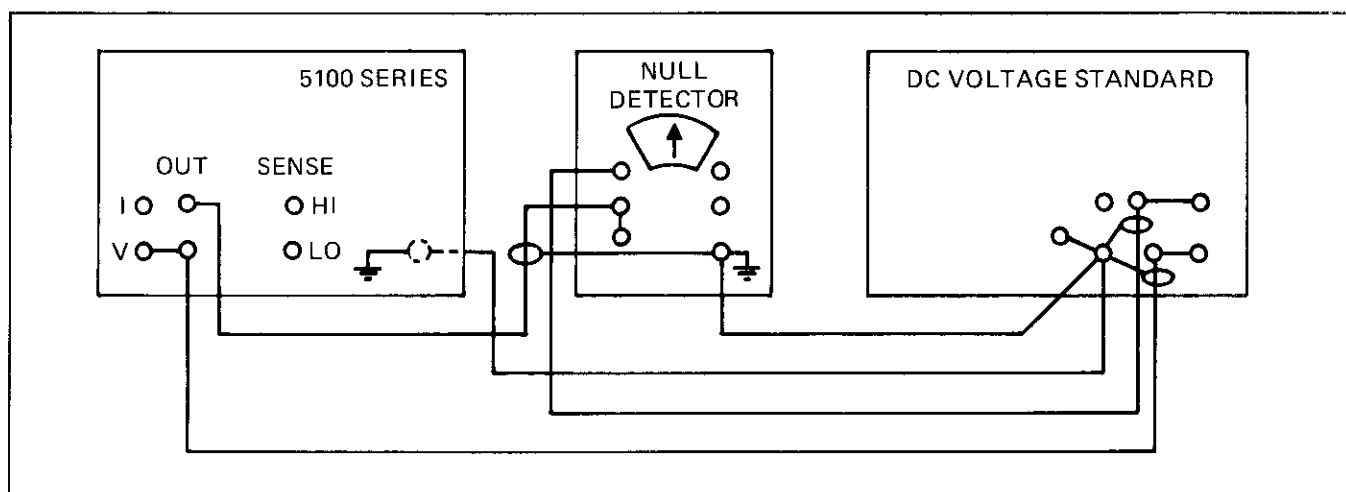

Figure 4-5. DC Voltage Tests

13. Verify the displayed error is no greater than the allowable error for the programmed calibrator output of the applicable step.

14. Select STDBY on the calibrator and test equipment.

15. Repeat steps 10 through 14 for the remaining steps of Table 4-3.

4-53. DC Ripple and Noise Tests

4-54. Perform the DC ripple and noise tests using the following procedure:

1. Insure STDBY is selected on the calibrator.
2. Construct a 10 Hz to 3 kHz bandpass filter from a 1 k Ω metal film resistor in series with a 0.05 μ F capacitor. Connect the resistor to the calibrator HI output terminal and the capacitor to the I.O terminal.
3. Connect the oscilloscope HI input to the common point on the filter's resistor and capacitor, and the LO input to the calibrator I.O terminal.

NOTE

If available, an oscilloscope plug-in filtering module with a 10 Hz to 3 Hz bandpass capability (e.g., Tektronix 5A22N) may be used.

4. Program, in turn, the DC voltage outputs in Table 4-4, applying the load, when applicable, and verify the oscilloscope display is within the listed tolerance.

NOTE

The peak-to-peak column is an approximation of the rms voltage and is not an exact equivalent.

5. When all steps in the table have been completed, select STDBY on the calibrator and remove the filter.

1. Select STDBY on the calibrator.
2. Connect the equipment as shown in Figure 4-6 using the 1.00000 kilohm shunt.

NOTE

If the actual value of the shunt is known, e.g., 1.00010 kilohms, accuracy can be improved by entering the value as a fractional-scale into the calibrator prior to programming a current output. Make the following entry: "1.00010 ENTER".

3. Select the setting in step 1 of Table 4-5 for each of the instruments listed. Insure the correct null meter polarity is selected for the programmed calibrator output.

NOTE

The DC voltage Standard, as shown in Figure 4-6, is used as a differential voltmeter in this test to obtain the added accuracy. A standard DC differential voltmeter may be substituted; however, the test equipment % of error figures in Table 4-5 must be adjusted accordingly.

4-55. DC Current Tests

4-56. Perform the DC current test using the following procedure:

Table 4-4. DC Ripple and Noise Tests

PROGRAMMED OUTPUT	APPLIED LOAD	TOLERANCE IN VOLTS RMS	ALLOWABLE % OF SETTING OF RIPPLE	APPROXIMATE PEAK-TO-PEAK
19.9999	None	0.01	2 mV	5.6 mV
20.000	None	0.05	10 mV	28 mV
20.000	2 kΩ	0.1	20 mV	56 mV
199.999	20 kΩ	0.1	.2V	0.56V
200.00	33 kΩ	0.05	.1V	0.25V

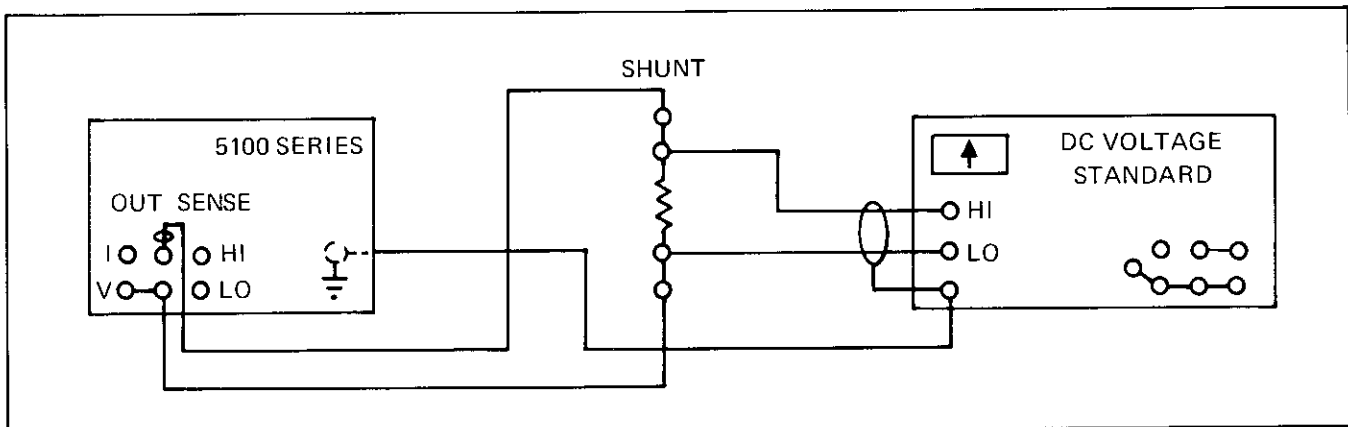

Figure 4-6. DC Current Tests

Table 4-5. DC Current Test

STEP	5100 PROGRAMMED OUTPUT	DC VOLTAGE STANDARD SETTING	MAXIMUM 5100 % ERROR	TEST EQUIPMENT % ERROR	TOTAL % OF ERROR (SUM)	TOTAL % OF ERROR (DIFFERENCE)
1	+1.90000 mA	+1.900000V	+0.028	±0.0065	±0.0345	±0.0215
2*	-1.90000 mA	+1.900000V	±0.028	±0.0065	±0.0345	±0.0215
3	+2.10000 mA	+2.100000V	±0.0493	±0.0065	±0.0559	±0.0428
4*	-2.10000 mA	+2.100000V	±0.0493	±0.0065	±0.0559	±0.0428
5	+1.00000A	+1.000000V	±0.0300	±0.0070	±0.0370	±0.0230
6*	-1.00000A	+1.000000V	±0.0300	±0.0070	±0.0370	±0.0230

*Select a negative reading on the null detector.

4. Select OPR on the calibrator.
5. Select the calibrator Error Mode and modify the calibrator output until a null is obtained on the null meter.
6. Verify the displayed error is no greater than the allowable error for the programmed calibrator output of the applicable step.
7. Select STDBY on the calibrator.
8. Repeat steps 3 through 7 for steps 2 through 4 of Table 4-5.
9. Verify all instruments are in Standby.
10. Replace the 1.00000 kilohm shunt with the 1.00000 ohm shunt, using the parallel compensation network.
11. Select the setting in step 5 of Table 4-5 for each of the instruments listed.
12. Select OPR on all instruments.

NOTE

Heat build up in the 1 ohm shunt can effect accuracy. If the test requires more than one minute, return to STDBY after that time, wait five minutes for cooling, then resume the test.

13. Select the calibrator Error Mode and modify the calibrator output until a null is obtained on the null meter.
14. Verify the displayed error is no greater than the allowable error for the programmed calibrator output of the applicable step.
15. Select STDBY on the calibrator.

16. Repeat steps 11 through 15 for step 6 of Table 4-5.

4-57. AC Voltage Tests

4-58. Perform the AC voltage tests using the following procedure:

1. Select STDBY on the calibrator.
2. Connect the equipment as shown in Figure 4-7.
3. Select the setting in step 1 of Table 4-6 for each of the instruments listed.
4. Select EXT Sensing on the calibrator.
5. Select OPR of the calibrator.
6. Perform the thermal transfer. Use the Error Mode to modify the calibrator output to obtain the null on the thermal transfer standard.
7. Verify the displayed error is no greater than the allowable error for the programmed calibrator output of the applicable step.
8. Select STDBY on the calibrator.
9. Repeat steps 3 through 8 for the remaining steps of Table 4-6.
10. Program an output of 10V dc from the DC voltage calibrator and of 10V ac at 400 Hz from the 5100 Series B Calibrator.
11. Perform the thermal transfer test. Use the Error Mode to modify the 5100 Series B Calibrator output to obtain the null on the thermal transfer standard.

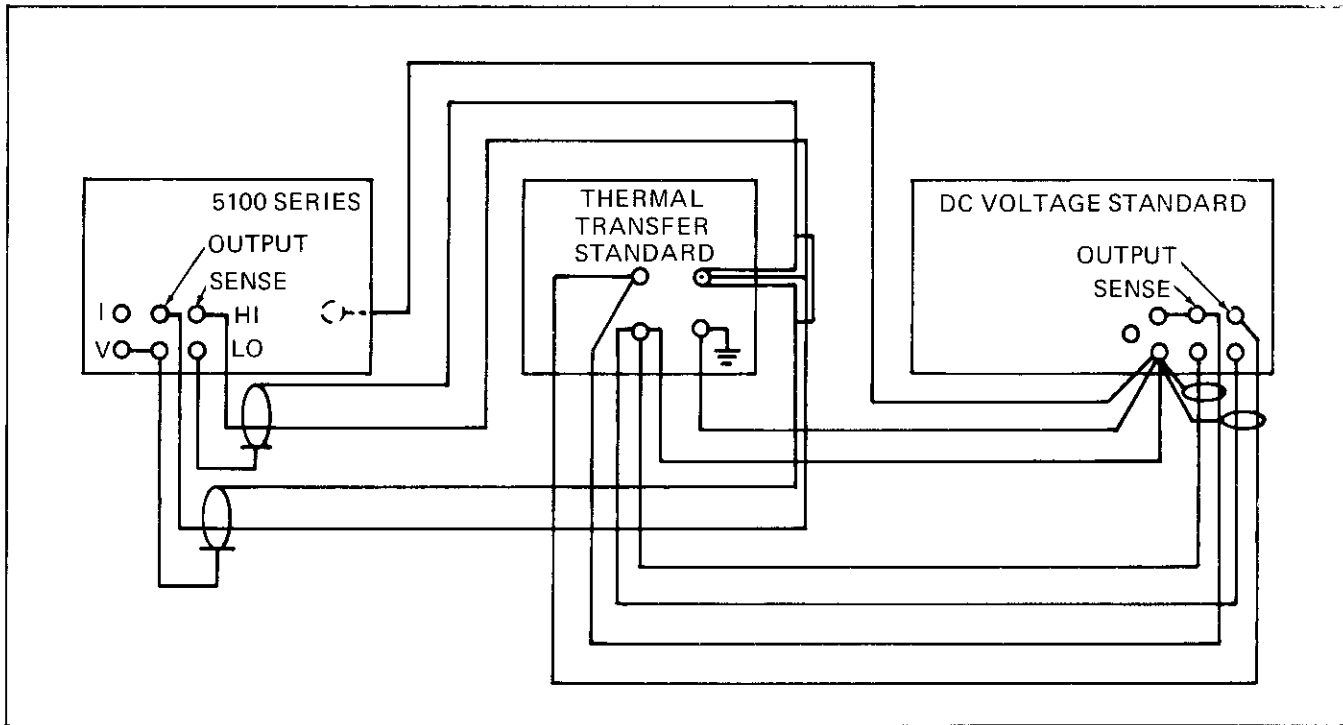

Figure 4-7. AC Voltage Tests

Table 4-6. AC Voltage Tests

STEP	PROGRAMMED 5100		DC VOLTAGE STANDARD OUTPUT	MAXIMUM 5100 % ERROR	TEST EQUIPMENT % ERROR	TOTAL % OF ERROR (Sum)	TOTAL % OF ERROR (Difference)
	VOLTAGE RMS	FREQUENCY					
1	19.9900V	400 Hz	19.99000	±0.0553	±0.0111	±0.0664	±0.0442
2	19.9900V	10 kHz	19.99000	±0.0553	±0.0111	±0.0644	±0.0442
3	19.9900V	50 kHz	19.99000	±0.0883	±0.0111	±0.0994	±0.0772
4	2.1000V	400 Hz	2.10000V	±0.1000	±0.0115	±0.1115	±0.0885
5	2.1000V	10 kHz	2.10000V	±0.1000	±0.0115	±0.1115	±0.0885
6	2.1000V	50 kHz	2.10000V	±0.1856	±0.0115	±0.1971	±0.1741
7	199.900V	1 kHz	199.9000V	±0.0550	±0.0116	±0.0666	±0.0434
8	105.000V	20 kHz	105.0000V	±0.0953	±0.0117	±0.1070	±0.0836
9	1000.00V	400 Hz	1000.000V	±0.0555	±0.0215	±0.0770	±0.0340
10	1000.00V	50 Hz	1000.000V	±0.0555	±0.0215	±0.0770	±0.0340
11	1000.00V	1 kHz	1000.000V	±0.0555	±0.0215	±0.0770	±0.0340

12. Select STDBY on the calibrators. Do not change the output settings of the 5100 Series B Calibrator.

13. Connect the equipment as shown with the solid lines in Figure 4-8.

14. Select OPR on the calibrator.

15. Set the AC ratio transformer to 0.100000, adjust the rms differential voltmeter for a null, and record the dial setting of the rms differential voltmeter.

16. Repeat step 15 with a ratio transformer setting of 0.010000 and record the rms differential voltmeter setting required to obtain a null.

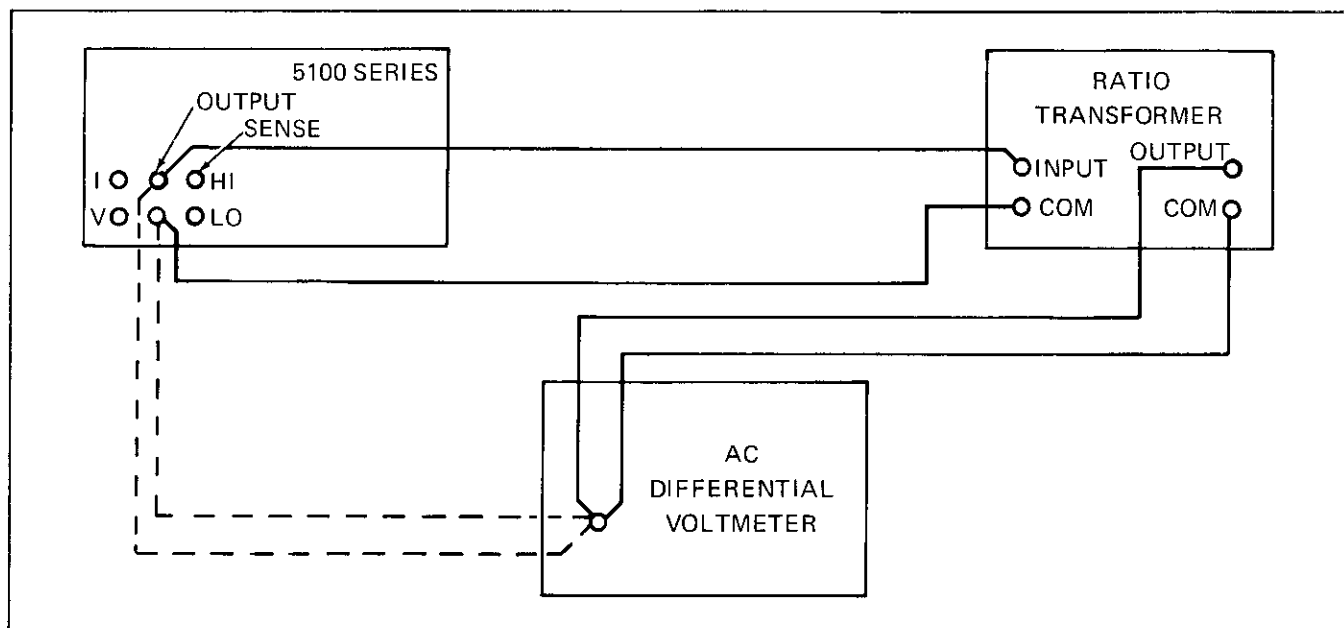

Figure 4-8. AC Low Voltage Tests

17. Repeat step 15 with a ratio transformer setting of 0.0010000 and record the rms differential voltmeter setting required to obtain a null.

18. Select STDBY on the calibrator.

19. Connect the equipment as shown with the broken line in Figure 4-8.

20. Select OPR on the calibrator.

21. Program a calibrator output of 1V ac at 400 Hz.

22. Set the rms differential voltmeter to the setting recorded in step 15 and verify the error is less than $\pm 0.065\%$.

23. Program a calibrator output of 100 mV ac at 400 Hz.

24. Set the rms differential voltmeter to the setting recorded in step 16 and verify the error is less than $\pm 0.11\%$.

25. Program a calibrator output of 10 mV ac at 400 Hz.

26. Set the rms differential voltmeter to the setting recorded in step 17 and verify the error is less than $\pm 0.56\%$.

27. Select STDBY on the calibrator.

4-59. AC Distortion and Noise Tests

4-60. Perform the AC distortion tests using the following procedure:

1. Select STDBY on the calibrator.
2. Connect the distortion analyzer to the calibrator output terminals.

NOTE

Broadband total distortion analyzers, such as the HP330 Series, may give readings above the specification limit unless used with a 200 kHz low pass filter between the calibrator output and the distortion analyzer.

3. Program an output with each voltage-frequency combination in Table 4-7 and verify the reading on the distortion analyzer does not exceed the listed tolerance.

4. When all steps in the table have been completed, select STDBY on the calibrator.

4-61. Frequency Accuracy Tests

4-62. Perform the frequency accuracy test using the following procedure:

1. Connect the calibrator output terminals to the frequency counter input.

Table 4-7. AC Distortion and Noise Tests

PROGRAMMED VOLTAGE	OUTPUT FREQUENCY	TOTAL DISTORTION AND NOISE (rms)	TOTAL DISTORTION AND NOISE %
0.3	50 Hz	0.16 mV	0.053%
0.3	1 kHz	0.16 mV	0.053%
0.3	50 kHz	0.26 mV	0.087%
10	50 kHz	8 mV	0.08%
200	1 kHz	160 mV	0.08%
200	50 Hz	160 mV	0.08%
1000	50 Hz	800 mV	0.08%

2. Program an output at each frequency in Table 4-8 at 1V rms and verify the counter reads within the frequency range listed for the programmed frequency.

Table 4-8. Frequency Accuracy Tests

CALIBRATOR FREQUENCY OUTPUT	COUNTER READING	
	MINIMUM	MAXIMUM
50 Hz	48.5 Hz	51.5 Hz
400 Hz	388 Hz	412 Hz
2 kHz	1.94 kHz	2.06 kHz
3 kHz	2.91 kHz	3.09 kHz
4 kHz	3.88 kHz	4.12 kHz
5 kHz	4.85 kHz	5.15 kHz
6 kHz	5.82 kHz	6.18 kHz
7 kHz	6.79 kHz	7.21 kHz
8 kHz	7.76 kHz	8.24 kHz
9 kHz	8.73 kHz	9.27 kHz
10 kHz	9.7 kHz	10.3 kHz
50 kHz	48.5 kHz	51.5 kHz

4-63. Resistance Tests

4-64. The ohms function of the 5100 Series B Calibrators requires two separate procedures. The first is required for the 1 ohm range, and may be used, if desired, for the 10 and 100 ohm outputs. The procedure uses the current reading stability of a constant current source and digital voltmeter to perform a transfer test. The second procedure performs a transfer for the higher ohm values from a certified standard resistor using just the 5½ digit DMM, provided it has a resolution of 1 Mohm. The second procedure is used for outputs of 1 kohm or higher,

and for the 10 and 100 ohm outputs, if they were not checked with the first procedure.

NOTE

Do not use a Kelvin bridge in lieu of the DMM for the following test. Erroneous readings will result for values ≤ 1 k Ω .

4-65. CURRENT SOURCE TRANSFER TEST

CAUTION

Set voltage limit controls on the current source to the lowest voltage possible while still providing the current required for the test. In addition, to prevent damage to the equipment, set the current source to STDBY before either setting the 5100 Series B Calibrator to STDBY or disconnecting the leads between the instruments.

1. Connect the equipment as shown in Figure 4-9.
2. Program a calibrator output of 1 ohm with EXT sensing selected and select DC volts on the DMM.
3. Multiply the certified value of the 1 ohm standard resistor by 0.1 and record the results as volts, e.g., a 1 ohm standard resistor certified at a -100 ppm error would be 0.999900 X 0.1, equaling 0.0999900, or 99.99 mV.
4. Adjust the output of the current source (approximately 100 mA) until the DMM reads the computed value.
5. Transfer the DMM leads from the standard resistor to the calibrator sense terminals.
6. Verify the DMM reads between 0.09998 and 0.10002 volts (99.98-100.02 mV), i.e., 0.10000 $\pm 0.02\%$.

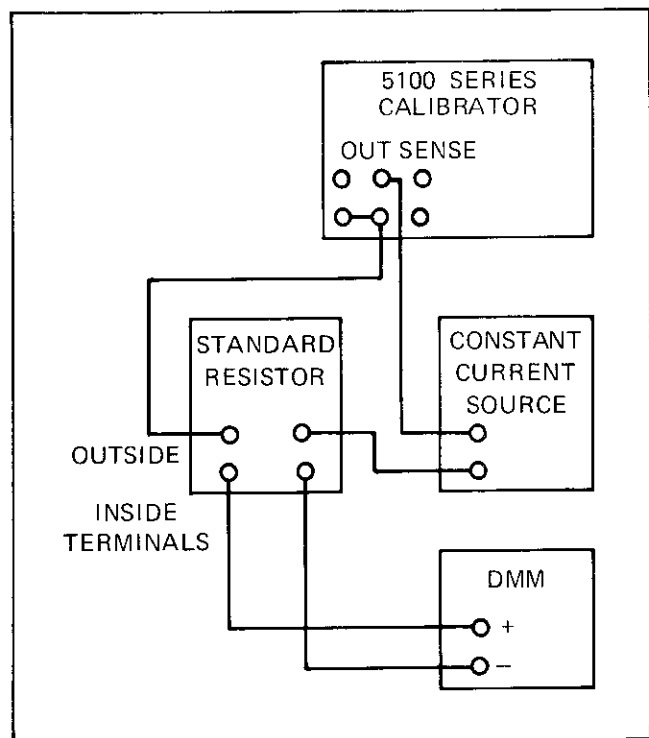

Figure 4-9. Current Source Transfer Connections

7. If the current source transfer test is used for the 10 and 100 ohm test, repeat steps 2 through 6, using calibrator settings of 10 and 100 ohms, current source setting of approximately 10 mA and 1 mA, and reading of $1.00000 \pm 0.01\%$ and $10.0000 \pm 0.005\%$, respectively.

4-66. RESISTANCE TRANSFER TEST

1. Algebraically subtract the nominal value of the standard resistor (e.g., 10 ohm, 100 ohm, etc) from the certified value of the standard resistor. Record the computed difference. A computation example is shown in Figure 4-10, using 1 ohm as an example.
2. Connect the $5\frac{1}{2}$ digit test DMM to the 10 ohm standard resistor, using the four-terminal configuration.
3. Measure the resistance of the standard resistor with the test DMM and record the value displayed.
4. Transfer the test DMM input leads from the standard resistor to the calibrator output terminals.
5. Program a calibrator output of 10 ohm, with EXT sensing selected.
6. Algebraically subtract the value recorded in step 1 from the value recorded in step 3 and verify the displayed value, when compared to the computed difference is within the resistance and tolerance listed in Table 4-9.

	CERTIFIED VALUE GREATER THAN NOMINAL	CERTIFIED VALUE LESS THAN NOMINAL
Step 1:		
Nominal Value	+1.000000	+1.000000
Certified Value	+1.000033	+0.999977
Computation:		
Change sign & add	(-) #1.000000	(-) #1.000000
Difference	+0.000033	-0.000023
Step 3:		
Measured Value	+1.00005	+0.99995
Step 6:		
Recorded Step 1	+0.000033	-0.000023
Recorded Step 3	+1.00005	+0.99995
Computation:		
Change sign & add	(-) #0.000033	(-) #0.000023
Difference	+1.000017	+0.999973
Rounded	+1.00002	+0.99997

Figure 4-10. Resistance Computation Examples

Table 4-9. Resistance Tests

RESISTANCE	TOLERANCE
10 Ω	± 1 m Ω
100 Ω	± 5 m Ω
1 k Ω	± 50 m Ω
10 k Ω	± 500 m Ω
100 k Ω	$\pm 5\Omega$
1 M Ω	$\pm 100\Omega$
10 M Ω	± 5 k Ω

7. Repeat steps 1 through 6 for the remaining calibrator resistance outputs, insuring the deviation from the computed value is within the tolerance listed in Table 4-9.

NOTE

The test DMM may be left in the four-terminal configuration for the 100k, 1M, and 10M readings, if desired; however, the actual reading will be based on two-terminal operation.

4-67. AC Current Tests

- 4-68. The accuracy of the alternating current networks was verified with the direct current tests, however, the

following tests are included to verify the proper operation of the AC relays required within the circuit. In all cases, the tolerances of the calibrator far exceed the DMM specification and the test must be considered an operational test rather than an accuracy test.

4-69. Verify the AC current operation with the following procedure:

1. Connect a DMM to the calibrator output terminals and prepare it to read alternating current.
2. Program a 190 μ A, 400 Hz output from the calibrator.
3. The DMM reads between 187 μ A and 193 μ A.
4. Program a 1.9 mA, 400 Hz output from the calibrator.
5. The DMM reads between 1.88 mA and 1.92 mA.
6. Program a 19 mA, 400 Hz output from the calibrator.
7. The DMM reads between 18.9 mA and 19.1 mA.
8. Program a 190 mA, 400 Hz output from the calibrator.
9. The DMM reads between 189 mA and 191 mA.
10. Program a 1.9 mA, 400 Hz output from the calibrator.
11. The DMM reads between 1.89 mA and 1.91 mA.

4-70. Overload Tests

4-71. These tests check the capability of the instrument to detect and react to an overload condition. The overload signal is the symbol "O.L." on the Central Display.

4-72. Perform the overload tests using the following procedure:

1. Verify the calibrator is in Standby.
2. Connect the 100 ohm, $\frac{1}{2}$ W load to the calibrator output terminals.
3. Select a 70.000 mA, 400 Hz output from the calibrator.

4. Select OPR on the calibrator.
5. The calibrator does not go into overload.
6. Remove the load from the calibrator.
7. The Central Display shows the symbol "O.L." After a delay of approximately two seconds, the calibrator automatically drops into Standby.
8. Connect the 1 ohm, 5W load to the calibrator output terminals.
9. Select a 1.40000A, 400 Hz output from the calibrator.
10. Repeat steps 4 through 8 for the 1 ohm load.

4-73. Storage System Test (Storage Only)

4-74. Operation of the storage system may be verified by loading the storage memory with random instructions, transferring the data loaded in the memory to the tape, and reading the tape back to the instrument, using the applicable operating instructions given in Section 2 of this manual.

CAUTION

As a safety precaution, none of the random instructions should exceed 30 volts in value.

4-75. The calibration procedure requires a tape loaded with 64 instructions. The data in each instruction is irrelevant as long as each available instruction slot of the 64 available is used. The tape created during the verification test may be set aside for use during the calibration, provided all 64 instruction slots were used.

CAUTION

Tapes used must be certified digital mini-cassettes that conform with ANSI Standard X3B35/77-49. Audio quality tapes will not give acceptable results.

4-76. CALIBRATION PROCEDURE

4-77. Introduction

4-78. The normal calibration interval for the 5100 Series B Calibrator is 180 days, however, the instrument should be recalibrated any time repairs are made regardless of the time since the last calibration. The ambient temperature should be between 22 and 24 degrees Celsius, with the relative humidity less than 85%. Refer to Table 4-2 for the test equipment recommended for use during calibration. Verify the instrument is set to operate at the local input

line voltage using the procedure given earlier in this section. The calibrator should have a warmup of at least 1-hour before starting the calibration procedure.

4-79. Test points and adjustments for all assemblies except the Power Supply Regulator (R83 only) and the Power Amplifier are accessible along the top edge of the applicable pcb assembly. Since there is an air space between the Power Amplifier and the Extended High Voltage assemblies, the power amp test points are accessible, however, they may be more easily accessed if the connections are made with the assembly partially withdrawn from the instrument. When a test point is called out in the procedure, turn power OFF, remove the assembly, attach the test equipment to the applicable test points, insert the assembly, and turn power ON. An optional extender pcb is available as an accessory if this alternative is desired. Adjustments and test points are listed by their reference designator, followed by the reference designator, in parentheses, of the pcb assembly on which it is located; e.g., R84 (A9), TP21 (A17), C14 (A18); which are R84 on the Power Supply Regulator, Test Point 21 on the Power Amplifier, and C14 on the Oscillator, respectively. The assemblies containing calibration adjustments and their reference designators are listed in Table 4-10.

Table 4-10. PCB Reference Designators

REFERENCE DESIGNATOR	NOMENCLATURE
A9	Power Supply Regulator
A11	Ranging Assembly
A14	Analog Control Assembly
A15	DAC Assembly
A16	Extended High Voltage Assembly
A17	Power Amplifier Assembly
A18	Oscillator Assembly

4-80. The instrument should be placed in STDBY (standby) prior to connecting or transferring any test leads and returned to OPR (operate) as the last step in the sequence when programming an output.

4-81. Power Supply Calibration

4-82. Calibrate the Power Supply Regulator using the following procedure. For non-adjustable voltages outside their tolerance, refer to the troubleshooting portion of this section.

1. Connect the test DMM to the test points listed in the first step of Table 4-11.

2. Apply power to the calibrator.
3. Adjust the voltage for the listed tolerance with the adjustment listed.
4. Repeat step 3 for the remaining steps of Table 4-11. If no adjustment is listed, verify the voltage is between the listed tolerances.

Table 4-11. Power Supply Regulator Adjustments

TEST LEADS		VOLTAGE READING		ADJUSTMENT
HI	LO	LO	HI	
TP17	TP18	+4.9	+5.3	R83
TP16	TP18	+11.25	+12.75	None
TP15	TP18	-12.75	-11.25	None
TP14	TP13	+14.99	+15.01	R6
TP12	TP13	-15.15	-14.85	None
TP12	TP1	+4.9	+5.3	R84
TP4	TP6	+60.0	+64.0	None
TP2	TP6	-64.0	-60.0	None
TP3	TP6	+37.5	+40.5	None
TP5	TP6	-40.5	-37.5	None
TP11	TP10	+14.25	+15.75	None
TP7	TP10	-15.75	-14.25	None
TP8	TP9	+4.75	+5.25	None

4-83. Power Amplifier (A17) Calibration

4-84. Calibration of the Power Amplifier requires adjustments for loop gain, zero, and bias. Prior to beginning the procedure below, prepare the instrument using the applicable procedure described in the introduction, then reapply power. Perform the Power Amp calibration using the following procedure:

NOTE

Connect the test leads to the Power Amp test points using one of the three procedures described in the Calibration Procedure Introduction. Since some of the test points called out are located on other assemblies, verify the assembly location prior to connecting test equipment.

4-85. LOOP GAIN CALIBRATION

1. Connect a test DVM, prepared for approximately 10V dc, high input lead to TP24 (A17) and the low lead to TP29 (A17).
2. Program the calibrator for an output of 1.99999V ac at 50 kHz.

3. Adjust R17 (A17) for a reading between 9.50 and 10.50V dc.

4-86. ZERO CALIBRATION

NOTE

In the remaining portion of the Power Amp Calibration, the DC meter used must make a zero measurement in the presence of up to 35V rms normal mode AC signal. This requires excellent normal mode rejection. In addition to the Fluke 885A Differential Voltmeter called out, a Fluke 845AB Null Detector, a Fluke 8020A DMM, or equivalent differential voltmeter may be used.

1. Connect the DC differential voltmeter high input lead to TP4 (A17) and the low to TP23 (A17).
2. Program the calibrator for an output of +190V dc.
3. Select OPR on the calibrator.
4. Adjust R114 (A17) for a reading of 0 ± 0.5 mV dc.
5. Program the calibrator for an output of 190V ac at 400 Hz.
6. Select OPR on the calibrator.
7. Adjust R40 (A18) for a reading of 0 ± 0.5 mV dc.
8. Transfer the DC differential high lead to TP21 (A17), or if more convenient, to TP5 (A16).
9. Adjust R155 (A17) for a reading of 0 ± 0.5 mV dc.
10. Program STDBY on the calibrator.
11. Connect a 33 ohm, 2W load to the calibrator output terminals.
12. Program the calibrator for an output of 199 mA at 400 Hz.
13. Select OPR on the calibrator.
14. Adjust R150 (A17) for a reading 0 ± 0.5 mV dc.
15. Program STDBY on the calibrator.
16. Connect a 0.5 ohm, 4W load to the calibrator output terminals.

NOTE

The load must be stable and the connections tight.

17. Program the calibrator for an output of 1.999A at 400 Hz.
18. Select OPR on the calibrator.
19. Adjust R193 (A17) for a reading of 0 ± 0.5 mV dc.
20. Program STDBY on the calibrator.
21. Remove the 0.5 ohm load from the output terminals.

4-87. BIAS CALIBRATION

1. Transfer the DC differential high input lead to TP3 (A17) and the low to TP5 (A17).
2. Program the calibrator for an output of 190V ac at 400 Hz.
3. Adjust R123 (A17) for a reading between 99.0 and 101.0 mV dc.
4. Program the calibrator for an output of 25V ac at 400 Hz.
5. Transfer the DC differential high input lead to TP8 (A17) and the low to TP9 (A17).
6. Adjust R165 (A17) for a reading between 44.9 and 45.1 mV dc.
7. Program STDBY on the calibrator.
8. Connect 0.5 ohm, 4W load to the calibrator output terminals.
9. Transfer the test DMM high input lead to TP18 (A17) and the low to TP19 (A17).
10. Program the calibrator for an output of 200 mA at 400 Hz.
11. Adjust R203 (A17) for a reading between 17.9 and 18.1 mV dc.
12. Program STDBY on the calibrator.
13. Remove the 0.5 ohm load from the output terminals.
14. If the Power Amp Assembly is installed on an extender PCB, remove power from the instrument.

remove the assembly and extender PCB, insert the assembly into the motherboard and reapply power to the instrument.

15. Install the top inner guard cover on the instrument.

4-88. OSCILLATOR (A18) CALIBRATION

4-89. Calibrate the Oscillator Assembly using the following procedure:

1. Connect the probe tip of one channel of a dual trace oscilloscope to TP3 (A18) and ground to TP10 (A18) to monitor oscillation.

2. Connect the probe of the second channel to TP2 (A18) and ground to TP10 (A18). Set the scope controls for 1V dc, 1 ms/cm, DC coupling, and use a 10:1 probe.

3. Connect a test DMM, prepared for 2V ac, high input lead to TP3 (A18) and the low to TP10 (A18).

4. Connect a frequency counter to the instrument output terminals (wideband connector if the Wideband Option is installed).

5. Program an output of 1V ac at 1 kHz with WIDEBAND selected, if the option is installed.

6. If no oscillation is present at first channel of the scope, adjust R1 (A18) until oscillation begins.

7. Program a 50 Hz output (10 Hz if the wideband option is installed).

8. Adjust R1 (A18) so the positive peaks of the waveform at TP2 (A18) are at the DC zero level (between the 0V dc and -0.5V dc level).

9. Program a 50 kHz output (90 kHz if the Wideband Option is installed).

10. Adjust C14 (A18) and C21 (A18) equal amounts in the same direction for a counter reading of 50 ± 0.1 kHz (90 ± 0.1 kHz with the Wideband Option installed).

11. Record the DMM reading at the completion of the frequency adjustment, then transfer the DMM high input lead to TP5 (A18) from TP3 (A18).

12. Adjust C14 (A18) and C21 (A18) equal amounts in opposite directions until the same DMM reading $\pm 0.05V$ rms is obtained as recorded in the step above.

13. Repeat steps 10, 11, and 12 until the two readings are within the stated tolerance without further adjustments.

14. With 50 kHz (90 kHz) programmed, note the DC level of the signal on the oscilloscope at TP2 (A18).

15. Program the calibrator output frequency of 20 kHz and note the DC level of the signal at TP2 (A18).

16. Adjust R50 (A18) for a minimum difference in the displayed DC level at the two frequencies. Reprogram the frequencies, as required, to obtain the minimum difference in DC levels.

4-90. Reference Voltage Calibration

4-91. The Analog Control Assembly (A14) reference voltage is set using the DC voltage standard, null detector as a differential voltmeter (Figure 4-11). Perform the reference voltage calibration using the following procedure:

	CERTIFIED VALUE GREATER THAN NOMINAL	CERTIFIED VALUE LESS THAN NOMINAL
Step 7:		
Nominal Value	+1.000000	+1.000000
Certified Value	+1.000033	+0.999977
Computation:	+1.000033	+0.999977
Change sign & add	(-) #1.000000	(-) #1.000000
Difference	+0.000033	-0.000023
Step 9:		
Measured Value	+1.00005	+0.99995
Step 12:		
Recorded Step 1	+0.000033	-0.000023
Recorded Step 3	+1.00005	+0.99995
Computation:	+1.000050	+0.999950
Change sign & add	(-) #0.000033	(+) #0.000023
Difference	+1.000017	+0.999973
Rounded	+1.00002	+0.99997

Figure 4-11. Calibration Resistance Computation Examples

1. Prepare the DC voltage standard, null detector for use as a differential voltmeter at +10.0005V dc.
2. Connect TP1 (A14) to the null detector input HI and TP3 (A14) to input LO.

3. Adjust R11 (A14) for a null of $0 \pm 50 \mu\text{V}$ dc.
4. Remove the connection between TP1 (A14) and the input HI terminal, at TP1.
5. Prepare the DC voltage standard; null detector for use as a differential voltmeter at 10.0005V dc.
6. Connect TP4 (A14) to the input HI terminal.
7. Adjust R23 (A14) for a null of $0 \pm 50 \mu\text{V}$ dc.
8. Remove the test equipment from the Analog Control PCB.

4-92. Low Range Ohms Calibration

4-93. The low ohms calibration is performed by relying on the short term stability of a test DMM and using it as a transfer device. The accuracy is not critical as long as the short term stability is present, but the DMM must have a resolution of $10 \mu\Omega$. Perform the low ohms calibration using the following procedure:

1. Connect the equipment as shown in Figure 4-9.
2. Program a calibrator output of 1 ohm with EXT sensing selected and select DC volts on the DMM.
3. Multiply the certified value of the 1 ohm standard resistor by 0.1 and record the result as volts (see Resistance Performance Test for example).
4. Adjust the output of the current source (approximately 100 mA) until the DMM reads the computed value.
5. Transfer the DMM leads from the standard resistor to the calibrator sense terminals.
6. Adjust R2 (A11) for a DMM reading between 0.09999 and 0.10001V dc.
7. Algebraically subtract the nominal value of the standard resistor (e.g., 10 ohm, 100 ohm, etc.) from the certified value of the standard resistor. Record the computed difference. Computation examples are shown in Figure 4-11.
8. Connect the $5\frac{1}{2}$ digit test DMM to the 1 ohm standard resistor, using the four-terminal configuration.

NOTE

Do not use a Kelvin bridge in lieu of the DMM. Erroneous readings will result for values $\leq k\Omega$.

9. Measure the resistance of standard resistor with the test DMM and record the value displayed.

10. Transfer the test DMM input leads from the standard resistor to the calibrator output terminals.

11. Program a calibrator output of 10 ohm, with EXT sensing selected.

12. Algebraically subtract the value recorded in step 7 from the value recorded in step 9 and adjust R5 (A11) for a test DMM display equal to the computed difference ± 1 digit.

13. Repeat steps 7 through 10 using a 100 ohm standard resistor and calibrator output, adjusting R8 (A11) to the value computed in step 12 ± 1 digit.

14. Repeat steps 7 through 10 using a 1K ohm standard resistor and calibrator output, adjusting R11 (A11) to the value computed in step 12 ± 1 digit.

15. Repeat steps 7 through 10 using a 10K ohm standard resistor and calibrator output, adjusting R14 (A11) to the value computed in step 12 ± 1 digit.

4-94. DC Zero Calibration

4-95. Set the DC zero circuits using the following procedure:

1. Connect the equipment as shown in Figure 4-12.
2. Prepare the DC voltage standard; null detector for use as a differential voltmeter at 0.000000V dc.
3. Program the calibrator for a 0V dc output with the 50 OHM OVERRIDE selected.
4. Adjust R63 (A14) for a null of $0 \pm 10 \mu\text{V}$ dc.
5. Connect an oscilloscope set to 50 mV/cm with a 10:1 probe to TP5 (A14) and ground to TP14 (A14).
6. Connect a jumper between TP13 (A14) and TP14 (A14).
7. Adjust R71 (A14) for an oscilloscope display that does not constantly drift toward the same polarity.
8. Remove the jumper connecting TP13 (A14) and TP14 (A14) and readjust R63 (A14) for a null of $0 \pm 10 \mu\text{V}$ dc, if required.

4-96. Current Gain Calibration

4-97. Perform the current gain calibration using the following procedure:

1. Connect the equipment as shown in Figure 4-6 using the 1k ohm precision shunt.

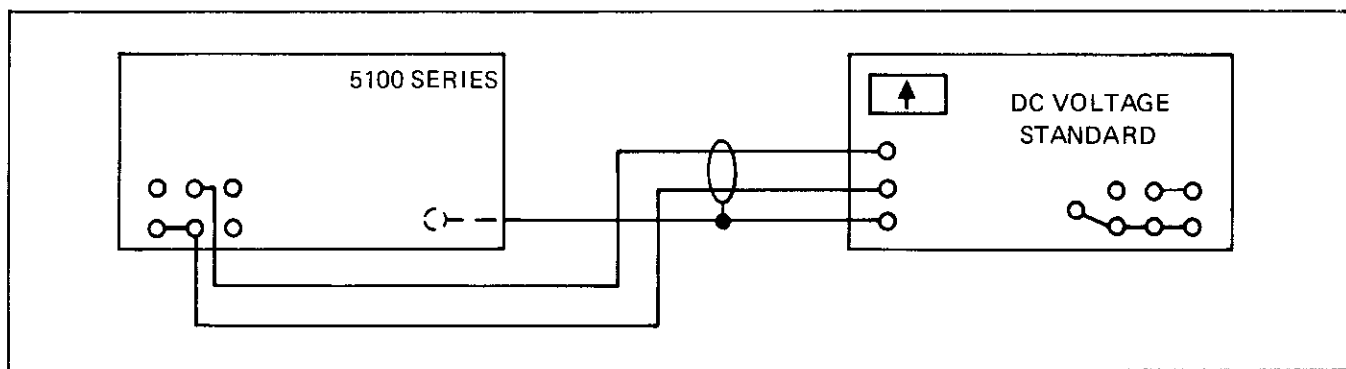

Figure 4-12. Differential Connections

2. Prepare the DC voltage standard, null detector for use as a differential voltmeter at 1.9V dc.
3. Program the calibrator for an output of 1.9 mA dc and adjust R42 (A15) for a null at $0 \pm 20 \mu\text{V}$ dc.
4. Place the calibrator and DC voltage standard in the Standby Mode.
5. Replace the 1 kilohm precision shunt with the 1 ohm precision shunt.
6. Enter 1.9A dc into the calibrator.
7. Place the calibrator and DC voltage standard in the Operate Mode.

NOTE

Heat build up in the 1 ohm shunt can effect accuracy. If the test requires more than one minute return to STDBY after that time, wait five minutes for cooling, then resume the test.

8. Check for a null of $0 \pm 285 \mu\text{V}$ (0.015%) on the voltage standard (differential).
9. If the reading is within tolerance proceed to the next procedure. If it is out of tolerance, perform the remainder of the subparagraph.
10. Adjust R2 (A11) for a null of $0 \pm 285 \mu\text{V}$.
11. Repeat the R2 (A11) adjustment of the Low Range Ohms Calibration (steps 1 through 6) and adjust, if required, for the listed tolerance.
12. Repeat steps 10 and 11 until both readings are within tolerance.

NOTE

Since R2 (A11) is part off the divider networks for both the 1 ohms and 1 amp ranges, it must be adjusted to meet both requirements. If this cannot be accomplished the circuit requires troubleshooting to define the problem.

4-98. High Range Ohms Calibration

4-99. Portions of the high range calibration require the computation of a resistance value prior to making an adjustment. The computation is based on the nominal value of a standard resistor (e.g., 1 kohm 100 kohm, etc.) and the certified value of the same standard resistor (Figure 4-10). Use the following procedure to obtain this value.

1. Algebraically subtract the nominal value of the standard resistor (e.g., 1 k Ω , 100 k Ω , etc.) from the certified value of the standard resistor. Record the computed difference. Connect the equipment using the four-terminal configuration.
2. Connect the 5½ digit test DMM to the standard resistor in use.
3. Measure the resistance of the standard resistor with the test DMM and record the value displayed.
4. Transfer the test DMM input leads from the standard resistor to the designated test points or terminals.
5. Program the designated calibrator output, with EXT sensing selected.
6. Algebraically subtract the value recorded in step 1 from the value recorded in step 3 and adjust the designated point for a test DMM display equal to the computed difference \pm the stated tolerance.

4-100. Perform the high range ohms calibration using the following procedure:

1. Perform steps 1 through 4 of the resistance procedure above using a 1 k Ω standard resistor.
2. Program a 100 k Ω calibrator output.

NOTE

The test is made with a 1 k Ω standard resistor while the calibrator is programmed for 100 k Ω to set the lower portion of the high ohm and voltage ranging ladder.

3. Perform step 6 of the resistance procedure above, connecting the test DMM HI to TP8 (A11) and the LO to TP9 (A11) and adjusting R38 (A11) for the computed value ± 1 digit.

NOTE

The remaining resistance measurements may be performed in the four-terminal configuration if desired; however, the instrument automatically selects internal sensing.

4. Perform the resistance procedure above, using 100 k Ω , connecting the test DMM to the calibrator output terminals and adjusting R30 (A11) and R33 (A11) equal amounts in the same direction for the computed value in step 6 ± 1 digit.

5. Connect the equipment as shown in Figure 4-12.

6. Prepare the DC voltage standard, null detector for use as a differential voltmeter at 19.00000V dc.

7. Program the calibrator for an output of 19V dc.

8. Adjust R30 (A11) and R33 (A11) equal amounts in opposite directions for a null at $0 \pm 190 \mu\text{V}$ dc.

9. Prepare the DC voltage standard, null detector for use as a differential voltmeter at 190.0000V dc.

10. Program the calibrator for an output of 190V dc.

11. Adjust R27 (A11) for a null of 0 ± 1.9 mV dc.

12. Prepare the DC voltage standard, null detector for use as a differential voltmeter at 1000.0000V dc.

13. Program the calibrator for an output of 1000V dc.

14. Adjust R37 (A11) for a null of 0 ± 10 mV dc.

15. Repeat steps 4 through 16 until all measurements are within tolerance without an adjustment.

16. Perform the resistance procedure above using 1 M Ω , connecting the test DMM to the calibrator output terminals and checking for the computed value ± 40 ohms. There is no adjustment for this step; however, if the error is not gross it may be brought within tolerance by restarting the

procedure at step 1. If the reading is still out of tolerance after repeating the procedure, troubleshoot the circuit.

17. Perform the resistance procedure above using 10 M Ω , connect the test DMM to the calibrator output terminals, and adjusting R22 (A11) for the computed value ± 400 ohms.

4-101. Millivolt Range Calibration

4-102. Perform the millivolt range calibration using the following procedure:

1. Connect the equipment as shown in Figure 4-4. Do not use the null detector built into the DC voltage standard.

2. Set the voltage divider ratio to .19.

3. Prepare the dc voltage standard, null detector for an output of +10.000000V dc.

4. Program the calibrator for an output of 1.9V dc.

5. Adjust R19 (A11) for a null of $0 \pm 19 \mu\text{V}$ dc.

6. Reverse the leads at the DC voltage standard output terminals to obtain a negative output.

7. Program the calibrator for an output of 1.9V dc.

8. Adjust R19 (A11) to balance the null error of the $\pm 1.9\text{V}$ dc inputs.

9. Repeat steps 3 through 8 until the error is balanced (the same at both plus and minus 1.9V dc) and within the listed tolerances.

10. Set the voltage divider to .0190000 and repeat the procedure in steps 3 through 8, using R16 (A11) to obtain a balance for the $\pm 190 \mu\text{V}$ dc input with a tolerance of $\pm 5 \mu\text{V}$ dc.

11. Set the voltage divider to .0019000 and repeat the procedure in steps 3 through 8, using R55 (A11) to obtain a balance for the 19 mV dc input with a tolerance of $\pm 5 \mu\text{V}$ dc.

4-103. AC Calibration

4-104. Perform the AC Calibration using the following procedure:

1. Connect the equipment as shown in Figure 4-7.

2. Set the thermal transfer standard to the 2 volt range.
3. Set the DC Voltage Standard controls for an output of 2.000000V dc.
4. Program the calibrator for an EXT sensed output of 2V ac at 1 kHz.
5. Perform the thermal transfer, adjusting R39 (A14) for a null $\pm 0.01\%$.
6. Set the thermal transfer standard to the 20 volt range.
7. Set the DC Voltage Standard controls for an output of 19.9999V dc.
8. Program the calibrator for an output of 19.999V dc at 1 kHz.
9. Perform the thermal transfer, adjusting R32 (A14) for a null $\pm 0.005\%$.
10. Repeat steps 3 through 9 until both tests are within tolerance without an adjustment.
11. Program the calibrator for an output of 19.9999V ac at 50 kHz.
12. Perform the thermal transfer, adjusting C15 (A11) for a null $\pm 0.01\%$.
13. Set the thermal transfer standard to the 100 volt range.
14. Set the DC Voltage Standard controls for an output of 100.0000V dc.
15. Program the calibrator for an output of 100V ac at 20 kHz.
16. Perform the thermal transfer, adjusting C1 (A11) for a null $\pm 0.01\%$.

4-105. Storage System Calibration (Storage Only)

4-106. Calibrate the storage system using the following procedure:

CAUTION

Tapes used must be certified digital mini-cassettes that conform with ANSI Standard X3B5/77-49. Audio quality tapes will not give acceptable results.

1. Select STDBY on the calibrator.
2. Connect a frequency counter between TP2 (A8) (HI) and TP1 (A8) (LO).
3. Adjust R2 (A8) for a reading on the frequency counter between 9.55 kHz and 9.65 kHz.
4. Place a prepared tape with data loaded into all 64 addresses into the tape reader.

NOTE

The prepared tape must have all 64 address locations filled; however, the data is immaterial. For example, all 64 locations could be filled with the same instruction, i.e., 1V dc or 100 mV, 400 Hz or 100Ω.

5. Disconnect the frequency counter and connect an oscilloscope between TP3 (A8) (HI) and TP1 (A8) (LO). Set the scope to read 50 μ s/cm.
6. Select STORAGE ENABLE, TAPE, and READ (STORE indicator extinguished) on the calibrator.
7. When the tape begins to run forward, adjust R13 (A8) for a waveform high period between 295 and 305 μ s.
8. Select STORAGE and TAPE disable, and disconnect the test equipment.

4-107. Factory Selected Component Replacement

4-108. Some components are factory selected at the time of manufacture. None are high failure items; however, if replacement is required, use the applicable portion of the following procedure, or return the assembly to your local Fluke Service Center. Failure to use the correct replacement procedure may affect the calibration of the instrument. The instrument should be recalibrated any time that one of the following component selection procedures is used.

4-109. ANALOG CONTROL ASSEMBLY - R64 R66

4-110. Either R64 or R66 will be installed in the instrument with a jumper wire installed in the other position. If the installed resistor fails, use the following procedure to replace the resistor wire combination:

1. With power removed from the instrument and the Analog Control Assembly removed, replace the defective resistor with a jumper so that both the R64 and R66 positions are jumpered.

2. Replace the assembly and apply power to the instrument.
3. Place a test DMM across the output terminals, high to high and low to low.
4. Program a calibrator output of 0V with 50Ω OVERRIDE selected.
5. If the DMM reading is positive, remove power and the assembly, then replace the jumper in the R66 position with a decade box. If the reading is negative, replace the R64 jumper with the decade box.
6. Restore the assembly and power, then adjust the decade box for a DMM reading of $0.0 \pm 5 \mu\text{V}$.
7. Replace the decade box with a resistor the value of the decade box setting $\pm 3\%$. Determine the actual value of the decade box setting with the $5\frac{1}{2}$ digit test DMM. Use a T9 type, metal film, 1%, 1.8 watt resistor to replace the jumper wire.

4-111. ANALOG CONTROL ASSEMBLY R13, R14

4-112. The resistance value of R13 and R14 in the analog control regulator circuit is critical to the accuracy of the output. If either component fails or the regulator (U10) is replaced, new values should be selected using the following procedure:

1. Remove R13 (A14) and R14 (A14) from the circuit and temporarily replace them with a 20-turn, 1 kΩ, $\frac{1}{2}$ watt potentiometer (Fluke Stock No. 267856).
2. Connect the $5\frac{1}{2}$ digit test DMM between TP1 (A14) HI and TP3 (A14) LO.
3. Apply power to the instrument, allow it to warmup, then adjust the 1 kΩ potentiometer, installed in step 1, for a DMM reading of +10.005V dc.
4. Remove power, then remove the potentiometer from the instrument, taking care not to change the potentiometer setting.
5. Measure the resistance of the potentiometer using the $5\frac{1}{2}$ digit test DMM and select the precision resistors required from Table 4-12. If the value required is less than 200 ohms, install the selected resistor in R13 and a jumper wire in R14. For value in excess of 200 ohms place the required 100's value in R13 and the 10's value in R14.

4-113. RANGING ASSEMBLY C2, C18, C20

4-114. On the Ranging Assembly, capacitors, C2, C18, and C20, are selected for high frequency performance.

Use the following procedure for component selection when required by component failure or a fault in the high frequency adjustment.

NOTE

This procedure requires a DMM certified for 20V ac at 50 kHz. Subtract, algebraically, the supplied correction factor before using the replacement table.

1. Remove any components presently installed in the C2, C18, and C20 positions.
2. Connect the test DMM to the output terminals; high to output high and low to output low.
3. Rotate C15 through its range and record the maximum and minimum readings.
4. Set C15 for a reading at the midpoint between the maximum and minimum readings.
5. Program a calibrator output of 19.9999V ac at 50 kHz.
6. Subtract, algebraically, the correction factor from the DMM reading, then install the capacitors listed for that voltage range in Table 4-13. The capacitors are dipped mica, $\pm 5\%$ tolerance, with a voltage rating of 500V dc.
7. Adjust C15 for a DMM reading of 19.9999V ac, after taking into account the correction factor.

4-115. RANGING ASSEMBLY C31, C32

4-116. Capacitor C31 or C32, or possibly neither, are installed in the Ranging Assembly to compensate for PCB variances that effect the millivolt divider. The procedure in the subsequent subparagraphs should be performed any time the installed capacitor, or any of the fixed wirewound resistors in the millivolt divider (R66, R67, R68, R69, R70, R71), are replaced. Three parts are possible for installation and the follow in the sequence; Description, Fluke Stock Number; Manufacturers Federal Supply Code, and Manufacturers Part Number:

Cap, Mica, 2 pF ± 0.5 pF, 500V; 175208; 72136; DM15C020E

Cap, Mica, 10 pF $\pm 10\%$, 500V; 175216; 72136; DM15C100K

Cap, Mica, 22 pF $\pm 5\%$, 500V; 148551; 72136; DM15C220J

Table 4-12. Divider Resistor Selection

RESISTOR VALUE	FLUKE STOCK NO.	RESISTOR VALUE	FLUKE STOCK NO.	RESISTOR VALUE	FLUKE STOCK NO.	RESISTOR VALUE	FLUKE STOCK NO.
15	215038	65	214536	114	214049	164	213546
16	215020	66	214528	115	214031	165	213538
17	215012	67	214510	116	214023	166	213520
18	215004	68	214502	117	214015	167	213512
19	214999	69	214494	118	214007	168	213504
20	214981	70	214486	119	213991	169	213496
21	214973	71	214478	120	213983	170	213488
22	214965	72	214460	121	213975	171	213470
23	214957	73	214452	122	213967	172	213462
24	214940	74	214445	123	213959	173	213454
25	214932	75	214437	124	213942	174	213447
26	214924	76	214429	125	213934	175	213439
27	214916	77	214411	126	213926	176	213421
28	214908	78	214403	127	213918	177	213413
29	214890	79	214395	128	213900	178	213405
30	214882	80	214387	129	213892	179	213397
31	214874	81	214379	130	213884	180	213389
32	214866	82	214361	131	213876	181	213371
33	214858	83	214353	132	213868	182	213363
34	214841	84	214346	133	213850	183	213355
35	214833	85	214338	134	213843	184	213348
36	214825	86	214320	135	213835	185	213330
37	214817	87	214312	136	213827	186	213322
38	214809	88	214304	137	213819	187	213314
39	214791	89	214296	138	213801	188	213306
40	214783	90	214288	139	213793	189	213298
41	214775	91	214270	140	213785	190	213280
42	214767	92	214262	141	213777	191	213272
43	214759	93	214254	142	213769	192	213264
44	214742	94	214247	143	213751	193	213256
45	214734	95	214239	144	213744	194	213249
46	214726	96	214221	145	213736	195	213231
47	214718	97	214213	146	213728	196	213223
48	214700	98	214205	147	213710	197	213215
49	214692	99	214197	148	213702	198	213207
50	214684	100	214189	149	213694	199	213199
51	214676	101	214171	150	213686	200	213181
52	214668	102	214163	151	213678	300	227686
53	214650	103	214155	152	213660	400	131698
54	214643	104	214148	153	213652	500	195388
55	214635	105	214130	154	213645	600	279711
56	214627	106	214122	155	213637	700	279703
57	214619	107	214114	156	213629	800	341701
58	214601	108	214106	157	213611	900	228742
59	214593	109	214098	158	213603	1000	131706
60	214585	110	214080	159	213595	1100	238949
61	214577	111	214072	160	213587	1200	278077
62	214569	112	214064	161	213579	1300	278069
63	214551	113	214056	162	213561	1400	278051
64	214544			163	213553		

Table 4-13. High Frequency Capacitor Selection

DMM INDICATION	C18	C2	C20	FLUKE STOCK NO.
19.900–19.953			47 pF	148536
19.954–19.999			22 pF	148551
20.000–20.068	2 pF			175208
20.069–20.096	3 pF			460436
20.097–20.124	4 pF			190397
20.125–20.152	5 pF			148577
20.153–20.180	4 pF	2 pF		190397, 175208
20.181–20.208	4 pF	3 pF		190397, 460436

1. Verify a 2 pF capacitor is installed in the C31 position and the C32 position is vacant.
2. Connect an AC differential voltmeter to the calibrator output terminals using coaxial cable.
3. Prepare the differential to read a null (1% scale minimum) at 20 mV.
4. Program a calibrator output of 19.9999 mV at 50 kHz.
5. If the reading is a null $\pm 0.29\%$ on the 1% null scale the present arrangement is correct and no further checks are needed. This is generally the case. If the null reading exceeds $+0.29\%$, perform the applicable of steps 6, 7, or 8. If the reading exceeds -0.29% go to step 10.
6. For readings greater than the null between $+0.29\%$ and $+0.45\%$, remove the 2 pF capacitor from C31 and perform step 9 with neither C31 or C32 installed.
7. For readings greater than the null between $+0.45\%$ and $+0.6\%$, remove the 2 pF capacitor from C31, install the 10 pF capacitor in C32 and perform step 9 with only C32 installed.
8. For readings greater than the null of $+0.6\%$, remove the 2 pF capacitor from C31, install the 22

pF capacitor in C32 and perform step 9 with only C32 installed.

9. Retaining the original calibrator and differential voltmeter settings, recheck for a null $\pm 0.29\%$. If the reading is within the listed tolerance the present arrangement is correct and no further checks are needed.

10. If the reading is below the bottom tolerance on the initial reading, or one pass through the selection procedure, does not bring it within tolerance the assembly is defective. Check the voltage divider circuit or return the assembly to you local Fluke service center.

4-117. TROUBLESHOOTING

4-118. Troubleshooting for the analog circuitry in the instrument is covered in the tabular flow charts beginning with Table 4-14. When a step on the flow chart is completed, check for a decision transfer. If no descision is required, perform the next step of the table in sequence.

NOTE

If any question arises during the troubleshooting procedure on a reading by a DMM, verify the signal present with an oscilloscope.

Table 4-14. Display Troubleshooting

STEP NO.	ACTION	Go to the step number given for correct response	
		YES	NO
1	Apply power to the instrument and select POWER ON.		
2	Does the Output Display read +0.0000 mV, with the STDBY, LOCAL, INT (Sense), and 50Ω DIVIDER indicators illuminated?	7	3
3	Check for voltages on the Power Supply Regulator (A9). With the DMM low at TP18, check with the high lead at TP15 for $-12 \pm 0.5V$ dc, at TP16 for $+12 \pm 0.5V$ dc and at TP17 for $+5.2 \pm 0.25V$ dc.		
4	Are all voltages present and within their listed tolerance?	6	5
5	Check out the Power Supply Regulator (A9) using the applicable table. Repair as required, then resume at step 1.		
6	Check the Controller and Memory Assemblies (A20 and A21), bus lines, and connectors. Replace or repair as required, then resume at step 1.		
	<i>NOTE</i> The following series of tests check out a section of the Front Panel indicators. If any indicators are not operational, perform the fault location subroutine, then return to the main program at the step initiating the transfer.		
7	Key -in +188.88 μA, but do not depress ENTER.		
8	Does the Central Display read +188.88 with the μA and KEYBOARD indicators illuminated?	9	58
9	Depress ENTER.		
10	Does the +188.888, μ, and A indicators transfer to the Output Display and the KEYBOARD indicator extinguish?	11	58
11	Toggle the SENSE switch.		
12	Does the EXT indicator illuminate and the INT indicator extinguish?	13	58
13	Toggle the SENSE switch again.		
14	Does the INT indicator illuminate and the EXT indicator extinguish?	15	58
15	Depress the CLEAR switch, then repeat steps 11 through 14 for the LOCAL/REM and 50Ω DIVIDER/OVERRIDE indicators.		
16	Did both operations perform correctly?	17	58
17	Toggle the RECALL switch.		
18	Does the RECALL indicator illuminate?	19	58
19	Toggle the RECALL switch again.		
20	Does the RECALL indicator extinguish?	21	58
21	Repeat steps 17 through 20 for the EXT OSC, BOOST, and WIDEBAND switches.		
22	Did all of the operations perform correctly?	23	58
23	Depress the following switches in the sequence listed: CLEAR, 1, /, 2.		
24	Does the Central Display read 1–2, with the KEYBOARD indicator illuminated?	25	58
25	Depress the following switches in the sequence listed: CLEAR, ENTRY LIMIT, 1, μ, V.		

Table 4-14. Display Troubleshooting (cont)

STEP NO.	ACTION	Go to the step number given for correct response	
		YES	NO
26	Does the Central Display read 1, with the μ , V, and LIMIT indicator illuminated?	27	58
27	Depress the following switches in the sequence listed: CLEAR, TOL LIMIT, 1, %.		
28	Does the Central Display read 1, with the LIMIT and % ERROR indicators illuminated?	29	58
29	Depress the following switches in the sequence listed: CLEAR, CLEAR, 1, K, Hz.		
30	Does the Central Display read 1, with the AC, k, Hz, and KEYBOARD indicators illuminated?	31	58
31	Depress the following switches in the sequence listed: 1, m, A, ENTER.		
32	Does the Output Display read 1.0000, with the AC, m, and A indicators illuminated and the Central Display reads 1000.0 with the AC and Hz indicators illuminated?	33	58
33	Depress the following switches in the sequence listed: -, 1, ., 1, dBm		
34	Does the Central Display read -1.1, with the Ac, dBm, and KEYBOARD indicators illuminated?	35	58
35	Depress the ENTER switch.		
36	Does the Output Display read -1.10000, with the AC and dBm indicators illuminated?	37	58
37	Depress the ERROR MODE-ENABLE switch.		
38	Does the Central Display read +0.00000 with dB ERROR and ERROR MODE indicators illuminated?	39	58
39	Depress the following switches in the sequence listed: 1, M, Ω .		
40	Does the Central Display read 1, with the M, Ω , and KEYBOARD indicators illuminated?	41	58
41	Depress the ENTER switch.		
42	Does the Output Display read 1.00000 with the M and Ω indicators illuminated and does the Central Display and indicators extinguish?	43	58
	<i>NOTE</i> <i>The D1, D2, D3, and D4 indicators are inoperative and have no function at this time.</i>		
43	Depress the following switches in the sequence listed: 2, 3, 4, 5, 6.		
44	Does the Central Display read 23456?	45	59
45	Depress the following switches in the sequence listed: CLEAR, 7, 8, 9, 1.		
46	Does the Central Display read 7891?	47	59
47	Depress the following switches in the sequence listed: m, V, ENTER, ERROR MODE ENABLE.		
48	Does the Output Display read 7.8910 with the zero intensified and illuminated? Does the Central Display read +.0000, the % ERROR and ERROR MODE indicator illuminate?	49	59
49	Depress the left DECADE switch four times.		
50	Did the intensified digit move to the left from the zero to the one, to the nine, to the eight, to the seven?	51	59
51	Depress the right DECADE switch four times.		
52	Did the intensified digit move to the right and back to zero?	53	59
53	Turn the EDIT switch knob clockwise until the Output Display reads 7.8920.		
54	Does the EDIT switch change the Output Display and the error percentage on the Central Display?	56	55

Table 4-14. Display Troubleshooting (cont)

STEP NO.	ACTION	Go to the step number given for correct response	
		YES	NO
55	For no movement, check U22-6; for periodic skips, check U26; for extra counts, check R4, R5, and R6. Repair as required, then resume at step 53.		
56	Depress the NEWREF/CAL 1Ω switch.		
57	Does the Central Display error display change to +.0000 and the % ERROR indicator remain illuminated?	60	59
58	Front Panel Indicator Subroutine. Each indicator on the Front Panel, including segments on the numerical LED assemblies, are controlled on both the anode and cathode. All anodes are connected in one-of-eight groups, each group is controlled by power transistors Q1 through Q8. U1 and U9 are latches, which in conjunction with U10, U11, and RN1 cycle the transistors Q1 through Q8 for 2 ms periods with one rest period at the ninth interval. The emitter voltage of the selected transistor should be +5 ±0.7V dc during the 2 ms period, while all other emitter voltages should be less than 2V dc. Check CR44 and U21 for incorrect voltages. Commands from the instrument Controller into latches U2 through U6 and their drivers (U7, U8, U13 through 20), apply common to the indicators. Failure of the resistors (R9, R10, R11, R12) or the resistor networks (RN3, RN4) can cause the indications under the control of that resistor to be excessively bright, dim, or not illuminate. If the problem is located, repair as required, then return to the main program at the step initiating the transfer to the subroutine. If the fault cannot be isolated to the indicator control circuits, it might be in a defective key. In this case continue with step 59.		
59	All the Front Panel key switches are wired into a seven column, eight row matrix. The instrument Controller periodically activates the columns through latches U1 and U9 and, therefore, synchronized with the power transistors, Q1 through Q8. Failure of any latch in U1 or U9 will disable a column of key switches (refer to the matrix chart on the schematic). The key switch outputs are held low by RN2 until a switch is depressed. An open resistor in RN2 can result in noise resulting in spurious data entries. A shorted resistor in RN2 disables all the switches in that row. The Controller reads switch closures on data lines ID0 through ID7. These data lines are isolated by the buffers U26 and U27 which are held disabled by RDSW high at U22-9 from the Controller. Repair as required, then return to the step in the main program that initiated the transfer.		
60	Troubleshooting of the Front Panel is now completed.		

Table 4-15. Analog Circuitry Troubleshooting

STEP NO.	ACTION	Go to the step number given for correct response	
		YES	NO
1	Remove power from the instrument, wait at least 30 seconds, and then remove the Analog Control Assembly from the instrument. Install it into an Extender Assembly and install the combination in the calibrator. Reapply power to the instrument and program an output of +1.9V dc.		
2	Check with an oscilloscope HI lead at P52; pins 14, 15, 17, 18, 19, 20, 32, 35, 36, 37, 38, 39, and 40 for a pulse train with high levels at -15V and low levels at -20V. Use TP9 (A14) or ∇_s for scope low.		
3	Is the pulse train present at all pins, at the proper levels?	5	4
4	One at a time, remove the PCB assemblies from the analog compartment until the pulse train returns to normal. When the PCB causing the problem is identified, refer to the procedures for troubleshooting that board. If all boards in the analog compartment have been removed and the trouble remains, check the buffer/drivers on the Isolator Assembly (A19). Repair as required, then resume at step 2.		
5	Connect the test 5½ digit DMM to the output terminals of the calibrator in a four-terminal ohms configuration.		
6	Program, in turn; 1, 10, 100, 1k, 10k, 100k, 1M, and 10M ohms from the calibrator. Check the outputs with the test DMM for readings of 1 ± 0.05 , 10 ± 0.1 , $1k \pm 1$, $100k \pm 50$, $1M \pm 1k$, and $10M \pm 10k$ ohms, respectively.		
7	Are all of the resistance readings within the stated tolerances?	9	8
8	Check the relay circuits and their associated logic components on the Ranging Assembly (A11). Relay K55 is applicable to all ranges; K56 to the 100k, 1M, and 10M ohm ranges only; and K4 through K10 each applicable to a single range, 1 ohm through 10M ohms, respectively. The relays are controlled by logic circuits in U3 through U8, U10 through U14, U16, and U18. Repair as required, then resume at step 5.		
9	Prepare the test DMM connected to the output terminals to read approximately 10V dc.		
10	Program a +10V dc Calibrator output and observe the display.		
11	Program a -10V dc Calibrator output and observe the display.		
12	Are both readings within 1.0 mV of the programmed outputs?	28	13
13	Connect the DMM between TP5 (High) and TP8 (Low) on the Analog Control PCB and program the first incorrect voltage.		
14	Is a reading greater than the DMM floor but less than 10 volts present?	15	27
15	The control loop is closed but inaccurate. Check for one-half the programmed output ($+5V \pm 0.01$ or -5 ± 0.01 volts) between the junction of R74, R77, R78, Q73 (High) and TP8 (Low).		
16	Is the reading correct?	18	17
	<p style="text-align: center;"><i>NOTE</i></p> <p><i>The ranging divider is not easily loaded by the integrator circuit; however, the possibility of loading does exist and it can be checked using the following procedure:</i></p> <p><i>a) Turn off power and remove the Analog PCB.</i></p> <p><i>b) Install the Power Amp on an Extender PCB and connect a variable isolated DC power supply between TP24 (+) and TP29 ().</i></p>		

Table 4-15. Analog Circuitry Troubleshooting (cont)

STEP NO.	ACTION	Go to the step number given for correct response	
		YES	NO
	<p><i>c) With a programmed output of 10V, increase the power supply output while monitoring the output terminals. For a swing of less than 10V from the supply the output terminals should swing from zero to approximately 35V. If the input polarity is reversed the swing should also reverse.</i></p> <p><i>d) The voltage at the coaxial connector, J54, in the Analog Control slot should be precisely one-half the measured output voltage.</i></p>		
17	Check Q1, U19, and their associated drive circuits on the Ranging PCB. Repair as required, then resume at step 9.		
18	With a high impedance DVM check for 5 ± 0.01 volts between U61-3 and TP8 (Low).		
19	Is the reading correct?	26	20
20	Check the reference voltage input to the DAC from common at A14 TP3 to A14 TP1 (+10V) and A14 TP4 (-10V).		
21	Is the reading correct?	23	22
22	Check the voltage reference circuit on the Analog Control PCB. Repair as required, then resume at step 9.		
23	Check the DAC for a 50% duty cycle drive waveform on TP10, TP7, and TP5. If the waveform is not present at TP5 check for the proper logic drive signals to the digital section. Check for the proper relay action using the schematic chart. Repair or replace as required.		
	<p style="text-align: center;"><i>NOTE</i></p> <p><i>To eliminate the possibility of loading the DAC from the Analog Control Integrator circuit the input may be removed by desoldering the integrator input line at the junction of Q62 and Q63.</i></p>		
24	Is the programmed output voltage present at the output terminals?	9	25
25	Check the Power Amp (A17) using the applicable Table. Repair as required, then resume at step 9.		
26	Check the Analog Control (A14) Integrator circuits Q68 (for excessive bias current), Q73, Q74, K3, and their associated components. Repair as required, then resume at step 9.		
27	The control loop is open. Check the Ranging (A11), Analog Control (A14), and Power Amp (A17) for proper closure of the relays and FETs using the applicable tables on the schematics. Repair as required, then resume at step 9.		
28	Prepare the test DMM connected to the output terminals to read approximately 1V dc, then program a calibrator output of +1V dc.		
29	Is the reading +1V dc $\pm 200 \mu\text{V}$?	31	30
30	Check K50, K14, and their associated logic circuits on the Ranging PCB. Repair as required, then resume at step 28.		
31	Program a calibrator output of +100 mV dc.		

Table 4-15. Analog Circuitry Troubleshooting (cont)





STEP NO.	ACTION	Go to the step number given for correct response	
		YES	NO
32	Does the test DMM read +100 mV dc $\pm 25 \mu\text{V}$?	34	33
33	Check K51, K14, and their associated logic circuits on the Ranging PCB. Repair as required, then resume at step 31.		
34	Program a calibrator output of +10 mV dc.		
35	Does the test DMM read +100 mV dc $\pm 10 \mu\text{V}$?	37	36
36	Check K52, K14, and their associated logic circuits on the Ranging PCB. Repair as required, then resume at step 34.		
37	Connect a test DMM prepared for DC current to the output terminals.		
38	Program a calibrator output of +100 mA dc and observe the DMM for a reading of +100 mA dc ± 0.1 mA.		
39	Program a calibrator output of -100 mA dc and observe the DMM for a reading of -100 mA dc ± 0.1 mA.		
40	Are both reading (steps 38 and 39) within the listed tolerances?	45	41
	CAUTION  F and  R float on the PA output during current operation. Do not short to any other ground in the system, i.e.,  S or  1 during the current tests." data-bbox="258 450 602 500"/>		
41	Check the control loop voltage between TP5 (high) and TP8 (low) on the Analog Control PCB.		
42	Is the absolute value greater than the DMM floor but less 10V?	44	43
43	The control loop is open. Check K1, K3, K5, K55, U19, and their associated logic circuits on the Ranging PCB. Check relay K2, K3, K7, K11, and their associated drivers on the Power Amp. If the fault is not located in the relays, check the Power Amp using the applicable table. Repair as required, then resume at step 37.		
44	The control loop is closed. Check the \pm reference voltage from the PS Regulator and Analog Control PCBs. The positive reference is called for negative current and vice versa. Check the DAC, beginning with the procedure in step 23, followed by checks of K2 (open) and Q6 through Q9 (on). With +100 mA programmed -1 +0.01V dc should be present at the junction C14/15 (high) and TP12 (low). Repair as required, then resume at step 37.		
45	Program a calibrator output of +1.9A dc.		
46	Does the test DMM read 1.9A dc ± 2 mA?	48	47
47	The only difference for the high current operation is the use of R1 (A11) and the high current amp (U106, Q142, Q143, and associated components) on the Power Amp. Repair as required, then resume at step 45.		
48	Program a calibrator output of 10V ac at 1 kHz.		
49	Does the test DMM read 10V ac ± 10 mV at the output terminals?	70	50
50	Check the control loop by measuring the DC voltage between TP5 (high) and TP8 (low) on the Analog Control PCB with 10V ac output programmed.		
51	Does the test DMM read more than its floor but less than 10V dc?	52	59
52	Measure the calibrator output voltage and the voltage between TP2 (high) and TP8 (low) on the Ranging PCB.		

Table 4-15. Analog Circuitry Troubleshooting (cont)

STEP NO.	ACTION	Go to the step number given for correct response	
		YES	NO
53	Is the voltage at the test points one-tenth (1/10) that of the output terminals?	56	54
54	Check the relay operation on the Ranging PCB using the table on the schematic. Check U8, Q2, and their associated circuits. Repair as required.		
55	Is 10V ac ± 10 mV present at the output terminals?	70	56
56	With the DMM low at TP8 on the Analog Control PCB, check the rms voltage at pin 38 P51 and the DC voltage at TP12.		
57	Is the positive value at TP12 equal to the rms voltage?	59	58
58	Check the AC Converter and/or Integrator on the Analog Control PCB for the following voltages from TP8 to the points given: 0 ± 1 mV at U42-2, $+1 \pm 0.5$ V at U37-2, and U37-3, and 8 ± 1 V at U37-6. Check the integrator input stages at Q74 with its drive circuits. Repair as required.		
59	Is 10V ac ± 10 mV present at the output terminals?	70	60
60	Check between TP3 (high) and TP4 (low) on the Oscillator PCB (A18) with an oscilloscope for a sine wave with no offset, and at the programmed frequency $\pm 3\%$.		
61	Is the oscillator output correct?	68	62
62	Is the DC voltage between TP2 (high) and TP4 (low) on the Oscillator PCB between 0 and -3 V?	65	63
63	Check, in sequence, the following items, checking with a DMM for 1.2 ± 0.1 V rms between TP3 (high) and TP4 (low) on the oscillator PCB after each item: Check relays of the Oscillator PCB using the chart on the schematic. Check op amps, U1 through U5 (0 ± 20 mV dc at pin 2), and their associated components. Check CR1 through CR4, VR1, and their associated components.		
64	Does the test DMM read 1.2 ± 0.1 V rms between TP3 (high) and TP4 (low) on the Oscillator PCB?	60	67
65	For frequency errors greater than 3%, check the FETs Q4 through Q11, and Q14 through Q21, and their drive logic. Repair as required.		
66	Does the frequency equal the 1 kHz ± 30 Hz entered in step 48?	60	67
67	Since arrival at this point is dependent upon all previous checks being correct, there is a possibility that some component was damaged during testing and the test should be restarted at step 1.		
68	Is 10V ac ± 10 mV present at the output terminals?	70	69
69	Perform the Power Amp test using the applicable table. Repair as required, then resume at step 48.		
70	Program a calibrator output of 10V ac at 50 kHz.		
71	Does the test DMM read 10V ac ± 20 mV at the Calibrator output terminals?	74	72
72	Is the frequency equal to 50 kHz ± 1.5 kHz?	73	60
73	For amplitude errors, restart at step 48, placing special emphasis on correct amplitude of test in steps 56 and 57, and in the DAC output of the power amp of P53. Repair as required, then resume at step 70.		
<p>CAUTION</p> <p>∇ F and ∇ R float on the PA output in the current ranges. Do not short to any other ground in the system, i.e., ∇ S or ∇ 1 during the current tests.</p>			

Table 4-15. Analog Circuitry Troubleshooting (cont)

STEP NO.	ACTION	Go to the step number given for correct response	
		YES	NO
74	Program a calibrator output of 100 mA ac at 400 Hz.		
75	At the calibrator output terminals, does the test DMM read 100.000 mA \pm 0.5 mA?	90	76
76	Remove the test DMM connected to the calibrator output terminals.		
77	Does the instrument display flash overload (O.L.) and return to STDBY after approximately 2 seconds?	78	79
78	Check the Power Amp Assembly using the applicable table, with special emphasis on the high voltage amp circuit. Repair as required, then resume at step 74.		
79	On the Ranging Assembly, check relays K1, K3, K5, K16, K55, and their associated circuitry. Check the AC voltage between TP2 (high) and TP8 (low) for an output proportional to the current at the output terminals, i.e., 1.05 \pm .002V ac should be at TP2 when 105 mA is at the output terminals. Repair as required.		
80	Is 100 \pm 0.5 mA ac now present at the output terminals?	90	81
81	On the Ranging Assembly check the AC buffer amp (U2), Q2, and their associated circuits and drivers. Repair as required.		
82	Is 100 \pm 0.5 mA ac now present at the output terminals?	90	83
83	On the Analog Control Assembly recheck the AC Converter and Integrator circuits using the procedure in step 56, 57, and 58. Repair as required.		
84	Is 100 \pm 0.5 mA ac now present at the output terminals?	90	85
85	Check the Power Amp Assembly using the applicable table with emphasis on the AC Current Mode. Repair as required.		
86	Is 100 \pm 0.5 mA ac now present at the output terminals?	90	87
87	Check the Oscillator Assembly using the procedure in steps 60 through 64.		
88	Is 100 \pm 0.5 mA ac now present at the output terminals?	90	89
89	Since arrival at this point is dependent upon all previous checks being correct, there is a possibility that some component was damaged during testing and the test should be restarted at step 1.		
90	Program a calibrator output of 1.9A ac at 400 Hz.		
91	Does the test DMM read 1.9A ac \pm 4 mA at the calibrator output terminals?	93	92
92	Check the Power Amp Assembly using the applicable table with emphasis on the high current amplifier. Repair as required, then resume at step 90.		
93	Disconnect the test DMM from the calibrator output terminals.		
94	With no load, does the Central Display briefly show O.L., then return to the reading present before the test DMM was removed, and does the calibrator drop in status to STDBY?	96	95
95	Check the Compliance Voltage Limiter and Detector circuit on the Analog Control Assembly. When the output terminal compliance voltage goes above 2.1V dc or peak AC, at 200 mA or higher, Q81 and Q82 should be conducting heavily to cause the high current amplifier on the Power Amp Assembly to go into current limit and signal the Controller an overload is present. Check the level detectors, U83 and U84, R84 through R87, which set the plus and minus "trip" voltages. Q88 and Q89 should be turned "on" for currents over 200 mA and "off" for currents under 200 mA. Repair as required and resume at step 93.		

Table 4-15. Analog Circuitry Troubleshooting (cont)

STEP NO.	ACTION	Go to the step number given for correct response	
		YES	NO
	WARNING DURING THE REMAINDER OF THE TEST, LETHAL VOLTAGES MAY BE PRESENT AT THE OUTPUT TERMINALS AND ON THE HIGH VOLTAGE OUTPUT ASSEMBLY A16.		
96	Program a calibrator output of 100V ac at 20 kHz and check at the output terminals for a DMM reading of $100 \pm 0.1V$ ac.		
97	Program a calibrator output of a 100V ac at 400 Hz and check at the output terminals for a DMM reading of $100 \pm 0.1V$ ac.		
98	Program a calibrator output of a 1000V ac at 400 Hz and check at the output terminals for a DMM reading of $1000 \pm 1V$ ac.		
99	Are all of the high voltage AC readings within tolerance?	101	100
100	Check the high voltage output (A16) with emphasis on T2 and K3, if the fault is only with the 20 kHz output, on T1 and K7, for 400 Hz faults, on K1 for 100V faults and on K2 for 1000V faults. If the problem cannot be located in the A16 Assembly, refer to the low voltage AC procedure beginning at step 48, since the high voltage is dependent upon a correct output from the low voltage circuits. Repair as required, then resume at step 96 or step 48 determined by the component replaced.		
101	Program a calibrator output of +100V dc and check the output terminals for a DMM reading of $+100 \pm 0.1V$ dc.		
102	Program a calibrator output of 1000V dc and check the output $+1000 \pm 1V$ dc.		
103	Are both dc voltage readings within their stated tolerances?	114	104
104	Program the calibrator for the first incorrect output.		
105	Is the output voltage greater than 20V dc?	112	106
106	Check the Ranging PCB (A11) for relay operation using the chart on the schematic. Begin with K56 and its drive logic.		
107	Is the programmed output present at the output terminals?	101	108
108	Check the waveform at TP11 of the Oscillator Assembly (A18).		
109	Is the waveform as depicted? (See Oscillator Waveforms in Section 8).	110	113
110	Check the Power Amp Assembly (A17) using the applicable table with emphasis on the connections and the high voltage amplifier. Repair as required.		
111	Is the programmed output present at the output terminals?	101	112
112	Check the High Voltage Output Assembly (A16) with emphasis on the high voltage DC path (CR1 through CR4, K5, K6, R35, through R39, U1, and associated components) and T1. Repair as required, then resume at step 101.		
113	Check the Oscillator Assembly (A18) using the procedure in steps 59 through 65. Repair as required, then resume at step 101.		
114	Troubleshooting of the analog circuits is complete.		

Table 4-16. Power Supply Regulator Troubleshooting

STEP NO.	ACTION	Go to the step number given for correct response	
		YES	NO
	<p style="text-align: center;"><i>NOTE</i></p> <p><i>The test can be performed, if desired, without placing the PCB on an extender, since all test points and adjustments on the Power Supply Regulator Assembly (A9) are accessible. However, to continue the test when a reading is out of tolerance, remove power from the instrument, wait at least 30 seconds, remove the PCB, return the PCB to the instrument on an extender PCB and reapply power. The first supply checked is the +15V(s) dc which is used as a reference for the -15V(s), ±62V, and ±30V supplies. The -15V references the -30V and -62V supplies, but since it is regulated by the +15V supply, that supply effectively references them all and if it is out of tolerance all others will be also. It should also be noted the -15V(s) is logic high (LH) and -20V(s) is logic common (LC) providing +5V logic for some circuits. If any supply reads out of tolerance check for ripple with an oscilloscope as the first step in troubleshooting. Typical ripple values for the power supply regulator voltages are given at the end of the table. The common connection between ($\frac{1}{2}$ S) and ($\frac{1}{2}$ J) is on the Ranging Assembly and if it is removed, a substitute connection must be made by connecting a jumper between TP13, and TP6.</i></p>		
1	With power removed from the instrument, remove the top and inner covers, then verify the correct placement of the line voltage selection switches and fuse valve.		
2	Reconnect the line cord and depress the POWER switch.		
3	Does the blower (fan) rotate?	5	4
4	Check the power source, line cord, line fuse, POWER switch, and line voltage selection switches. Repair as required and resume the test at step 2.		
5	Connect the test DVM, prepared for approximately +15V dc, between TP14 (high) and TP13 (low).		
6	Can the voltage be adjusted with R6 to between +14.99 and +15.01?	16	7
7	Is the reading more than +15.01?	8	9
8	Check Q2, U7, and their associated components. Repair as required, then resume the test at step 5.		
9	Transfer the voltmeter high input lead to the collector (center pin) of Q2.		
10	Is the reading greater than 17V?	12	11
11	Check the filtered DC V across C3 on the Aft Transformer Board (A8A2), the Bridge Rectifier (CR2), and the card-edge connectors on the Power Supply Motherboard. Repair as required, then resume at step 5.		
12	With the test DVM measure the voltage drops across R4 (1 ohm) on the P.S. Regulator.		
13	Is the reading greater than 0.65V?	15	14

Table 4-16. Power Supply Regulator Troubleshooting (cont)

STEP NO.	ACTION	Go to the step number given for correct response	
		YES	NO
14	Check Q2, U7, and their associated components. Repair as required, then resume at step 5.		
15	An excessive voltage drop is an indication of current limiting. Check CR14 and C13. If the trouble is not isolated, perform the subroutine beginning at step 154, then resume the test at step 5.		
16	Connect the test DVM, prepared for approximately $-15V$ dc, between TP12 (high) and TP13 (low).		
17	Is the reading between -14.85 and $-15.15V$ dc?	27	18
18	Is the reading greater than $-15.15V$ dc?	19	20
19	Check Q3, Q21, U8, and their associated components. Repair as required, then resume at step 16.		
20	Transfer the high input lead of the DVM to the collector (center pin) of Q3.		
21	Is the reading greater than $-17V$?	23	22
22	Check the filtered DC across C4 on the Aft Transformer Board (A8A2), the Bridge Rectifier, CR2, and the card-edge connectors on the P.S. Motherboard. Repair as required and resume the test at step 16.		
23	With the test DVM measure the voltage drop across R12 (1 ohm) on the P.S. Regulator.		
24	Is the reading greater than $0.65V$?	26	25
25	Check Q21, Q3, Q4, U8, and their associated components. Repair as required, then resume at step 16.		
26	An excessive voltage drop is an indication of current limiting. Check CR15 and C12. If the trouble is not isolated there, perform the subroutine beginning at step 154, then resume the test at step 16.		
27	Connect the test DVM, prepared for approximately $+62V$ dc, between Tp4 (high) and TP6 (low).		
28	Is the reading between $+60.0$ and $+64.0V$ dc?	38	29
29	Is the reading greater than $+64.0V$ dc?	30	31
30	Check Q5, Q6, Q8, U9, and their associated components. Repair as required, then resume the test at step 27.		
31	Transfer the high input lead of the DVM to the collector (center pin) of Q5.		
32	Is the reading greater than $69V$ dc?	34	33
33	Check the Bridge Rectifier, CR1, on the Aft Transformer Board (A8A2), the transformer output, and the card-edge connectors on the P.S. Motherboard. Repair as required and resume at step 27.		
34	With the test DVM, measure the voltage drop across R15 (1.1 ohm) on the P.S. Regulator.		
35	Is the reading greater than $0.65V$?	37	36
36	Check Q8, Q6, Q5, Q7, U9, and their associated components. Repair as required, then resume at step 27.		
37	An excessive voltage drop is an indication of current limiting. Remove the Power Amp Assembly from the instrument and recheck the voltage drop to isolate the problem to an assembly. If the problem remains, check C18, CR3, and the $+39V$ regulator. Repair as required, then resume the test at step 27.		
38	Connect the test DVM, prepared for approximately $+39V$ dc, between TP3 (high) and TP6 (low).		
39	Is the reading between $+37.5$ and $+40.5V$ dc?	49	40

Table 4-16. Power Supply Regulator Troubleshooting (cont)

STEP NO.	ACTION	Go to the step number given for correct response	
		YES	NO
40	Is the reading greater than +40.5V dc?	41	42
41	Check Q14, U12, and their associated components.		
42	Transfer the high input lead of the DVM to the collector (center pin) of Q14.		
43	Is the reading between +60 and +64V dc?	45	44
44	Return to step 27 and test the +62V dc power supply.		
45	With the test DVM measure the voltage drop across R32 (4.7 ohm) on the P.S. Regulator.		
46	Is the reading greater than 0.65V dc?	48	47
47	Check Q14, Q16, VR9, U12, and their associated components. Repair as required, then resume the test at step 38.		
48	An excessive voltage drop is an indication of current limiting. Remove the Power Amp Assembly from the instrument and recheck the voltage drop to isolate the problem to an assembly. If the problem remains, check C23 and CR9. Repair as required, then resume at step 38.		
49	Connect the test DVM, prepared for approximately -65V dc, between TP2 (high) and TP6 (low).		
50	Is the reading between -60 and -64V dc?	50	51
51	Is the reading greater than -64V dc?	52	53
52	Check Q9, Q11, Q12, U10, and their associated components. Repair as required, then resume the test at step 49.		
53	Transfer the high input lead of the DVM to the emitter of Q12.		
54	Is the reading greater than -69V dc?	56	55
55	Check the output of the Bridge Rectifier CR1 on the Aft Transformer Board (A8A2), the transformer output, and the card-edge connectors on the P.S. Motherboard. Repair as required, then resume at step 49.		
56	With the test DVM, measure the voltage drop across R25 (1.1 ohm).		
57	Is the reading greater than 0.65V?	59	58
58	Check Q9, Q10, Q11, Q12, VR8, U10, and their associated components. Repair as required, then resume at step 49.		
59	An excessive voltage drop is an indication of current limiting. Remove the Power Amp Assembly from the instrument and recheck the voltage drop to isolate the problem to an assembly. If the problem remains, check C19, CR25, and the -39V regulator. Repair as required, then resume the test at step 49.		
60	Connect the test DVM, prepared for approximately -39V dc, between TP5 (high) and TP6 (low).		
61	Is the reading between -37.5 and -40.5V dc?	71	62
62	Is the reading greater than -40.5V dc?	63	64
63	Check Q13, U13, and their associated components. Repair as required, then resume at step 60.		
64	Transfer the high input lead of the DVM to the collector of Q13.		
65	Is the reading between 60 and 64V dc?		
66	Return to step 49 and test the -62V dc.		
67	With the test DVM measure the voltage drop across R40 (4.7 ohm) on the P.S. Regulator.		
68	Is the reading greater than 0.65V?	69	70

Table 4-16. Power Supply Regulator Troubleshooting (cont)

STEP NO.	ACTION	Go to the step number given for correct response	
		YES	NO
69	Check Q13, Q17, VR10, U13, and their associated components. Repair as required, then resume the test at step 60.		
70	An excessive voltage drop is an indication of current limiting. Remove the Power Amp Assembly from the instrument and recheck the voltage drop to isolate the problem to an assembly. If the problem remains, check C26 and CR7. Repair as required, then resume the test at step 60.		
71	Connect the test DVM, prepared for approximately +5V dc, between TP12 (high) and TP1 (low).		
72	Can the reading be adjusted with R84 to between +4.9 and +5.3V dc?	85	73
73	Is the reading greater than +5.3V dc?	74	75
74	Check Q23, Q15, U11, and their associated components. Repair as required then resume at step 71.		
75	Transfer the high input lead of the DVM to the collector of Q15.		
76	Is the reading greater than +6.5V dc?	81	77
77	Transfer the high input lead of the DVM to the input side of fuse F-2.		
78	Is the reading greater than +6.5V dc?	79	80
79	Check F2 and the fuse holder. If the fuse is replaced and blows again, check Q15, Q23, U11, the triac Q20 and VR11 for an overload. Repair as required, then resume at step 71.		
80	Check the input from the rectifiers on the transformer board and the card-edge connectors on the P.S. Motherboard. Repair as required, then resume at step 71.		
81	With the test DVM measure the voltage drop across R31 (0.27 ohms).		
82	Is the reading greater than 0.65?	84	83
83	Check Q15, Q23, U11, and associated components. Repair as required then resume at step 71.		
84	An excessive voltage drop is an indication of current limiting. Check C63. If the trouble is not isolated there, perform the subroutine beginning at step 154, then resume the test at step 71.		
85	Connect the test DVM, prepared for approximately +5V dc, between TP17 (high) and TP18 (low).		
86	Can the reading be adjusted with R83 to between +4.9 and +5.3V dc?	99	87
87	Is the reading greater than +5.3V?	88	89
89	Transfer the high input lead of the DVM to the collector of Q1.		
90	Is the reading greater than +6.5V?	95	91
91	Transfer the high input lead of the DVM to the input side of the fuse F1.		
92	Is the reading greater than +6.5V?	93	94
93	Check F1 and the fuse holder. If the fuse is replaced and blows again, check Q1, Q22, U3, traic U19, and VR1 for an overload. Repair as required, then resume at step 85.		
94	Check the input from the rectifiers on the Aft Transformer Board (A8A2), and the card-edge connectors on the P.S. Motherboard. Repair as required, then resume at step 85.		
95	With the test DVM measure the voltage drop across R3 (0.27 ohms).		
96	Is the reading greater than 0.65V?	98	97
97	Check Q1, Q22, U3, and their associated components. Repair as required then resume at step 85.		
98	An excessive voltage drop is an indication of current limiting. Check the PCBs using the +5 Digital Bus for the path of excessive current. Repair as required, then resume at step 85.		

Table 4-16. Power Supply Regulator Troubleshooting (cont)

STEP NO.	ACTION	Go to the step number given for correct response	
		YES	NO
99	Connect the test DVM, prepared for approximately +12V dc, between TP16 (high) and TP18 (low).		
100	Is the reading between +11.25 and +12.75V dc?	108	101
101	Is the reading greater than +12.75V?	102	103
102	Check U1 and its associated components. Repair as required, then resume at step 99.		
103	Transfer the high input lead of the DVM to U1-1.		
104	Is the reading greater than +14V?	105	107
105	Is the case of the regulator U1 excessively warm to the touch?	106	107
106	Check C1 and CR10. Check the PCBs using the +12 (Vdd) on the Digital Bus for current limiting. Repair as required, then resume at step 99.		
107	Check the input from the rectifier on the Aft Transformer Board (A8A2), and the card-edge connectors on the P.S. Motherboard. Repair as required, then resume at step 99.		
108	Connect the test DVM, prepared for approximately -12V dc, between TP15 (high) and TP18 (low).		
109	Is the reading between -11.25 and -12.75V dc?	117	110
110	Is the reading greater than -12.75V?	111	112
111	Check U2 and its associated components. Repair as required then resume at step 108.		
112	Transfer the high input lead of the DVM to U2-3.		
113	Is the reading greater than -14V?	114	116
114	Is the case of the regulator U2 excessively warm to the touch?	115	116
115	Check C2 and CR11. Check the PCBs using the -12V (VGG) on the Digital Bus for current limiting. Repair as required, then resume at step 108.		
116	Check the input from the rectifier on the Aft Transformer Board (A8A2), and the card-edge connectors on the P.S. Motherboard. Repair as required, then resume at step 108.		
117	Connect the test DVM, prepared for approximately +5V dc, between TP8 (high) and TP9 (low).		
118	Is the reading between +4.75 and +5.25V dc?	126	119
119	Is the reading greater than +5.25V?	120	121
120	Check U4 and its associated components. Repair as required then resume at step 117.		
121	Transfer the high input lead of the DVM to U4-1.		
122	Is the reading greater than +7V?	123	125
123	Is the case of the regulator U4 excessively warm to the touch?	124	125
124	Check C4 and the PCBs using the +5V (FH) on the Digital Bus for current limiting. Repair as required, then resume at the step 117.		
125	Check the input from the rectifier on the Aft Transformer Board (A8A2), and the card-edge connector on the P.S. Motherboard. Repair as required, then resume at step 117.		
126	Connect the test DVM, prepared for approximately +15V, between TP11 (high) and TP10 (low).		
127	Is the reading between +14.25 and +15.75V?	135	128
128	Is the reading greater than +15.75V?	129	130
129	Check U5 and its associated components. Repair as required, then resume at step 126.		

Table 4-16. Power Supply Regulator Troubleshooting (cont)



STEP NO.	ACTION	Go to the step number given for correct response	
		YES	NO
130	Transfer the high input lead of the DVM to U5-1.		
131	Is the reading greater than +17V?	132	134
132	Is the case of the regulator U5 excessively warm to the touch?	133	134
133	Check C5 and CR12. Check the PCBs using the +15V (F) on the Digital Bus for current limiting. Repair as required, then resume at step 126.		
134	Check the input from the rectifiers on the Aft Transformer Board (A8A2), and the card-edge connector on the P.S. Motherboard. Repair as required, then resume at step 126.		
135	Connect the test DVM, prepared for approximately -15V, between TP7 (high) and TP10 (low).		
136	Is the reading between -14.25 and -15.75V dc?	144	137
137	Is the reading greater than -15.75V?	138	139
138	Check U5 and its associated components. Repair as required, then resume at step 135.		
139	Transfer the high input lead of the DVM to U6-3.		
140	Is the reading greater than -17V?	141	143
141	Is the case of the regulator U6 excessively warm to the touch?	142	143
142	Check C6 and CR13. Check the PCBs using the -15V (F) on the Digital Bus for current limiting. Repair as required, then resume at step 135.		
143	Check the input from the rectifiers on the Aft Transformer Board (A8A2), and the card-edge connectors on the P.S. Motherboard. Repair as required, then resume at step 135.		
144	Connect a scope prepared for a 60 Hz 5V square wave to U16-3 (high) and U16-1 (low).		
145	Is the scope amplitude between 4 and 5V and the period between 15.7 and 17.7 msec?	146	147
146	Check U16 and its associated components. Repair as required, then resume at step 144.		
147	Prepare a scope for triggered sweep, 50 ms per division, and 2V per division vertical sensitivity.		
148	Connect the scope between TP1 (low) and the junction point of the collector of Q18 and the bottom of R48 (high).		
149	Turn the calibrator POWER switch ON and OFF several times while observing the scope display.		
150	Does the display match either waveform 1 or 2 below?	158	151
	<p>WAVEFORM 1  NORMAL</p> <p>WAVEFORM 2  ACCEPTABLE</p> <p>WAVEFORM 3  NOT ACCEPTABLE</p>		

Table 4-16. Power Supply Regulator Troubleshooting (cont)

STEP NO.	ACTION	Go to the step number given for correct response	
		YES	NO
151	Does the scope display match waveform 3?	152	153
152	Check the one-shot multivibrator U14 and its control components CR19, C41, C42, and R45.		
153	If there is no transisiton, check at P11-16/36 for the 20V rms input to the circuit (at line frequency) which causes generation of waveform 1 above when power is applied to the circuit. Repair as required, then resume at step 147.		
154	Begin the subroutine to check for current limiting in the analog circuitry by removing one of the analog PCBs from the analog compartment.		
	<p><i>NOTE</i></p> <p><i>When the Ranging Assembly is removed, insure TP6 and TP13 are jumpered on the Power Supply Regulator to maintain continuity between the ground circuits.</i></p>		
155	Recheck the voltage drop on the applicable resistor to isolate the analog assembly causing the current limitng.		
156	Repeat the test removing one assembly at a time until the problem assembly is found.		
157	Use the troubleshooting table applicable for the faulty analog assembly to trace the problem, repair as required, then return to the step in the test calling out the subroutine.		
158	The test of the Power Supply Regulator is complete.		

NOMINAL DC VOLTAGE	TABLE STEP	TYPICAL READING IN PEAK TO PEAK VOLTS	
		RIPPLE	SPIKES
+15 ±0.01	6	2 mV	
-15 ±0.15	17	2 mV	
+62 ±2.0	28	20 mV	
+39 ±1.5	39	10 mV	
-62 ±2.0	50	20 mV	
-39 ±1.5	61	10 mV	
+5.1 ±0.2	72	100 mV	700 mV
+5.1 ±0.2	86	2 mV	5 mV
+12 ±0.75	100	30 mV	
-12 ±0.75	109	100 mV	
+5 ±0.25	118	100 mV	600 mV
+15 ±0.75	127	2 mV	
-15 ±0.75	135	2 mV	

Table 4-17. Power Amp Troubleshooting

STEP NO.	ACTION	Go to the step number given for correct response	
		YES	NO
	<i>NOTE</i> <i>All test points listed in this table are on the Power Amplifier Assembly (A17).</i>		
1	Remove power from the instrument, wait at least 30 seconds, then remove the PCB assembly from the instrument. Install the assembly in an extender PCB and install the combination in the instrument.		
2	Use the test DVM to check the input voltages to the Power Amplifier. The first test point listed is for the high input lead. If any voltages are out of tolerance, perform the test on the Power Supply Regulator. +15 \pm 0.05V dc between TP11 and TP23 -15 \pm 0.2V dc between TP12 and TP23 +39 \pm 1.5V dc between TP2 and TP23 -39 \pm 1.5V dc between TP5 and TP23 -20 \pm 0.25V dc between TP14 and TP23 +62 \pm 2.0V dc between TP7 and TP22 -62 \pm 2.0V dc between TP10 and TP22 -12 \pm 0.75V dc between TP20 and TP22 +12 \pm 0.75V dc between TP17 and TP22 +15 \pm 0.75V dc between TP30 and TP29 -15 \pm 0.75V dc between TP31 and TP29		
3	With the calibrator in STDBY, ground the HF Amp input by connecting a jumper between TP27 and TP23. Connect the test DVM between TP4 (high) and TP23 (low).		
4	Is the voltmeter reading 0 +0.1V dc?	6	5
5	A large output from the High Frequency Amplifier with the input grounded is an indication of problems within the amplifier. Trace the signal through the circuit until the source is found. Repair as required, then resume at step 3.		
6	Remove the grounding connection from TP27, prepare the test DVM to read approximately 10V ac and program an output of 10V ac at 400 Hz.		
7	Is the voltmeter reading between 9.9 and 10.1V ac?	18	8
8	Transfer the DVM high input lead to TP28.		
9	Is the voltmeter reading approximately 1.0V ac as an input from the Oscillator PCB?	11	10
10	Verify oscillator input at P81-37, then check K4 contacts, coil and logic circuits. Repair as required, then resume at step 6.		
11	Transfer the DVM high input lead to TP4 and connect TP27 to TP28 with a jumper to bypass the input photoresistor U103.		
12	Is the voltmeter reading between 15 and 25V ac?	14	13
13	Check the High Frequency Amplifier to isolate the faulty components using normal signal tracing techniques. Repair as required, then resume at step 6.		
14	Amplification with U103 eliminates the high frequency amp. Remove the jumper between TP27 and TP28. Check U103 and stimulate the Isolation Amplifier by connecting a 0 to +10V variable DC source between TP24 (+) and TP29 (common) with the common lead isolated from ground. Remove the Analog Control Assembly from the instrument, then program a 10V ac 400 Hz output and slowly vary the DC voltage source from zero to the maximum of 10 volts.		

Table 4-17. Power Amp Troubleshooting (cont)

STEP NO.	ACTION	Go to the step number given for correct response	
		YES	NO
15	Does the DVM reading vary between zero and 22V ac with the DC control voltage?	16	17
16	A tracking output is an indication that the Isolation Amplifier is working. Perform tests on the assemblies external to the Power Amp, beginning with the Ranging and Analog Control Assemblies. Repair as required, then return to the Power Amp test at step 6.		
17	Check the relays K4 and K3, the FET switches Q101, Q102, and their drives, and the Isolation Amplifier. Repair as required, then resume at step 6.		
18	With the DVM remaining connected between TP4 (high) and TP23 (low), and prepared for approximately 10V dc, program a calibrator output of +10.0V dc.		
19	Is the voltmeter reading between 9.9 and 10.1V dc?	34	20
20	Is the reading greater than 10.1V dc?	25	21
21	Transfer the DVM leads to TP24 (high) and TP29 (low).		
22	Is the reading greater than 10V dc?	23	24
23	Check the Isolation Amplifier circuitry, beginning with K3 and its logic circuits. Repair as required, then resume at step 18.		
24	Perform tests on assemblies external to the Power Amp, beginning with the Analog Control and the Ranging PCBs. Repair as required, then return to the Power Amp test at step 18.		
25	Transfer the DVM high input lead to TP21.		
26	Is the DVM reading greater than 10V?	28	27
27	Check the relays K7 and K8 for continuity, and relay K11 with its logic circuits. Repairs as required, then resume at step 18.		
28	Transfer the DVM high input lead to TP24.		
29	Is the DVM reading greater than +10V dc?	30	31
30	The Isolation Amplifier is responding correctly to the stimulus. Perform test on assemblies external to the Power Amp, beginning with the Analog Control and Ranging Assembly. Repair as required, then return to the Power Amp test at step 18.		
31	Is the DVM reading greater than -10V?	32	33
32	A negative control signal is an indication that the control loop is attempting to reduce the excessive output. Check the Isolation Amplifier circuit using standard signal tracing procedures. Repair as required, then resume at step 18.		
33	A low control voltage is an indication of trouble within another assembly. Perform tests on assemblies external to the Power Amp, beginning with Ranging and the Analog Control. Repair as required, then return to the Power Amp test at step 18.		
34	Prepare test DVM to read approximately 25V ac, then connect it between TP9 (high) and TP23 (low).		
35	Program the calibrator for an output of 20V ac 400 Hz.		
36	Is the DVM reading between 3.0 and 4.0V ac?	46	37
37	Is the DVM reading greater than 4V ac?	38	42
38	Transfer the DVM high input lead to TP21.		
39	Is the DVM reading still greater than 4V ac?	41	40
40	Check the K7A relay contacts and the associated circuitry. Repair as required, then resume at step 34.		

Table 4-17. Power Amp Troubleshooting (cont)

STEP NO.	ACTION	Go to the step number given for correct response	
		YES	NO
41	Perform tests on assemblies external to the Power Amp, beginning with the High Voltage and Ranging Assemblies and the signal path connecting those assemblies to the Power Amp. Repair as required, then return to the Power Amp test at step 34.		
42	Change the DVM settings to read a low DC voltage.		
43	Is the DVM reading greater than $0 \pm 0.2V$ dc?	44	45
44	Check the Low Frequency Amplifier, its input/output signals and the signal path through the circuit. Repair as required, then resume at step 34.		
45	Check the signal path for the High Frequency Amplifier output (TP4) through relays K7 and K8. Repair as required, then resume at step 34.		
46	Connect a test DVM, prepared to read approximately 15V ac, between TP4 (high) and TP23 (low). Connect a shorting link across the output terminals and program an output of 199 mA at 400 Hz.		
47	Is the DVM reading between 8 and 10V ac?	51	48
48	Is the DVM reading greater than 15V ac?	49	50
49	Check for an excessive voltage drop in the contacts of K7 and the card-edge connectors. Repair as required, then resume at step 46.		
50	Check relays K2, K5, and their logic circuits. Repair as required, then resume at step 46.		
51	Transfer the DVM high input lead to TP19. Then, with the output terminals still shorted, program an output of 1.99A at 400 Hz.		
52	Is the DVM reading between 1.5 and 3.5V ac?	56	53
53	Is the DVM reading greater than 3.5V ac?	54	55
54	Check for an excess voltage drop in the contacts of K7A and K8B, or in the card-edge connectors for the Power Amp and Ranging Assemblies. Repair as required, then resume at step 51.		
55	Check the High Current Amplifier (normal reading at TP4 w/1.99A programmed would be $11.5 \pm 1V$ ac). Trace the signal path through K7B, K8A, and the op amp U106. Repair as required, then resume at step 51.		
56	Connect a 10Ω resistor across the calibrator output terminals. Connect the test DVM, prepared for approximately 2V ac, between PAFB at J81-35 (high) and TP23 (low). Program an output of 199 mA at 400 Hz.		
57	Is the DVM reading between 1.98 and 2.00V ac?	59	58
58	Check the I-Guard Driver op amp (U1) and its associated components on the Ranging Assembly. Repair as required, then resume at step 56.		
59	Transfer the DVM high input lead to U105-6.		
60	Is the DVM reading between 1.98 and 2.00V ac?	62	61
61	Check the op amp U105 and its associated components. Repair as required then resume at step 59.		

Table 4-17. Power Amp Troubleshooting (cont)

STEP NO.	ACTION	Go to the step number given for correct response													
		YES	NO												
62	<p>The test of the Power Amplifier Assembly is complete.</p> <p style="text-align: center;"><i>NOTE</i></p> <p style="text-align: center;"><i>The four separate amplifiers on the Power Amp are checked using portions of the procedure above. If the problem has been isolated to a single amplifier the applicable steps are given below. If a test is made on only one amplifier, insure that all voltages are present, correct, and all prior equipment procedures have been previously performed.</i></p> <table border="0" style="width: 100%;"> <thead> <tr> <th style="text-align: left;">POWER AMP SECTION</th> <th style="text-align: left;">FAILURE MODE</th> <th style="text-align: left;">PROCEDURE STEPS</th> </tr> </thead> <tbody> <tr> <td>Isolation & H.F. Amps</td> <td>3-32</td> <td>DC V <20V AC & DC I <20 mA AC V <110V, 20 kHz AC V <20V, 50 kHz</td> </tr> <tr> <td>L.F. Amp</td> <td>33-50, 56-62</td> <td>AC V > 20V <1 kHz DC V >20V AC & DC I <200 mA</td> </tr> <tr> <td>High Current Amp (Incl. I-Guard on Ranging)</td> <td>51-62</td> <td>AC & DC I >200 mA</td> </tr> </tbody> </table>	POWER AMP SECTION	FAILURE MODE	PROCEDURE STEPS	Isolation & H.F. Amps	3-32	DC V <20V AC & DC I <20 mA AC V <110V, 20 kHz AC V <20V, 50 kHz	L.F. Amp	33-50, 56-62	AC V > 20V <1 kHz DC V >20V AC & DC I <200 mA	High Current Amp (Incl. I-Guard on Ranging)	51-62	AC & DC I >200 mA		
POWER AMP SECTION	FAILURE MODE	PROCEDURE STEPS													
Isolation & H.F. Amps	3-32	DC V <20V AC & DC I <20 mA AC V <110V, 20 kHz AC V <20V, 50 kHz													
L.F. Amp	33-50, 56-62	AC V > 20V <1 kHz DC V >20V AC & DC I <200 mA													
High Current Amp (Incl. I-Guard on Ranging)	51-62	AC & DC I >200 mA													

Table 4-18. Extended High Voltage Troubleshooting

STEP NO.	ACTION	Go to the step number given for correct response	
		YES	NO
	WARNING VOLTAGE UP TO 1600V MAY BE PRESENT ON THIS ASSEMBLY. PLACE THE 5100 SERIES B CALIBRATOR IN STDBY BEFORE ATTACHING OR TRANSFERRING TEST LEADS. <i>NOTE</i> <i>All test points in this table are on the High Voltage Output Assembly (A16).</i>		
1	Remove power from the instrument, wait at least 30 seconds, then remove the PCB assembly from the instrument. Remove the Control PCB from its mounting spacers and remount it on the transformer brackets so that it is at a 90° angle from its normal position. Install the assembly on an extender PCB and reinstall it in the equipment, insuring that the High Voltage Transformer has support and is not suspended in space.		
2	Connect the high input of a test voltmeter, prepared for AC volts, to the high terminal of P73 and the low input to TP10.		
3	Apply power to the instrument and program an output of 20V ac at 2 kHz.		
4	Voltmeter reads between 19.5 and 20.5V ac?	11	5
5	Voltmeter reads approximately zero?	6	10
6	Select STDBY, transfer the high lead to TP5 and select OPR.		
7	Voltmeter reading 3.5V or greater?	8	9
8	Check the relays K3 and K7, and their logic circuits. Repair as required, then resume at step 2.		
9	Check the connectors and the input from the Power Amplifier. Repair as required, then resume at step 2.		
10	For a non-zero, but out of tolerance reading, check the Ranging Assembly and/or Power Amplifier Assembly. When complete, resume the test at step 2.		
11	Program an output of 20V ac at 400 Hz. The high test lead is at P73.		
12	Voltmeter reads between 19.5 and 20.5V ac?	19	13
13	Voltmeter reads approximately zero?	14	18
14	Select STDBY, transfer the high lead to TP5, and select OPR.		
15	Voltmeter reads 2.8V ac or greater?	16	17
16	Check relays K1, K4, K7, and their logic circuits. Repair as required, then resume step 11.		
17	Check the connectors and the input from the Power Amplifier. Repair as required, then resume at step 11.		
18	For a non-zero but out of tolerance reading, check the Ranging Assembly and/or Power Amplifier Assembly. When complete, resume the test at step 11.		
19	With the high test lead at P73 HIGH and the test voltmeter prepared for DC volts, program an output of +20V dc.		
20	Voltmeter reads between 19.5 and 20.5V dc?	26	21
21	Voltmeter reads approximately zero?	22	26
22	Select STDBY, transfer the high lead to TP3, then select OPR.		

Table 4-18. Extended High Voltage Troubleshooting (cont)

STEP NO.	ACTION	Go to the step number given for correct response	
		YES	NO
23	Voltmeter reads between 18 and 22V dc?	24	25
24	Check relays K6, K7, and their logic circuits. Repair as required, then resume at step 19.		
25	Check the normally closed contacts of K4 and K5 and its logic circuit, rectifier CR1 through CR4, and the input from the Power Amplifier. Repair as required, then resume at step 19.		
26	With the high test lead at P73 HIGH, program an output of +300V dc.		
27	Voltmeter reads between 299.5 and 300.5V dc?	34	28
28	Voltmeter reads approximately zero?	29	33
29	Select STDBY, transfer the high lead to TP5 then select OPR.		
30	Voltmeter reads 9V or greater?	31	32
31	Check the relays K2, K6, K7, and their control logic, rectifier CR1 through CR4, and U1 with its associated circuitry. Repair as required, then resume at step 26.		
32	Check continuity and the input from the Power Amplifier. Repair as required, then resume at step 26.		
33	For a non-zero but out of tolerance reading, check the Ranging Assembly and/or Power Amplifier Assembly. When complete, resume the test at step 26.		
34	With the high test lead at P73 HIGH, program an output of +1100V dc.		
35	Voltmeter reads between 1099.5 and 1100.5V dc?	39	36
36	Does the Central Display flash overload (O.L.) and/or the calibrator return to standby?	37	38
37	Perform the Power Amplifier zero adjustment calibrator procedure. Repair as required, then resume the test at step 34.		
38	Check at TP5 with an oscilloscope (low to TP10) for a symmetric rounded square wave with an amplitude of approximately 35 volts. Check the Power Amp Assembly for low amplitude or an unsymmetrical waveform. Repair as required, then resume at step 34.		
39	With the voltmeter high test lead at P73 HIGH, program an output of 300V dc.		
40	Voltmeter reads between -299.5 and 300.5V dc?	42	41
41	Check relay K5, its logic circuit, the rectifier, and filter circuits. Repair as required, then resume at step 39.		
42	Connect a 2k ohm resistor to the output terminals of the calibrator. Connect an oscilloscope across the resistor.		
43	Program an output of +20V dc. With AC coupling selected, adjust the scope to display the ripple waveform.		
44	Is the displayed ripple waveform less than 30 mV peak-to-peak?	46	45
45	Check the filter circuit U1 and its associated circuitry. Repair as required, then resume the test at step 42.		
46	The test of the High Voltage Assembly is complete.		

Table 4-19. Controller Troubleshooting

STEP NO.	ACTION	Go to the step number given for correct response	
		YES	NO
	<p style="text-align: center;"><i>NOTE</i></p> <p style="text-align: center;"><i>Due to the speed and complexity of the Controller, it is recommended that when a problem is isolated to the Controller, the unit be sent to the nearest Fluke Service Center for repair. The following table will be of some assistance troubleshooting simpler problems; however, many problems will require the use of a Fluke Trendar or similar logic board tester.</i></p>		
1	Insure power is removed from the instrument, then, as a minimum, remove, the Extended High Voltage Assembly to preclude high voltages on the output terminals while troubleshooting. Removing all assemblies from the instrument motherboards except the Controller Assembly with its attached memory board, the Front Panel, the Power Supply, and either the Power Supply Interconnect (Non-Tape versions) or the Tape Interface (Tape versions) will prevent interaction from the Analog Assemblies from effecting operation of the Controller.		
2	Reapply power to the instrument.		
3	Does the display illuminate?	34	4
4	With a dual trace oscilloscope check the clock pulses at TP2 ($\phi 1$) and TP3 ($\phi 2$), and compare then to the following drawing.		
	<p style="text-align: center;">R1 adjusts $\phi 1$ during $\phi 2$</p>		
5	Are both clock pulses correct?	13	6
6	Are both clock pulses incorrect?	7	8
7	Check U3, U9, Y1, and their associated circuits in the 1.7 MHz clock. Repair as required, then resume at step 2.		
8	Is $\phi 2$ only incorrect?	9	10
9	Check U9 and its associated components in the clock and the μP U10. Repair as required, then resume at step 2.		
10	Is $\phi 1$ adjustable with R1?	11	12
11	Adjust for the proper waveform display, then resume at step 2.		
12	Check R1, U3, U9, and their associated components in the clock and the μP U10. Repair as required, then resume at step 2.		

Table 4-19. Controller Troubleshooting (cont)

STEP NO.	ACTION	Go to the step number given for correct response	
		YES	NO
13	Is a RST (reset) pulse present at U10-12 when the power switch is depressed?	15	14
14	Check U35, U34, U36, U38, U2, and their associated components in the reset circuitry. Repair as required then resume at step 2.		
	<i>NOTE</i> <i>Some of the following tests call out a check for a fluctuating signal. The data on the line cannot be decoded with the equipment available at this point, the only test being that the data is changing, i.e., the data line fluctuating between the two TTL data levels.</i>		
15	With an oscilloscope check for a fluctuating signal at U10-23.		
16	Is the line fluctuating?	22	17
17	Is the signal high at U10-23?	12	21
18	Is there a clock pulse at U1-12?	20	19
19	Check U2, U3, and their associated components in the clock circuitry. Repair as required, then resume at step 2.		
20	Check U1, U15, U16, U8, U18, their inputs, and their associated components in the Wait Logic and Status Latch circuitry. Repair as required, then resume at step 2.		
21	Check the ACK interrupt and Mark interrupt circuits (U14) and their output to U28. Repair as required, then resume at step 2.		
22	With an oscilloscope check the ACK line at P30-32 for a series of pulses followed by a rest period of approximately 2 msec.		
23	Are the pulses present?	27	24
24	Is the line high?	26	25
25	Check the mark interrupt circuit (U14-12, U37-3, and associated components). Check the phase lock circuit (U26, U34, and associated components) for the 2 msec pulses. Check the IC output lines and enable (U17-10, U29, U37-4). Repair as required then resume at step 2.		
26	Check the input to U38-6 and the associated components in the ACK Logic circuit. Repair as required then resume at step 2.		
27	Check the data lines (ID0-ID7) with an oscilloscope for an outgoing signal.		
28	Are the data lines fluctuating?	30	29
29	Check the IB Data gates U23, U24, U30; the enable IBOU at U17-9; and the μ P U10. Repair as required then resume at step 2.		
30	Check A15 (U10-36), WAIT (U10-24), WR(U10-18), DBIN(U10-7), and the remaining address lines (A0-A14) for a fluctuating signal.		
31	Are the signal lines fluctuating?	33	32
32	Check the ROM enable lines from the memory control (U31), the Memory Select Decoder circuit (U20), the ROMs and the μ P U10. Repair as required, then resume at step 2.		
33	If the trouble has not been isolated at this point and the display still has not illuminated, check the Interrupt Vector circuit (U28, U19, U37). If still defective, repeat the procedures in steps 2 through 33 a second time. If the fault still cannot be located, the assembly should be returned to a Fluke Service Center for repair.		

Table 4-19. Controller Troubleshooting (cont)

STEP NO.	ACTION	Go to the step number given for correct response	
		YES	NO
34	When energized with the analog modules removed, the Central Display should read "Err6" and the Output Display 0 mV dc.		
35	Does the Central Display read "Err6"?	37	36
36	Check the ACK INT and ACK circuits for lines held high or low. Repair as required, then resume at step 34.		
37	Does the Output Display read "0.000 mV dc"?	39	38
38	Check the data (ID0-ID7) and address (IC0-IC6) lines for an immobile line (one line permanently high or low). Repair as required, then resume at step 34.		
39	Program an instruction with the Front Panel.		
40	Does the instrument respond to the programmed instruction?	42	41
41	Check the ACK circuit and the data lines. Repair as required, then resume at step 34.		
42	Does the instrument have a remote or tape capability?	43	46
43	Select the applicable device.		
44	Does the instrument respond?	46	45
45	Check the INT (U17), INA (U37, U32), and INT VECTOR (U28, U19, U23) circuits. Repair as required, then resume at step 43.		
46	Test of the Controller at this level is now complete. If the Controller Assembly has been proven defective (preferred method, substitution with a known operational assembly), the assembly should be returned to a service center for disposition.		

Table 4-20. Isolator Troubleshooting

STEP NO.	ACTION	Go to the step number given for correct response	
		YES	NO
1	When power is applied does the display illuminate?	3	2
2	Check the address and data line inputs to the shift register. Repair as required, then resume at step 1.		
3	Does the display read "Err6"?	4	5
4	Check the address lines (IC0-IC6) through the input gates and unguarded shift register, the isolation transformer, and the guarded shift register and output gates. Check the ACK signal path through the assembly. Repair as required, then resume at step 1.		
5	Program various types of outputs and check the instrument output terminals after each programmed output for the correct value.		
6	Is the display of the programmed output correct and variable?	8	7
7	Check the data return (ID7), the applicable isolation transformer and the output latch and gates.		
8	Does the output match the programmed display?	10	9
9	Check the data lines (ID0-ID7) through the input gates and unguarded shift register, the isolation transformer, and the guarded shift register and output gates. Repair as required, then resume at step 5.		
10	Troubleshooting of the Isolator Assembly is complete.		

Table 4-21. Tape Interface Troubleshooting

STEP NO.	ACTION	Go to the step number given for correct response	
		YES	NO
	<i>NOTE</i> <i>During this procedure, the assumption is made that the Static Controller Assembly is operating correctly.</i>		
1	Remove power from the instrument, wait at least 30 seconds, then remove the instrument covers and guards. Mechanically detach and slide forward the Front Panel, using the applicable procedure in Section 4, to gain access to the component side of the Tape Interface Assembly (A8). Lay the Front Panel face down on the work area, leaving the ribbon cables connected, then remove all other PCB assemblies from the instrument except for the Tape Interface, Tape Drive, and Power Supply Regulator.		
2	Insert the Static Controller into the card-edge connector, from which the Controller was removed.		
3	Apply power to the instrument.		
4	Check between TP4 (HI) and TP1 (LO) with a test DVM.		
5	Is the voltage present between 4.75 and 5.25V dc?	7	6
6	Check the Power Supply Regulator using the applicable troubleshooting table and the cables connecting the Tape Interface Assembly to the Power Supply Regulator. Repair as required, then, resume at step 4.		
7	Place all switches on the Static Controller in the down position.		
8	Are any of the Static Controller LEDs illuminated?	9	10
9	Check the circuitry dealing with indicator illuminated (i.e., INT, ACK, ID0-7). Repair as required, then resume at step 7.		
10	Insure the DATA IN switch is down, then place the CONTROL OUT switch in the up position.		
11	One at a time, put IC3, IC5, and IC6 switches up, and check that the ACK indicator illuminates when the third switch goes up. Ignore the ID indicators.		
12	Return all IC switches to down.		
13	One at a time, put IC1, IC5, and IC6 switches up, and check that the ACK indicator illuminates when the third switch goes up. Ignore the ID indicators.		
14	Return all IC switches to down.		
15	Select DATA OUT with the CONTROL OUT switch in the up position.		
16	One at a time, put IC0, IC5, and IC6 switches up and check that the ACK indicator illuminates when the third switch goes up.		
17	Return all IC switches to down.		
18	One at a time, put IC2, IC3, and IC6 switches up, and check that the ACK indicator illuminates when the third switch goes up.		
19	Does the ACK indicator illuminate after the third switch for all four tests?	21	20
20	If the indicator fails to illuminate, check the ACK circuit between U16-13 and the connector. If it illuminates for one or more test, check the applicable input to U16-13. Repair as required then resume at step 10.		
21	Place a previously prepared, not completely rewound, tape in the tape drive unit. Use a scratch tape so operation will not be affected if the contents of the tape are lost.		

Table 4-21. Tape Interface Troubleshooting (cont)

STEP NO.	ACTION	Go to the step number given for correct response	
		YES	NO
22	Does the tape stay stationary; not moving in either direction?	26	23
23	Is the MOTION CMD signal (P33-17 or U21-11) at logic high level?	25	24
24	Check the logic generating the MOTION CMD signal. Repair as required, then resume at step 21.		
25	Repair or replace the tape drive unit, then resume at step 21.		
26	Place the DATA OUT, IC0, IC5, and IC6 switches up and all other switches down.		
27	Monitor the MOTION CMD with a scope and check for a high logic level when the CONTROL OUT switch is placed up and then down.		
28	Repeat step 27 with ID switches, ID0, ID1, ID2, and ID3, set up in turn, and check for the logic level listed at MOTION CMD when CONTROL OUT is toggled. ID0 – High ID1 – High ID2 – Low ID3 – High		
29	Is the correct logic level present at MOTION CMD for all tests?	31	30
30	Check the MOTION CMD generation circuitry and the control gates. Repair as required, then resume at step 26.		
31	Check the FWD/RWND CMD with the ID switches None (all down), ID0, ID1, ID2, and ID3 set to the up position, in turn, and check for the logic level listed at FWD/RWND CMD when CONTROL OUT is toggled. None – Low ID0 – Low ID1 – High ID2 – Low ID3 – Low		
32	Is the correct logic level present at FWD/RWND CMD for all tests? ✓	34	33
33	Check the FWD/RWND CMD generation circuitry and the control gates. Repair as required, then resume at step 31.		
34	Check the READ/WRITE signal with the ID switches None, ID0, ID1, ID2, and ID3, set to the up position, in turn, and check for the logic level listed at READ/WRITE when CONTROL OUT is toggled. None – Low ID0 – High ID1 – Low ID2 – Low ID3 – Low		
35	Is the correct logic level present at READ/WRITE for all tests?	37	36
36	Check the READ/WRITE generation circuitry and the control gates. Repair as required, then resume at step 34.		
37	Check the signal at U23-2 with the ID switches None, ID0, ID1, ID2, and ID3 set to the up position in turn, and check for logic level listed at U25-13 when CONTROL OUT is toggled.		

Table 4-21. Tape Interface Troubleshooting (cont)

STEP NO.	ACTION	Go to the step number given for correct response	
		YES	NO
	None – Low ID0 – Low ID1 – Low ID2 – Low ID3 – High		
38	Is the correct logic level present at U25-13 for all tests?	40	39
39	Check the inputs and output to U23. Repair as required, then resume at step 37.		
40	Select the DATA IN Mode with switches CONTROL OUT, IC1, IC5, and IC6 up and all remaining switches down.		
41	Monitor the ID4 indicator (ignore other indicators) while inserting and removing a fully rewound tape into the tape drive unit.		
42	Does ID4 indicator illuminate and extinguish as the tape is inserted and removed?	44	43
43	Check the TAPE POSITION signal (P33-2) circuitry. Repair as required, then resume at step 44.		
44	Toggle the top-left sense switch on the face of the tape drive unit.		
45	Does the ID5 indicator toggle with the sense switch?	47	46
46	Check the WRITE INHIBIT signal (P33-18) circuitry. Repair as required, then resume at step 44.		
47	Toggle the top-right sense switch on the face of the tape drive unit.		
48	Does the ID6 indicator toggle with the sense switch?	50	49
49	Check the SIDE A/B signal (P33-25) circuitry. Repair as required, then resume at step 47.		
50	Toggle the center sense switch on the face of the tape drive unit.		
51	Does the ID7 indicator toggle with the sense switch?	53	52
52	Check the CASSETTE LOADED signal (P33-26) circuitry. Repair as required, then resume at step 51.		
53	Remove power from the instrument, wait at least 30 seconds then disconnect P33 from the tape drive unit. When completed, reapply power to the instrument.		
54	Place switches IC0, IC5, IC6, ID0, ID1, ID3, and DATA OUT in the up position with all other switches down. Toggle the CONTROL OUT switch up then down, disregarding the indicators. This step prepares the interface.		
55	Place switches IC3, IC5, IC6, and CONTROL OUT up and all others down.		
56	Is the ACK indicator illuminated and the INT indicator extinguished? Disregard the ID indicators.	58	57
57	Check the bus line and driving signal of the incorrect indicator. Repair as required, then resume at step 55.		
58	Place all switches down, then place IC2, IC3, IC6, and DATA OUT switches in the up position.		
59	Place the CONTROL OUT switch up, then down.		
60	Does the INT indicator illuminate?	66	61
61	Is there a low logic level at U2-5?	65	62
62	Is there a low logic level at U26-1?	64	63
63	Check the write circuitry (refer to the Theory of Operation). Repair as required, then resume at step 55.		

Table 4-21. Tape Interface Troubleshooting (cont)

STEP NO.	ACTION	Go to the step number given for correct response	
		YES	NO
64	Check the circuitry controlling the signal at U27-10. Repair as required, then resume at step 55.		
65	Check the INT signal and its control logic. Repair as required, then resume at step 55.		
66	Connect with a jumper pins 5 and 19 of P33. Place switches IC3, IC5, and IC6 up and all others down.		
67	Place the CONTROL OUT switch up.		
68	Is the INT indicator extinguished?	70	69
69	Check the bus line and the logic signal controlling the INT line. Repair as required, then resume at step 67.		
70	Place all switches down, then place the DATA OUT, ID0, ID3, IC0, IC5, and IC6 in the up position.		
71	Toggle the CONTROL OUT switch up, then down (this step prepares the instrument for the next test).		
72	Place switches IC2, IC3, IC6, ID1, ID3, ID5, and ID7 up and all other switches down.		
73	Toggle the CONTROL OUT switch up then down.		
74	Does the INT indicator illuminate?	76	75
75	Check the bus line and the logic signal controlling the INT line. Repair as required, the resume at step 55.		
76	Is a low logic level present at U27-6?	79	77
77	Is a low logic level present at U26-13?	64	78
78	Check the read circuitry (refer to the Theory of Operation). Repair as required, then resume at step 55.		
79	Toggle the DATA IN switch up and down, then place the INA switch in the up position.		
80	Do the INT, ACK, and ID1 indicators illuminate?	82	81
81	Check the interrupt circuitry (refer to the Theory of Operation). Repair as required, then resume at step 55.		
82	Place all switches down, then place IC3, IC5, and IC6 in the up position.		
83	Place the CONTROL OUT switch in the up position.		
84	Do indicators ID1, ID3, ID5, and ID7 illuminate and ID0, ID2, ID4, and ID6 remain extinguished?	85	78
85	Is the INT indicator extinguished?	86	81
86	Is the ACK indicator extinguished?	87	88
87	Check acknowledge circuitry (refer to the Theory of Operation). Repair as required, then resume at step 55.		
88	Place the CONTROL OUT switch down.		
89	Remove power from the instrument, disconnect the jumper from P33 and reconnect P33 to the tape drive unit.		
90	Troubleshooting of the Tape Interface Assembly is complete.		

Section 5

List of Replaceable Parts

TABLE OF CONTENTS

ASSEMBLY NAME	DRAWING NO.	TABLE		FIGURE	
		NO.	PAGE	NO.	PAGE
Final Assembly 5100B	5100B-T&B; 5001	5-1	5-3	5-1	5-5
Final Assembly 5101B	5101B-T&B; 5001	5-2	5-11	5-2	5-14
Final Assembly 5102B	5102-T&B; 5001	5-3	5-21	5-3	5-24
A1 Main Motherboard PCB Assembly	5100A-4001T	5-4	5-32	5-4	5-33
A2 MIS Motherboard PCB Assembly	5100A-4002T	5-5	5-34	5-5	5-35
A3 Power Supply Motherboard PCB Assembly	5100A-4003T	5-6	5-36	5-6	5-37
A4 Interconnect PCB Assembly	5100A-4004	5-7	5-38	-	-
A5 Main Interconnect PCB Assembly	5100A-4005	5-8	5-38	-	-
A6 Interconnect, MIS PCB Assembly	5100A-4006	5-9	5-38	-	-
A7 Power Transformer Assembly	5100A-6520	5-10	5-38	-	-
A7A1 Forward Transformer Terminal PCB Assembly	5100A-4011	5-11	5-39	5-7	5-39
A7A2 Aft Transformer Terminal PCB Assembly	5100A-4012	5-12	5-40	5-8	5-40
A8 Power Supply Interconnect PCB Assembly	5010A-4130	5-13	5-41	-	-
A8 Tape Interface PCB Assembly	5101A-4130T	5-14	5-41	5-9	5-43
A9 Power Supply Regulator PCB Assembly	5100A-4010T	5-15	5-44	5-10	5-49
A10 Front Panel PCB Assembly, Non-Storage	5100A-4020T	5-16	5-50	5-11	5-57
A10 Front Panel PCB Assembly, Storage	5101A-4020T	5-17	5-58	5-12	5-65
A10A1 Display PCB Assembly	5100A-4020T	5-18	5-66	5-13	5-67
A11 Ranging PCB Assembly	5100A-4040T	5-19	5-68	5-14	5-75
A14 Analog Control PCB Assembly	5100A-4050T	5-20	5-74	5-15	5-79
A15 Digital-to-Analog Converter PCB Assembly	5100A-4060T	5-21	5-80	5-16	5-84
A16 Extended High Voltage PCB Assembly, Non Environmental Case ..	5100A-4071T	5-22	5-85	5-17	5-87
A16 Extended High Voltage PCB Assembly, Environmental Case	5102A-4071T	5-23	5-88	5-18	5-90
A16A1 High Voltage Control PCB Assembly	5100A-4072	5-24	5-91	5-18A	5-92
A17 Power Amplifier PCB Assembly	5100A-4080T	5-25	5-93	5-19	5-100
A17A1 Power Transistor PCB Assembly	5100A-4180T	5-26	5-101	5-20	5-101
A18 Oscillator PCB Assembly	5100A-4090T	5-27	5-102	5-21	5-105
A19 Isolator PCB Assembly	MIS-4181	5-28	5-106	5-22	5-108
A20 Controller PCB Assembly	5100A-4185T	5-29	5-109	5-23	5-112
A21 PROM-ROM-RAM PCB Assembly Non-Storage	5100A-4088T	5-30	5-113	5-24	5-116
A21 PROM-ROM-RAM PCB Assembly, Storage	5101A-4088T	5-31	5-114	5-24	5-116

5-1. INTRODUCTION

5-2. This section contains an illustrated parts breakdown of the instrument. A similar parts listing for each of the Options will be found in Section 6. Components are listed alphanumerically by assembly. Both electrical and mechanical components are listed by reference designation. Each listed part is shown in an accompanying illustration.

5-3. Parts lists include the following information:

1. Reference Designation.
2. Description of each part.
3. FLUKE Stock Number.
4. Federal Supply Code for Manufacturers. (See Section 7 for Code-to-Name list.)
5. Manufacturer's Part Number.
6. Total Quantity of components per assembly.
7. Recommended Quantity: This entry indicates the recommended number of spare parts necessary to support one to five instruments for a period of 2 years. This list presumes an availability of common electronic parts at the maintenance site. For maintenance for 1 year or more at an isolated site, it is recommended that at least one of each assembly in the instrument be stocked (see paragraph 5-7). In the case of optional subassemblies, plug-ins, etc., that are not always part of the instrument, or are deviations from the basic instrument model, the REC QTY column lists the recommended spares quantity for the items in that particular assembly.

5-4. HOW TO OBTAIN PARTS

5-5. Components may be ordered directly from the manufacturer by using the manufacturer's part number, or from the John Fluke Mfg. Co., Inc. or its authorized representatives by using the FLUKE STOCK NUMBER. In the event the part you order has been replaced by a new or improved part, the replacement will be accompanied by an explanatory note and installation instructions, if necessary.

5-6. To ensure prompt and efficient handling of your order, include the following information.

1. Quantity.
2. FLUKE Stock Number.
3. Description.
4. Reference Designation.
5. Printed Circuit Board Part Number and Revision Letter.
6. Instrument Model and Serial Number.

5-7. A Recommended Spare Parts Kit for your basic instrument is available from the factory. This kit contains those items listed in the REC QTY column of the parts list in the quantities recommended.

5-8. Parts price information is available from the John Fluke Mfg. Co., Inc. or its representatives. Prices are also available in a Fluke Replacement Parts Catalog, which is available on request.

CAUTION



Indicated devices are subject to damage by static discharge.

Table 5-1. Final Assembly 5100B

REF DES	DESCRIPTION	FLUKE STOCK NO.	MFG SPLY CODE	MFG PART NO. OR TYPE	TOT QTY	REC QTY	NOTE
	FINAL ASSEMBLY FIGURE 5-1 (5100B-T&B/5001)	5100B					
A1	MAIN MOTHER PCB ASSEMBLY	420315	89536	420315	1		
A2	MIS MOTHER PCB ASSEMBLY	455725	89536	455725	1		
A3	POWER SUPPLY MOTHER PCB ASSEMBLY	433003	89536	433003	1		
A4	DIAGONAL BUS PCB ASSEMBLY	420281	89536	420281	1		
A5	MAIN INTERCONNECT PCB ASSEMBLY	420299	89536	420299	1		
A6	MIS INTERCONNECT PCB ASSEMBLY	420307	89536	420307	1		
A7	POWER TRANSFORMER ASSEMBLY (50-400 HZ)	441048	89536	441048	1		
A7A1	FORWARD TRANSFORMER TERM PCB ASSEMBLY	ORDER	NEXT	HIGHER ASSEMBLY A7	1		
A7A2	AFT TRANSFORMER TERM PCB ASSEMBLY	ORDER	NEXT	HIGHER ASSEMBLY A7	1		
A8	POWER SUPPLY INTERCONNECT PCB ASSEMBLY	457226	89536	457226	1		
A9	⊗ POWER SUPPLY REGULATOR PCB ASSEMBLY	458398	89536	458398	1		
A10	⊗ FRONT PANEL PCB ASSEMBLY	458406	89536	458406	1		
A10A1	DISPLAY PCB ASSEMBLY	456004	89536	456004	1		
A11	⊗ RANGING PCB ASSEMBLY	458414	89536	458414	1		
A14	⊗ ANALOG CONTROL PCB ASSEMBLY	457705	89536	457705	1		
A15	⊗ DIGITAL-TO-ANALOG CONVERTER PCB ASSY.	458422	89536	458422	1		
A16	EXTENDED HI VOLTAGE OUTPUT PCB ASSEMBLY	510040	89536	510040	1		
A16A1	⊗ HI VOLTAGE CONTROL PCB ASSEMBLY	ORDER	NEXT	HIGHER ASSEMBLY A16	1		
A17	⊗ POWER AMP PCB ASSEMBLY	458448	89536	458448	1		
A17A1	POWER TRANSISTOR PCB ASSEMBLY	438606	89536	438606	1		
A18	⊗ OSCILLATOR PCB ASSEMBLY	458455	89536	458455	1		
A19	⊗ ISOLATOR PCB ASSEMBLY	455832	89536	455832	1		
A20	⊗ CONTROLLER PCB ASSEMBLY	477083	89536	477083	1		
A21	⊗ PROM-ROM-RAM PCB ASSY. (NON-STORAGE)	522821	89536	522821	1		
B1	FAN, MUFFIN VENTURI, 125V 14W	103374	89536	103374	1		
C32	CAP, MICA, 22 PF +/-5%, 500V	148551	72136	DM15E220J	1		1
H1	NUT,HEX	110569	89536	110569	2		
H2	NUT,HEX 10-32	110536	73734	8011-NP	4		
H3	SCREW. PHP, 2-56 X 1/4	149534	89536	149534	2		
H4	SCREW, SEMS 4-40 X 1/4	185918	89536	185918	8		
H5	SCREW, PHP, 4-40 X 1/4	129890	73734	19022	49		
H6	SCREW, PHP, SEMS, 4-40 X 3/8	281196	89536	281196	2		
H7	SCREW, SEMS, 6-32 X 1/4	178533	89536	178533	31		
H8	SCREW, PHP, 6-32 X 1/4	152140	89536	152140	2		
H9	SCREW, FH U/CUT, 6-32 X 1/4	320093	89536	320093	30		
H10	SCREW, SEMS, 6-32 X 1/2	177030	89536	177030	14		
H11	SCREW, SEMS, 6-32 X 5/8	272591	89536	272591	4		
H12	SCREW, PHP, 6-32 X 5/16	152157	89536	152157	2		
H13	SCREW, PHP, 6-32 X 7/16	362954	89536	362954	9		
H14	SCREW, FHP, 8-32 X 3/8	114116	73734	18264	16		
H15	SCREW, FHP, 8-32 X 5/16	281725	73734	18263	18		
H16	SCREW, NYLON LK, 8-32 X 5/16	460428	89536	460428	4		
H18	SCREW, CAP, 8-32	295105	89536	295105	4		
H19	WASHER, FLAT, .203 ID	110262	73734	AN960-10L	4		
H20	WASHER, FLAT	110288	73734	97425	6		
H21	WASHER, INT LK, #10	110312	73734	99406	4		
MP1	BRACKET, CAP MOUNT	426197	89536	426197	1		

Table 5-1. Final Assembly 5100B (cont)

REF DES	DESCRIPTION	FLUKE STOCK NO.	MFG SPLY CODE	MFG PART NO. OR TYPE	TOT QTY	REC QTY	NOTE
MP2	BRACKET, FRONT PANEL	421743	89536	421743	2		
MP3	BRACKET, CARD GUIDE	426213	89536	426213	1		
MP4	BRACKET, MIS MTG	421735	89536	421735	1		
MP5	BULKHEAD, FRONT	421685	89536	421685	1		
MP6	CARD PULLER	170951	89536	170951	1		
MP7	CHASSIS, INTERIOR, BOTTOM	421701	89536	421701	1		
MP8	CHASSIS, LEFT SIDE	443929	89536	443929	1		
MP9	CHASSIS, RIGHT SIDE	443937	89536	443937	1		
MP10	CLIP, MTG	422535	82877	271016	2		
MP11	COVER, BOTTOM	525899	89536	525899	1		
MP12	COVER, INNER	421727	89536	421727	1		
MP13	CORNER, REAR	426692	89536	426692	2		
MP14	PLATE, CONN COVER	426866	89536	426866	1		
MP15	COVER TOP	525881	89536	525881	1		
MP16	DECAL, CORNER	296285	89536	296285	4		
MP17	DECAL, HANDLE TRIM	295519	89536	295519	2		
MP18	DECAL, FRONT PANEL	429290	89536	429290	1		
MP19	DECAL, REAR PANEL	455683	89536	455683	1		
MP20	DECAL, SIDE TRIM	295402	89536	295402	2		
MP21	DORCAS, PLASTIC	421776	89536	421776	17		
MP22	FILTER ELEMENT	422543	82877	271018	1		
MP23	FRAME, FILTER	421750	89536	421720	1		
MP24	FOOT, BAIL STAND	292870	89536	292870	4		
MP25	GROMMET, RUBBER, 3/4 ID	380782	77969	68	2		
MP26	GROMMET, EXTRUDED	441782	06915	PGS-2	1		
MP27	HANDLE, FRONT PANEL	423178	89536	423178	2		
MP28	HOLDER, COMPONENT (RUBBER)	104794	98159	2829-115-3	1		
MP29	KNOB ASSY, FRONT PANEL	341446	89536	341446	1		
MP30	LENS DISPLAY, FRONT	429308	89536	429308	1		
MP31	NAMEPLATE, INTERIOR PANEL	393975	89536	393975	1		
MP32	PANEL, FRONT	522813	89536	522813	1		
MP33	PANEL, REAR	421651	89536	421651	1		
MP34	PARTITION, POWER SUPPLY	421693	89536	431693	1		
MP35	PLATE, ACCESS	426502	89536	426502	1		
MP36	GUIDE, PLATE (LO FREQ. XFMR)	425124	89536	425124	1		
MP37	PLATE, MIS BUS CONN	426841	89536	426841	2		
MP38	SHIELD, MIS PCB	420141	89536	420141	1		
MP39	SHIELD, PARTITION	426221	89536	426221	1		
MP40	SHIM, REAR CORNER	421784	89536	421784	2		
MP41	POST, SHRTNG LINK, BRASS/GOLD	190728	24655	0938-9503	1	1	
MP42	STANDOFF, NYLON INSUL, TAPPED	104174	89537	104174	2		
P14	CABLE, FLAT	380576	89536	380576	2		
P15	CABLE, FLAT	380576	89536	380576	REF		
TM1	INSTRUCTION MANUAL (NOT SHOWN)	522987	89536	522987	1		
TM2	OPERATOR'S MANUAL (NOT SHOWN)	523100	89536	523100	1		
W1	CORDSET, 3-WIRE (NOT SHOWN)	363481	89536	363481	1	1	
	RECOMMENDED SPARE PARTS KIT (NOT SHOWN)	530956	89536	530956	AR		
	1 ADDED IN TEST ON ALL PCB ASSEMBLY AS NEEDED.						

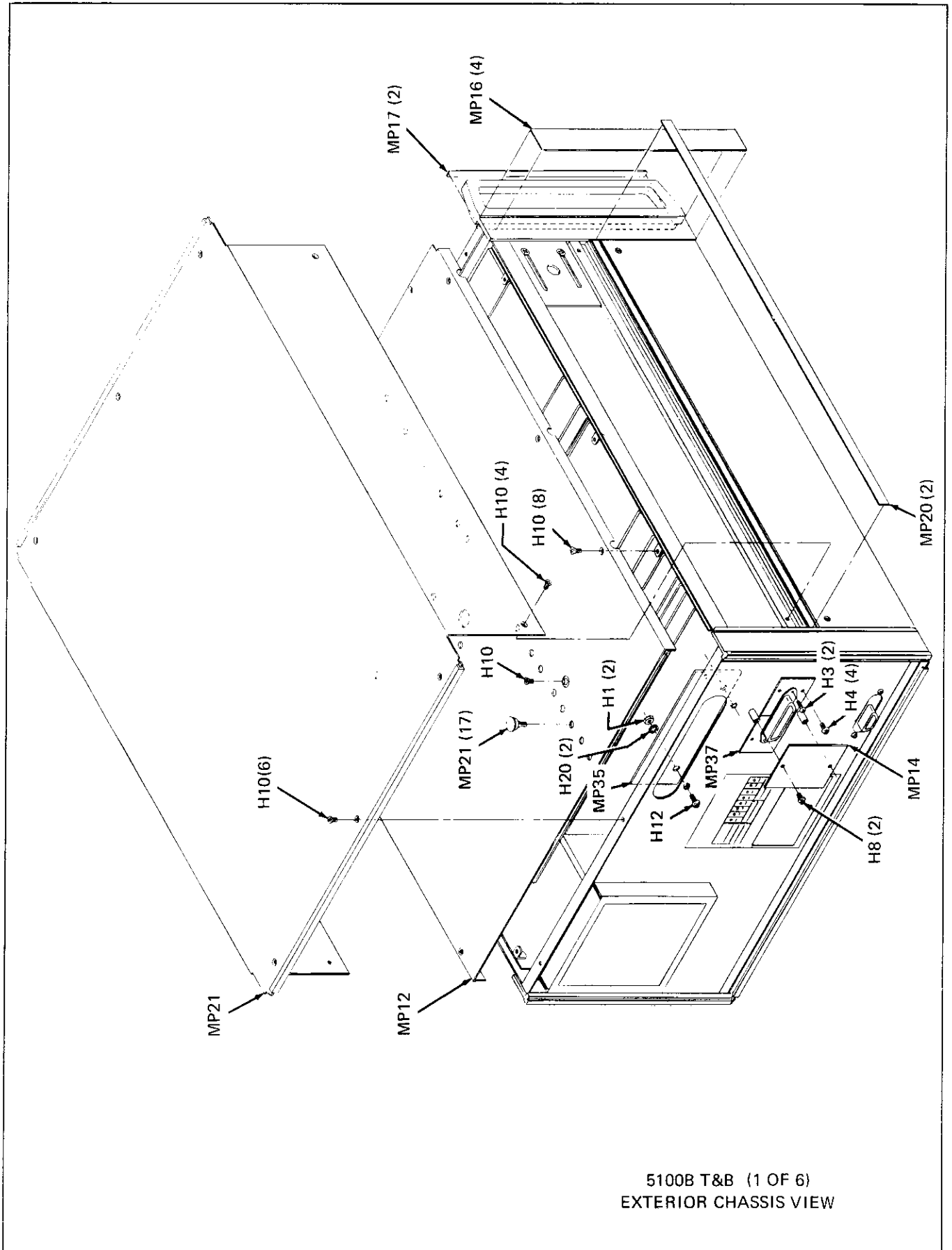

5100B T&B (1 OF 6)
EXTERIOR CHASSIS VIEW

Figure 5-1. Final Assembly 5100B

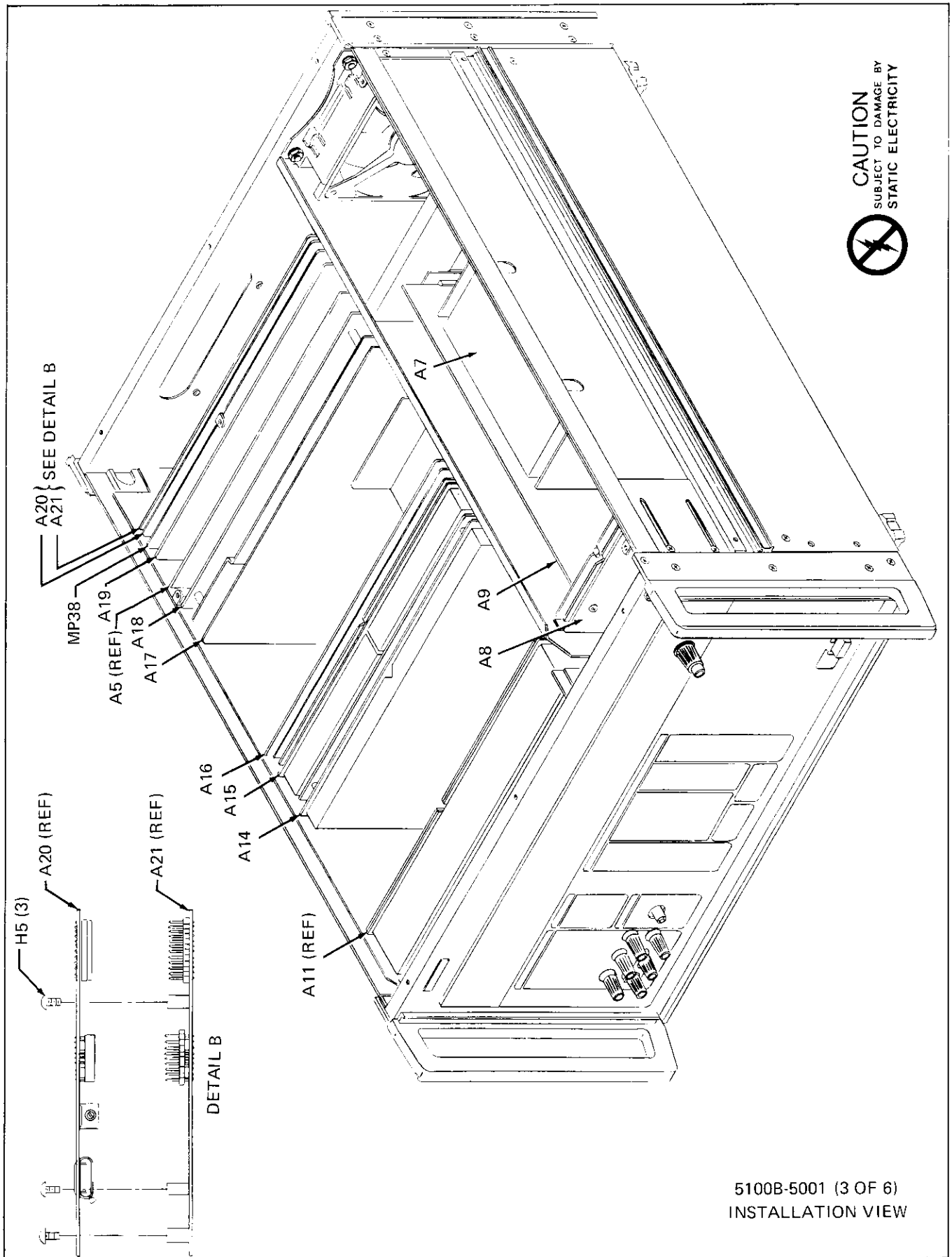

Figure 5-1. Final Assembly 5100B (cont)

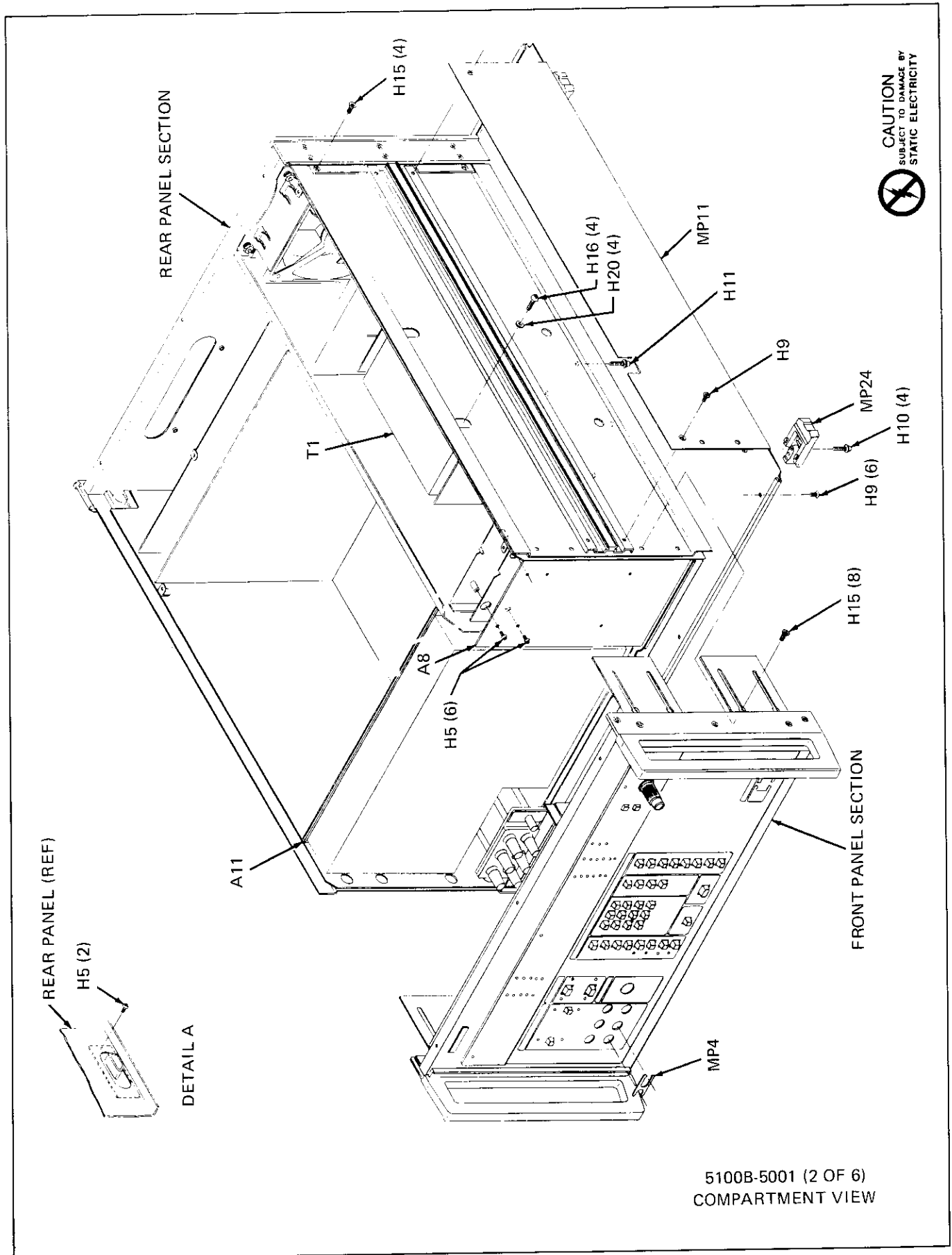

Figure 5-1. Final Assembly 5100B (cont)

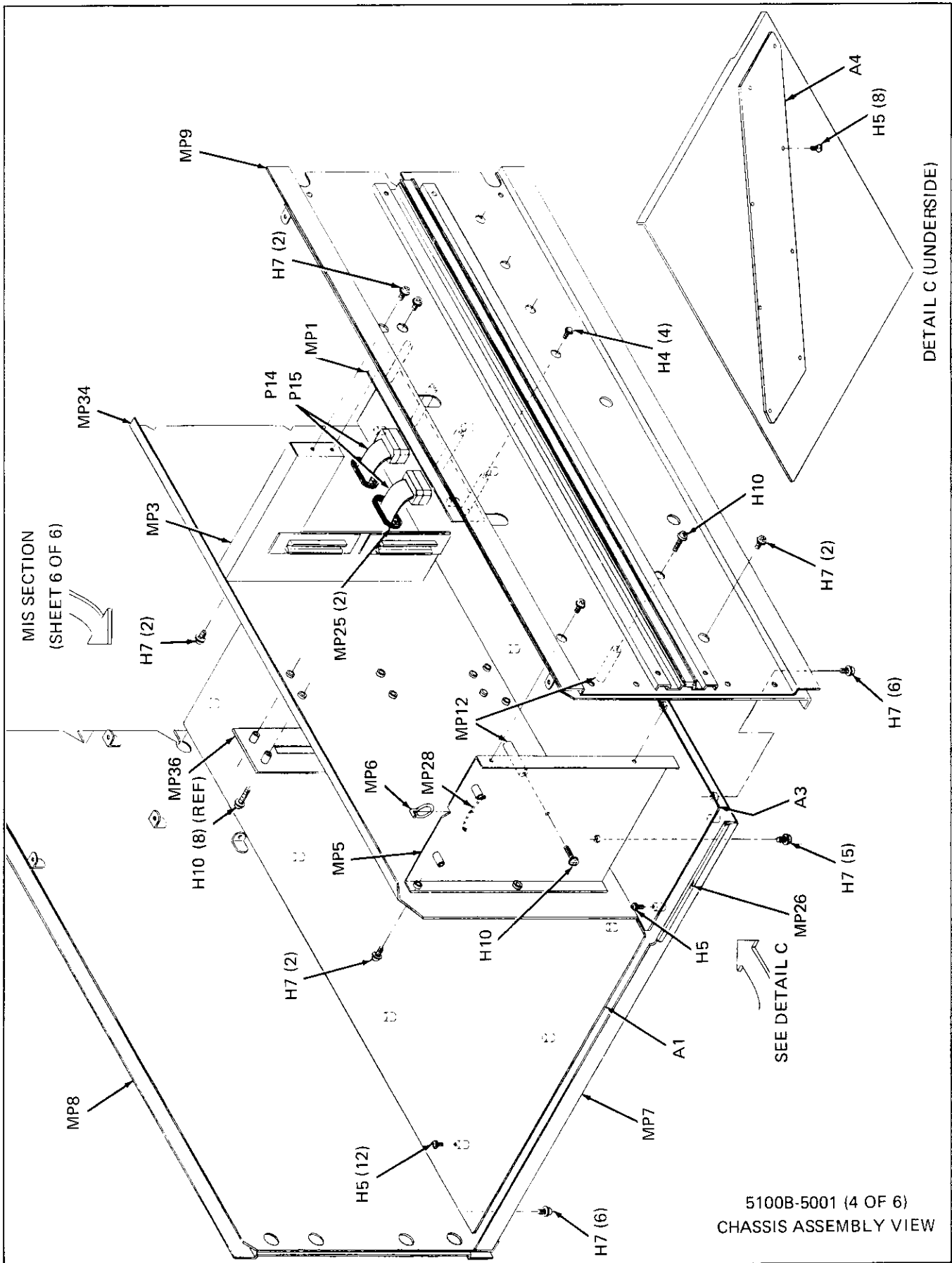

Figure 5-1. Final Assembly 5100B (cont)

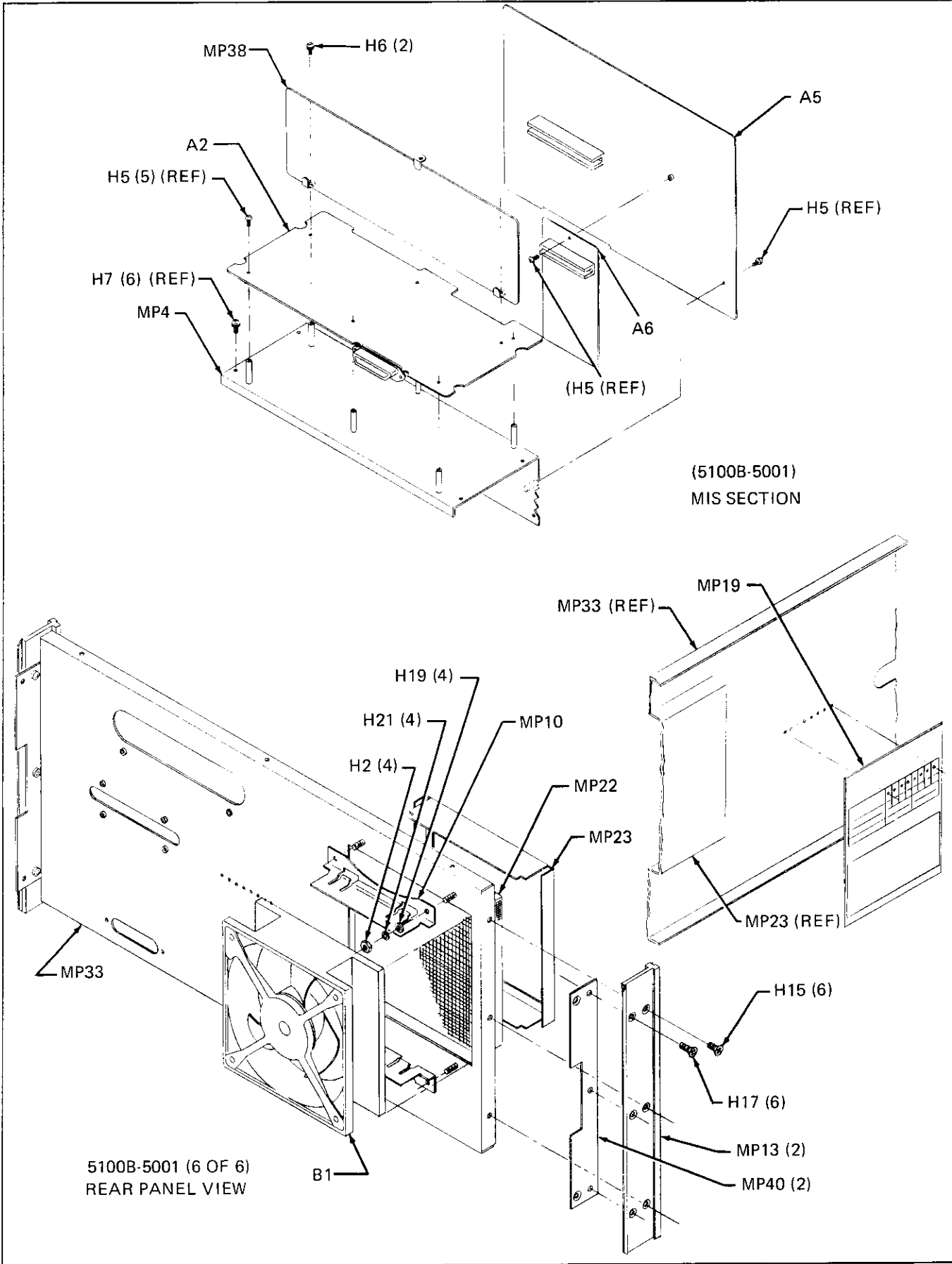
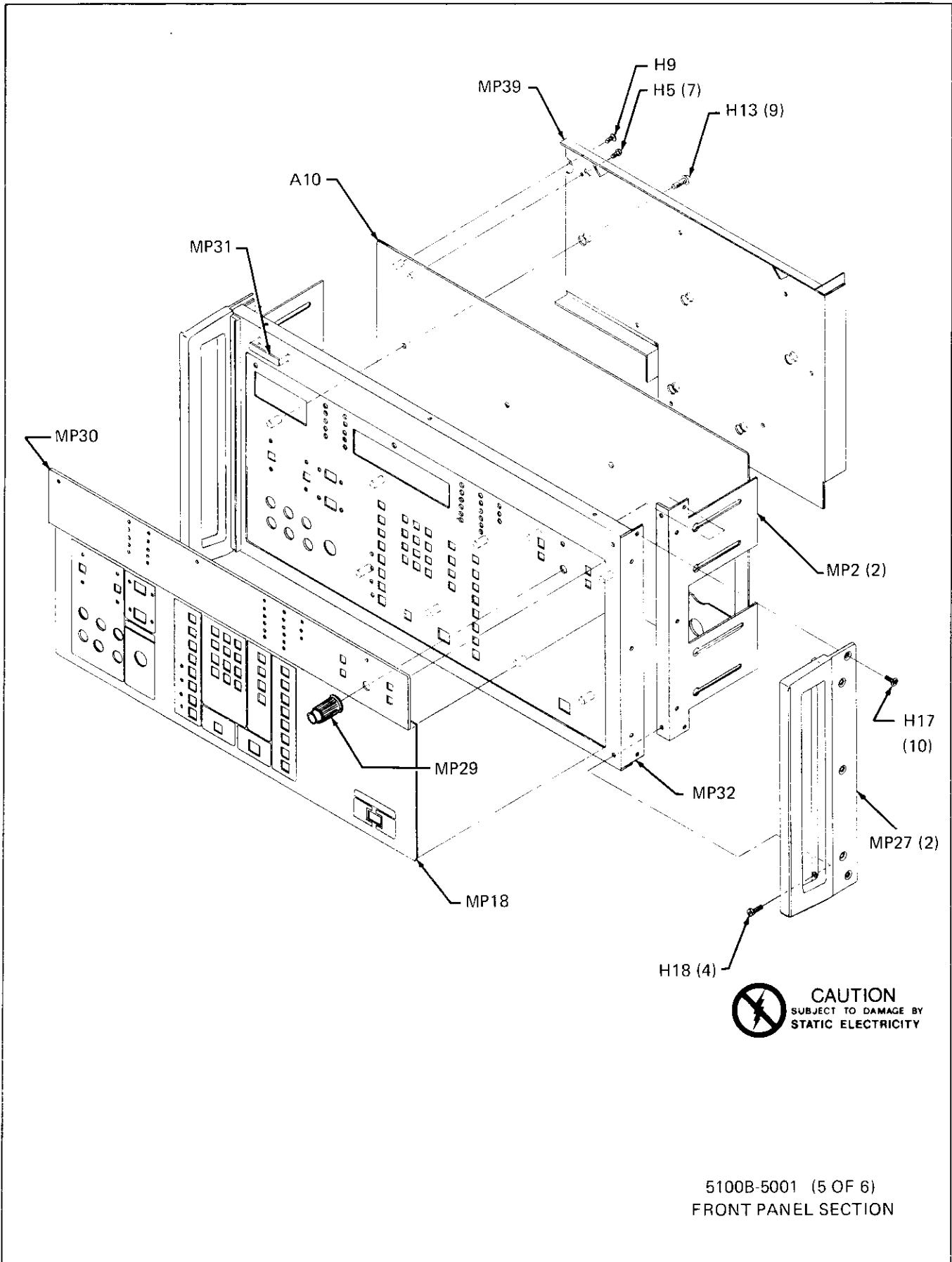

Figure 5-1. Final Assembly 5100B (cont)



5100B-5001 (5 OF 6)
FRONT PANEL SECTION

Figure 5-1. Final Assembly 5100B (cont)

Table 5-2. Final Assembly 5101B

REF DES	DESCRIPTION	FLUKE STOCK NO.	MFG SPLY CODE	MFG PART NO. OR TYPE	TOT QTY	REC QTY	N O T E
A	FINAL ASSEMBLY FIGURE 5-2 (5101B-T&B/5001)	5101B					
A1	MAIN MOTHER PCB ASSEMBLY	420315	89536	420315	1		
A2	MIS MOTHER PCB ASSEMBLY	455725	89536	455725	1		
A3	POWER SUPPLY MOTHER PCB ASSEMBLY	433003	89536	433003	1		
A4	DIAGONAL BUS PCB ASSEMBLY	420281	89536	420281	1		
A5	MAIN INTERCONNECT PCB ASSEMBLY	420299	89536	420299	1		
A6	MIS INTERCONNECT PCB ASSEMBLY	420307	89536	420307	1		
A7	POWER TRANSFORMER ASSEMBLY (50-400 HZ)	441048	89536	441048	1		
A7A1	FORWARD TRANSFORMER TERM. PCB ASSY.	ORDER	NEXT	HIGHER ASSEMBLY A7	1		
A7A2	AFT TRANSFORMER TERM PCB ASSEMBLY	ORDER	NEXT	HIGHER ASSEMBLY A7	1		
A8	⊗ TAPE INTERFACE PCB ASSEMBLY	458794	89536	458794	1		
A9	⊗ POWER SUPPLY REGULATOR PCB ASSEMBLY	458398	89536	458398	1		
A10	⊗ FRONT PANEL PCB ASSEMBLY	459537	89536	459537	1		
A10A1	DISPLAY PCB ASSEMBLY	456004	89536	456004	1		
A11	⊗ RANGING PCB ASSEMBLY	458414	89536	458414	1		
A14	⊗ ANALOG CONTROL PCB ASSEMBLY	457705	89536	457705	1		
A15	⊗ DIGITAL-TO-ANALOG CONVERTER PCB ASSEMBLY	458422	89536	458422	1		
A16	EXTENDED HI VOLTAGE OUTPUT PCB ASSEMBLY	510040	89536	510040	1		
A16A1	⊗ HI VOLTAGE CONTROL PCB ASSEMBLY	ORDER	NEXT	HIGHER ASSEMBLY A16	1		
A17	⊗ POWER AMP PCB ASSEMBLY	458448	89536	458448	1		
A17A1	POWER TRANSISTOR PCB ASSEMBLY	438606	89536	438606	1		
A18	⊗ OSCILLATOR PCB ASSEMBLY	458455	89536	458455	1		
A19	⊗ ISOLATOR PCB ASSEMBLY	455832	89536	455832	1		
A20	⊗ CONTROLLER PCB ASSEMBLY	477083	89536	477083	1		
A21	⊗ PROM-ROM-RAM PCB ASSY. (STORAGE)	522854	89536	522854	1		
B1	FAN, MUFFIN VENTURI, 125V 14W	103374	89536	103374	1		
C32	CAP, MICA, 22 PF +/-5%, 500V	148551	72136	DM15E220J	1		1
H1	NUT, HEX 6-32	110569	89536	110569	2		
H2	NUT, HEX 10-32	110536	73734	8011-NP	4		
H3	SCREW, PHP, 2-56 X 1/4	149534	89536	149534	2		
H4	SCREW, SEMS 4-40 X 1/4	185918	89536	185918	8		
H5	SCREW, PHP, 4-40 X 1/4	129890	73734	19022	59		
H6	SCREW, PHP, SEMS, 4-40 X 3/8	281196	89536	281196	2		
H7	SCREW, SEMS, 6-32 X 1/4	178533	89536	31	31		
H8	SCREW, PHP, 6-32 X 1/4	152140	89536	152140	2		
H9	SCREW, FH U/CUT, 6-32 X 1/4	320093	89536	320093	30		
H10	SCREW, SEMS, 6-32 X 1/2	177030	89536	177030	14		
H11	SCREW, SEMS, 6-32 X 5/8	272591	89536	272591	4		
H12	SCREW, PHP, 6-32 X 5/16	152157	89536	152157	2		
H13	SCREW, PHP, 6-32 X 7/16	362954	89536	362954	9		
H14	SCREW, FHP, 8-32 X 3/8	114116	73734	18264	16		
H15	SCREW, FHP, 8-32 X 5/16	281725	73734	18263	18		
H16	SCREW, NYLON LK, 8-32 X 5/16	460428	89536	460428	4		
H17	SCREW, FHP, 8-32 X 5/8	184994	89536	184994	1		
H18	SCREW, CAP, 8-32	295105	89536	295105	4		
H19	WASHER, FLAT, .203 ID	110262	73734	AN960-10L	4		
H20	WASHER, FLAT	110288	73734	97425	6		
H21	WASHER, INT LK, #10	110312	73734	99406	4		

Table 5-2. Final Assembly 5101B (cont)

REF DES	DESCRIPTION	FLUKE STOCK NO.	MFG SPLY CODE	MFG PART NO. OR TYPE	TOT QTY	REC QTY	N O T E
H22	WASHER, FIBER	130021	89536	130021	2		
MP1	BRACKET, CAP MOUNT	426197	89536	426197	1		
MP2	BRACKET, FRONT PANEL	421743	89536	421743	2		
MP3	BRACKET, CARD GUIDE	426213	89536	426213	1		
MP4	BRACKET, MIS MTG	421735	89536	421735	1		
MP5	BULKHEAD, FRONT	421685	89536	421685	1		
MP6	CARD PULLER, ACCESSORY	170951	89536	170951	1		
MP7	CHASSIS, INTERIOR, BOTTOM	421701	89536	421701	1		
MP8	CHASSIS, LEFT SIDE	443929	89536	443929	1		
MP9	CHASSIS, RIGHT SIDE	443937	89536	443937	1		
MP10	CLIP, MTG	422535	82877	271016	2		
MP11	COVER, BOTTOM	525899	89536	525899	1		
MP12	COVER, INNER	421727	89536	421727	1		
MP13	CORNER, REAR	426692	89536	426692	2		
MP14	PLATE, CONN COVER	426866	89536	426866	1		
MP15	COVER TOP	525881	89536	525881	1		
MP16	DECAL, CORNER	296285	89536	296285	4		
MP17	DECAL, HANDLE TRIM	295519	89536	295519	2		
MP18	DECAL, FRONT PANEL	453738	89536	453738	1		
MP19	DECAL, REAR PANEL	455683	89536	455683	1		
MP20	DECAL, SIDE TRIM	295402	89536	295402	2		
MP21	DORCAS, PLASTIC	421776	89536	421776	17		
MP22	FILTER ELEMENT	422543	82877	271018	1		
MP23	FRAME, FILTER	421750	89536	421720	1		
MP24	FOOT, BAIL STAND	292870	89536	292870	4		
MP25	GROMMET, RUBBER, 3/4 ID	380782	77969	68	2		
MP26	GROMMET, EXTRUDED (.40 FT)	441782	06915	PGS-2	1		
MP27	HANDLE, FRONT PANEL CORNER	423178	89536	423178	2		
MP28	HOLDER, 3-IN. RUBBER COMPONENT	104794	98159	2829-115-3	1		
MP29	KNOB ASSEMBLY, BLACK	341446	89536	341446	1		
MP30	LENS DISPLAY, FRONT	429308	89536	429308	1		
MP31	NAMEPLATE, SERIAL NO.	393975	89536	393975	1		
MP32	PANEL, FRONT	522847	89536	522847	1		
MP33	PANEL, REAR	421651	89536	421651	1		
MP34	PARTITION, POWER SUPPLY	421693	89536	431693	1		
MP35	PLATE, ACCESS	426502	89536	426502	1		
MP36	GUIDE, PLATE (LO FREQ. XFMR)	425124	89536	425124	1		
MP37	PLATE, MIS BUS CONN	426841	89536	426841	2		
MP38	SHIELD, MIS PCB	420141	89536	420141	1		
MP39	SHIELD/PARTITION ASSEMBLY	426221	89536	426221	1		
MP40	SHIM, REAR CORNER	421784	89536	421784	2		
MP41	POST, SHRTNG LINK, BRASS/GOLD	190728	24655	0938-9503	1	1	
MP42	MOUNTING RAIL, TAPE DECK	455584	89536	455584	1		
MP43	MOUNTING RAIL, TAPE DECK	455592	89536	455592	1		
MP44	DOOR, TAPE DECK	455600	89536	455600	1		
MP45	BRACKET, MOUNTING (TAPE DECK)	455618	89536	455618	1		
MP46	HINGE PIN (TAPE DECK)	455626	89536	455626	1		
MP47	WINDOW DECAL (DECK TAPE DOOR)	453704	89536	453704	1		
MP48	TAPE RECORDER (MINIATURE)	429688	89536	429688	1		
MP49	CABLE INSULATOR	457994	89536	457994	1		

Table 5-2. Final Assembly 5101B (cont)

REF DES	DESCRIPTION	FLUKE STOCK NO.	MFG SPLY CODE	MFG PART NO. OR TYPE	TOT QTY	REC QTY	N O T E
MP50	HINGE SPRING (LEFT)	453712	89536	453712	1		
MP51	HINGE SPRING (RIGHT)	453720	89536	453720	1		
MP52	CASSETTE TAPE	446997	89536	446997	1		
MP53	SPACER, 5/16 X 1 1/16	104174	89536	104174	2		
P14	CABLE, FLAT	380576	89536	380576	2		
P15	CABLE, FLAT	380576	89536	380576	REF		
TM1	INSTRUCTION MANUAL (NOT SHOWN)	522987	89536	522987	1		
TM2	OPERATOR'S MANUAL (NOT SHOWN)	523100	89536	523100	1		
W1	CORDSET, 3-WIRE (NOT SHOWN)	363481	89536	363481	1	1	
	RECOMMENDED SPARE PARTS KIT	530964	89536	530964	AR		
	1 ADDED IN TEST ON ALL PCB ASSEMBLY AS NEEDED.						

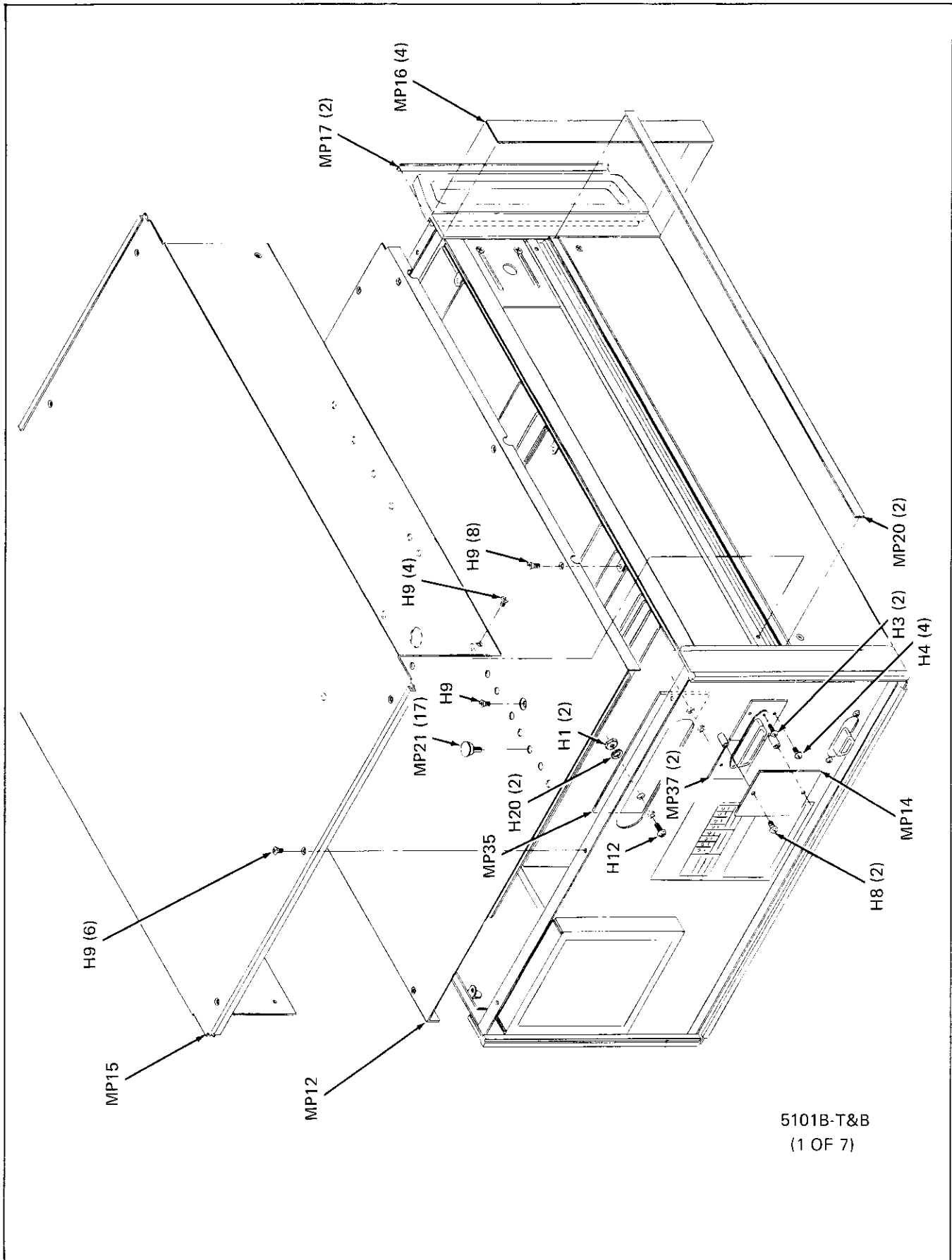
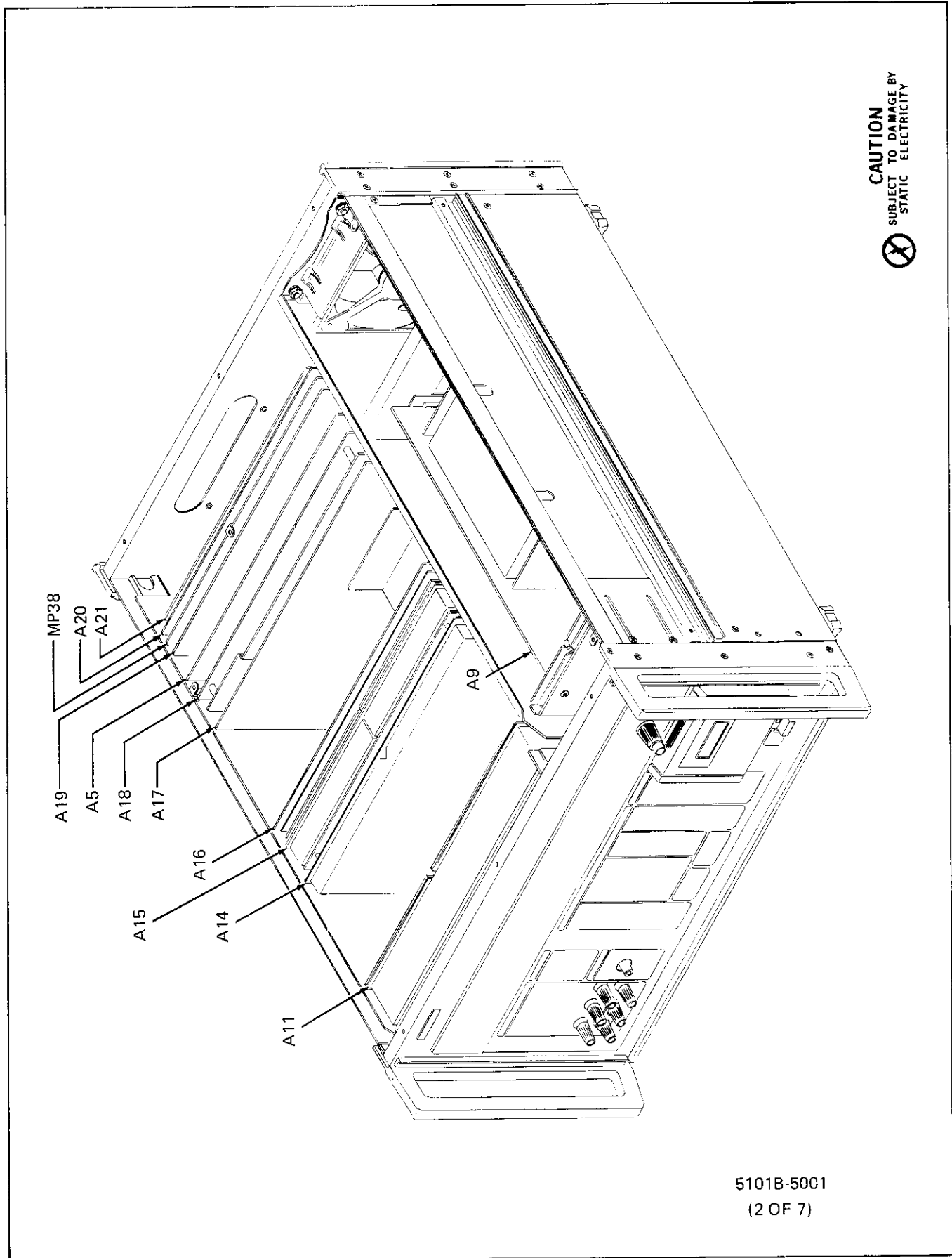

Figure 5-2. Final Assembly 5101B



5101B-5001
(2 OF 7)

Figure 5-2. Final Assembly 5101B (cont)

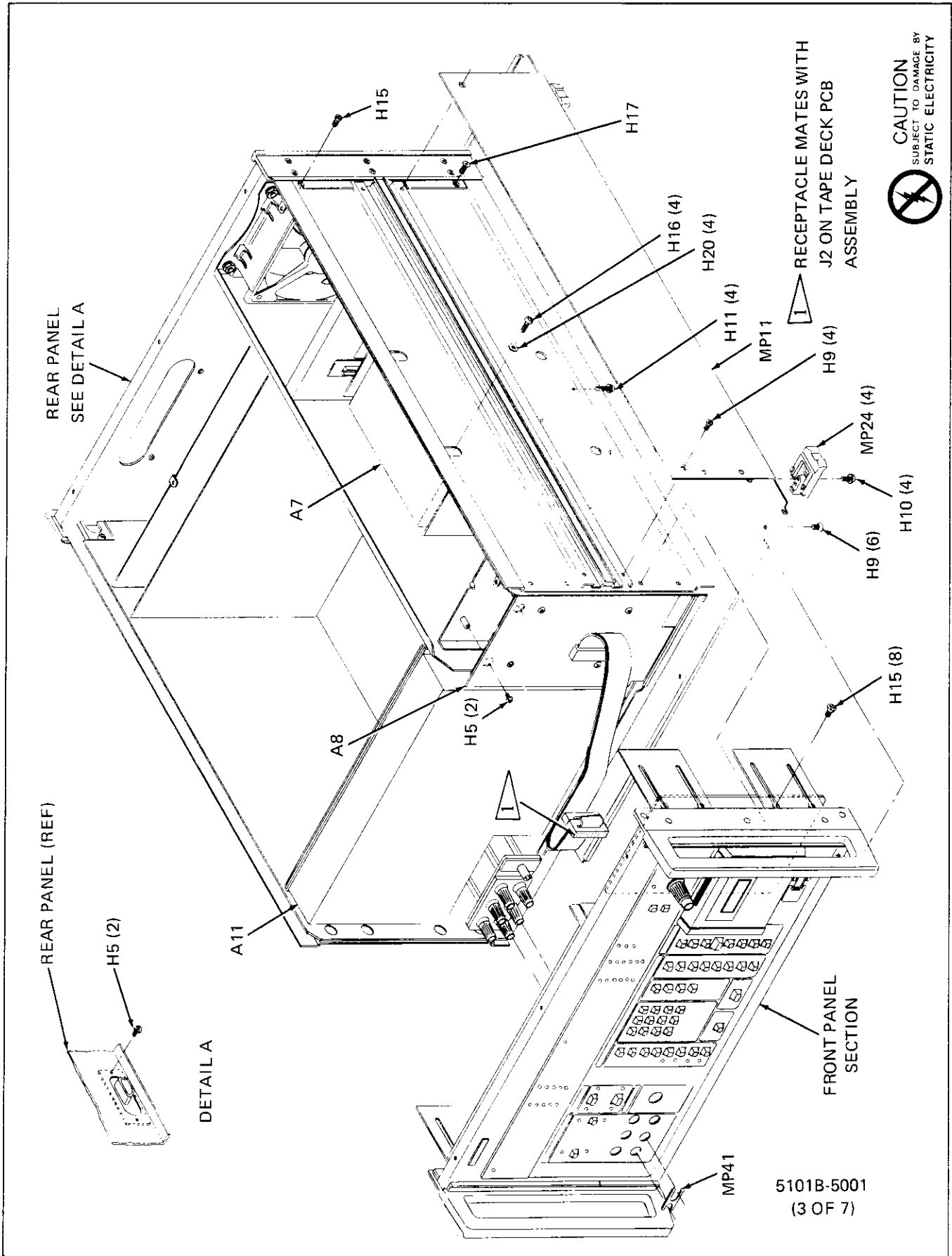

Figure 5-2. Final Assembly 5101B (cont)

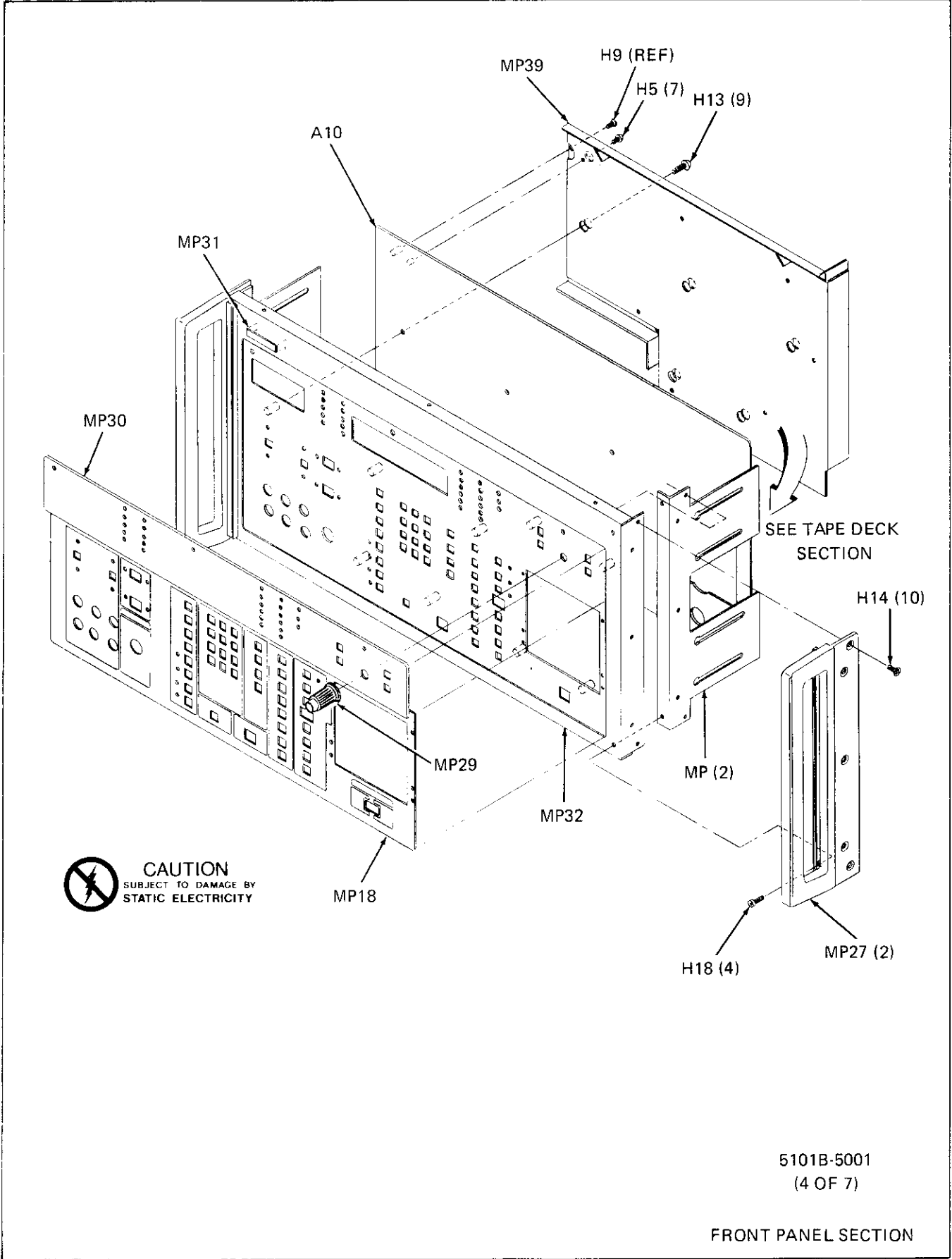
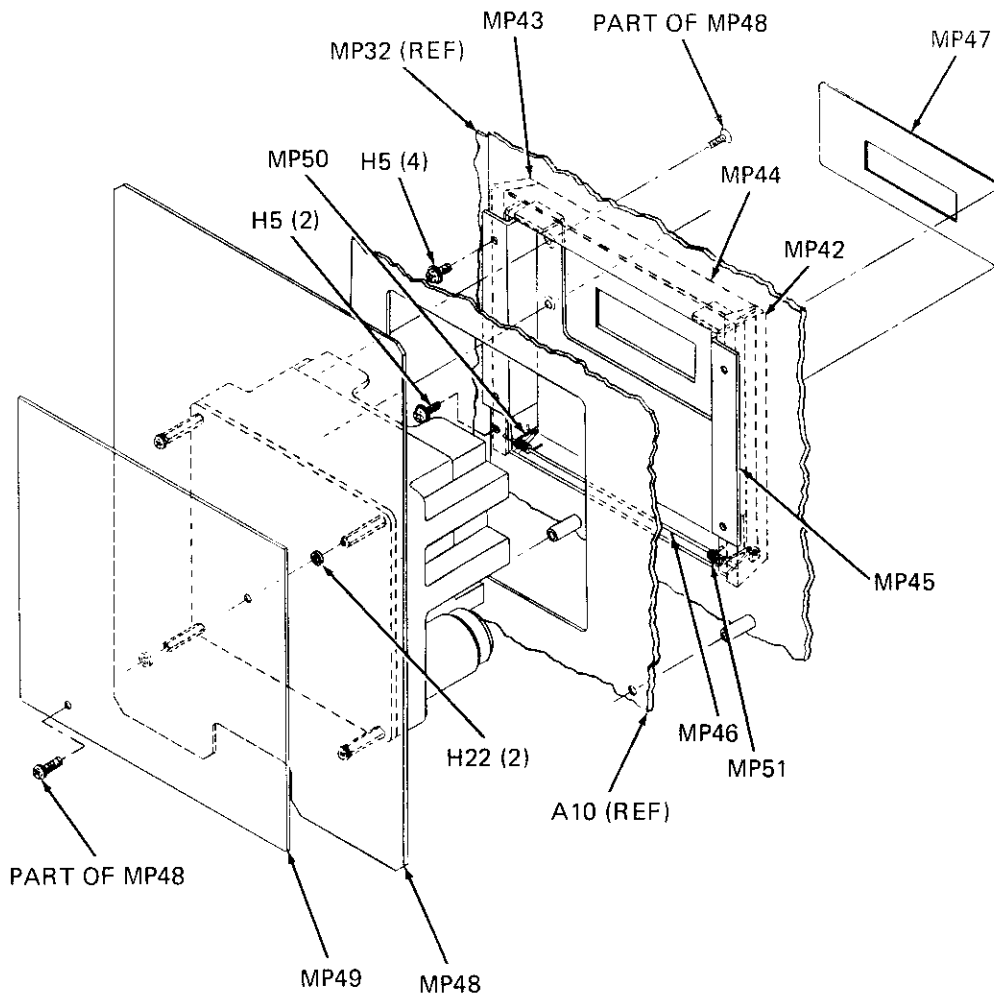

Figure 5-2. Final Assembly 5101B (cont)



5101B-5001 (5 OF 7)
TAPE DECK SECTION

Figure 5-2. Final Assembly 5101B (cont)

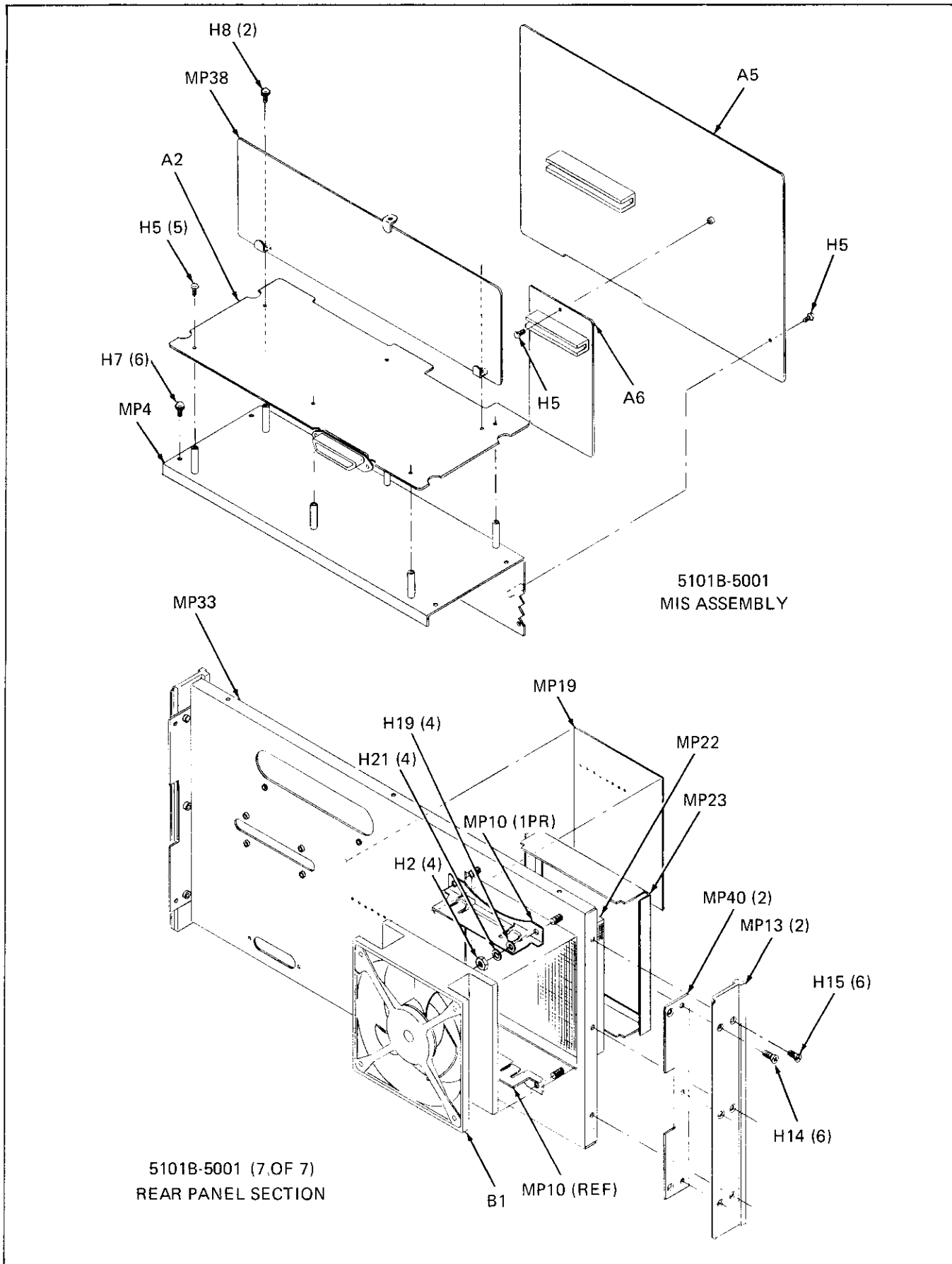

Figure 5-2. Final Assembly 5101B (cont)

Table 5-3. Final Assembly 5102B

REF DES	DESCRIPTION	FLUKE STOCK NO.	MFG SPLY CODE	MFG PART NO. OR TYPE	TOT QTY	REC QTY	NOTE
	FINAL ASSEMBLY FIGURE 5-3 (5102B-T&B/5001)	5102B					
A1	MAIN MOTHER PCB ASSEMBLY	420315	89536	420315	1		
A2	MIS MOTHER PCB ASSEMBLY	455725	89536	455725	1		
A3	POWER SUPPLY MOTHER PCB ASSEMBLY	433003	89536	433003	1		
A4	DIAGONAL BUS PCB ASSEMBLY	420281	89536	420281	1		
A5	MAIN INTERCONNECT PCB ASSEMBLY	420299	89536	420299	1		
A6	MIS INTERCONNECT PCB ASSEMBLY	420307	89536	420307	1		
A7	POWER TRANSFORMER ASSEMBLY (50-400HZ)	441048	89536	441048	1		
A7A1	FORWARD TRANSFORMER TERM PCB ASSEMBLY	ORDER	NEXT	HIGHER ASSEMBLY A7	1		
A7A2	AFT TRANSFORMER TERM PCB ASSEMBLY	ORDER	NEXT	HIGHER ASSEMBLY A7	1		
A8	POWER SUPPLY INTERCONNECT PCB ASSEMBLY	457226	89536	457226	1		
A9	⊗ POWER SUPPLY REGULATOR PCB ASSEMBLY	458398	89536	458398	1		
A10	⊗ FRONT PANEL PCB ASSEMBLY	458406	89536	458406	1		
A10A1	DISPLAY PCB ASSEMBLY	456004	89536	456004	1		
A11	⊗ RANGING PCB ASSEMBLY	458414	89536	458414	1		
A14	⊗ ANALOG CONTROL PCB ASSEMBLY	457705	89536	457705	1		
A15	⊗ DIGITAL-TO-ANALOG CONVERTER PCB ASSY.	458422	89536	458422	1		
A16	EXTENDED HI VOLTAGE OUTPUT PCB ASSEMBLY	514976	89536	514976	1		
A16A1	⊗ HI VOLTAGE CONTROL PCB ASSEMBLY	ORDER	NEXT	HIGHER ASSEMBLY A16	1		
A17	⊗ POWER AMP PCB ASSEMBLY	458448	89536	458448	1		
A17A1	POWER TRANSISTOR PCB ASSEMBLY	438606	89536	438606	1		
A18	⊗ OSCILLATOR PCB ASSEMBLY	458455	89536	458455	1		
A19	⊗ ISOLATOR PCB ASSEMBLY	455832	89536	455832	1		
A20	⊗ CONTROLLER PCB ASSEMBLY	477083	89536	477083	1		
A21	⊗ PROM-ROM-RAM PCB ASSY. (5100B, 5102B)	522821	89536	522821	1		
	⊗ PROM-ROM-RAM PCB ASSY. (5101B)	522854	89536	522854	1		
B1	FAN, MUFFIN VENTURI, 125V 14W	103374	89536	103374	1		
C32	CAP, MICA, 22 PF +/-5%, 500V	148551	72136	DM15E220J	1		1
H1	NUT, HEX, 6-32	110569	89536	110569	2		
H2	NUT, HEX 10-32	110536	73734	8011-NP	4		
H3	SCREW, PHP, 2-56 X 1/4	149534	89536	149534	2		
H4	SCREW, SEMS 4-40 X 1/4	185918	89536	185918	4		
H5	SCREW, PHP, 5-48 X 1/4	129890	73734	19022	53		
H6	SCREW, PHP, SEMS, 4-40 X 3/8	281196	89536	281196	2		
H7	SCREW, SEMS, 6-32 X 1/4	178533	89536	31	25		
H8	SCREW, PHP, 6-32 X 1/4	152140	89536	152140	2		
H9	SCREW, FH 6/08F, 6-32X1/4	320093	89536	320093	16		
H10	SCREW, SEMS, 6-32 X 1/2	177030	89536	177030	10		
H11	SCREW, SEMS, 6-32 X 5/8	272591	89536	272591	4		
H12	SCREW, PHP, 6-32 X 5/16	152157	89536	152157	2		
H13	SCREW, PHP, 6-32 X 7/16	362954	89536	362954	9		
H14	SCREW, PHP, 8-32 X 3/8	114116	73734	18264	16		
H15	SCREW, FH, 6-32 X 5/16	281725	73734	18263	16		
H16	SCREW, ANTI-TURN, 8-32 X 5/16	460428	89536	460428	4		
H17	SCREW, FH, 8-32 X 3/8	114116	73734	18264	3		
H18	SCREW, CAP, 8-32	448431	89536	448431	12		
H19	WASHER, FLAT, .20 X 10	110262	73734	AN960-10L	4		

Table 5-3. Final Assembly 5102B (cont)

REF DES	DESCRIPTION	FLUKE STOCK NO.	MFG SPLY CODE	MFG PART NO. OR TYPE	TOT QTY	REC QTY	NOTE
H20	WASHER, FLAT, .170 ID	110288	73734	97425	6		
H21	WASHER, INT LK, #10	110312	73734	99406	4		
H22	SCREW, RHP, 3-48 X 3/16	114959	89536	114959	1		
H23	SCREW, RHP, 3-48 X 3/16	448431	89536	448431	12		
H24	WASHER, #8, .171 ID	474650	89536	474650	12		
H25	SCREW, PHP, 4-24 X 3/8	183574	89536	183574	16		
H26	SCREW, 1 3/4 IN. LONG	474031	89536	474031	4		
H27	SCREW, FHP, 8-32 X 7/16	306159	89536	306159	8		
H28	SCREW, FHP, 8-32 X 5/8	184994	89536	184994	5		
MP1	BRACKET, CAP MOUNT	426197	89536	426197	1		
MP3	BRACKET, CARD GUIDE	468223	89536	468223	1		
MP4	BRACKET, MIS MTG	468207	89536	468207	1		
MP5	BULKHEAD, FRONT	468173	89536	468173	1		
MP6	CARD PULLER, ACCESSORY	170951	89536	170951	1		
MP7	CASE, GLASS FIBER	461749	89536	461749	1		
MP8	CHASSIS, LEFT SIDE	468363	89536	468363	1		
MP9	CHASSIS, RIGHT SIDE	468355	89536	468355	1		
MP10	CLIP, MTG	422535	82877	271016	2		
MP11	CHASSIS, BOTTOM	468181	89536	468181	1		
MP12	COVER, INNER	468199	89536	468199	1		
MP13	CORNER, REAR PLATE	468397	89536	468397	2		
MP14	PLATE, CONN COVER	426866	89536	426866	1		
MP15	DECAL, COVER (LOGO)	469080	89536	469080	1		
MP16	PANEL BRACKET, (FRONT MOUNTING)	468215	89536	468215	2		
MP17	PANEL SLIDE, (FRONT BRACKET)	468389	89536	468389	2		
MP18	DECAL, FRONT PANEL	429290	89536	429290	1		
MP19	DECAL, REAR PANEL	455683	89536	455683	1		
MP20	FOOT, REAR CASE	468348	89536	468348	4		
MP21	DORCAS, PLASTIC	421776	89536	421776	17		
MP22	FILTER ELEMENT	422543	82877	271018	1		
MP23	FRAME, FILTER	421750	89536	421720	1		
MP24	VINYL PLASTIC ENVELOPE	474056	89536	474056	1		
MP25	GROMMET, RUBBER 5/16	380782	77969	68	2		
MP26	CASE BAR	469072	89536	469072	4		
MP27	COVER, INNER INSULATOR	469098	89536	469098	1		
MP28	HOLDER, COMPONENT (RUBBER)	104794	98159	2829-115-3	1		
MP29	KNOB ASSY, FRONT PANEL	341446	89536	341446	1		
MP30	LENS DISPLAY, FRONT	429308	89536	429308	1		
MP31	NAMEPLATE, INTERIOR PANEL	393975	89536	393975	1		
MP32	PANEL, FRONT	522888	89536	522888	1		
MP33	PANEL, REAR	469031	89536	469031	1		
MP34	PARTITION, POWER SUPPLY	421693	89536	431693	1		
MP35	PLATE, ACCESS	426502	89536	426502	1		
MP36	GUIDE, PLATE (LO FREQ. XFMR)	425124	89536	425124	1		
MP37	PLATE, MIS BUS CONN	426841	89536	426841	2		
MP38	SHIELD, MIS PCB	420141	89536	420141	1		
MP39	SHIELD, PARTITION	426221	89536	426221	1		
MP40	SHIELD, POWER SUPPLY	455634	89536	455634	1		
MP41	POST, SHRTNG LINK, BRASS/GOLD	190728	24655	0938-9503	1		1
MP42	STANDOFF, NYLON INSUL, TAPPED	104174	89536	104174	2		

Table 5-3. Final Assembly 5102B (cont)

REF DES	DESCRIPTION	FLUKE STOCK NO.	MFG SPLY CODE	MFG PART NO. OR TYPE	TOT QTY	REC QTY	N O T E
MP43	RETAINER, RIGHT	469932	89536	469932	1		
MP44	RETAINER, LEFT	469924	89536	469924	1		
MP45	SCREEN, FRONT EXHAUST	468330	89536	468330	1		
MP46	SCREEN, REAR EXHAUST	468322	89536	468322	1		
MP47	SPACER, NYLON	474023	89536	474023	4		
MP48	GROMMET, (.40 FT)	435974	89536	435974	1		
P14	CABLE, FLAT, W/16-PIN CONN	380576	89536	380576	2		
P15	CABLE, FLAT, W/16-PIN CONN	380576	89536	380576	REF		
TM1	INSTRUCTION MANUAL (NOT SHOWN)	522987	89536	522987	1		
TM2	OPERATOR'S MANUAL, (NOT SHOWN)	523100	89536	523100	1		
W1	CORDSET, 3-WIRE (NOT SHOWN)	363481	89536	363481	1		
	RECOMMENDED SPARE PARTS KIT	530972	89536	530972	AR		
	1	ADDED IN TEST ON ALL PCB ASSEMBLY AS NEEDED.					

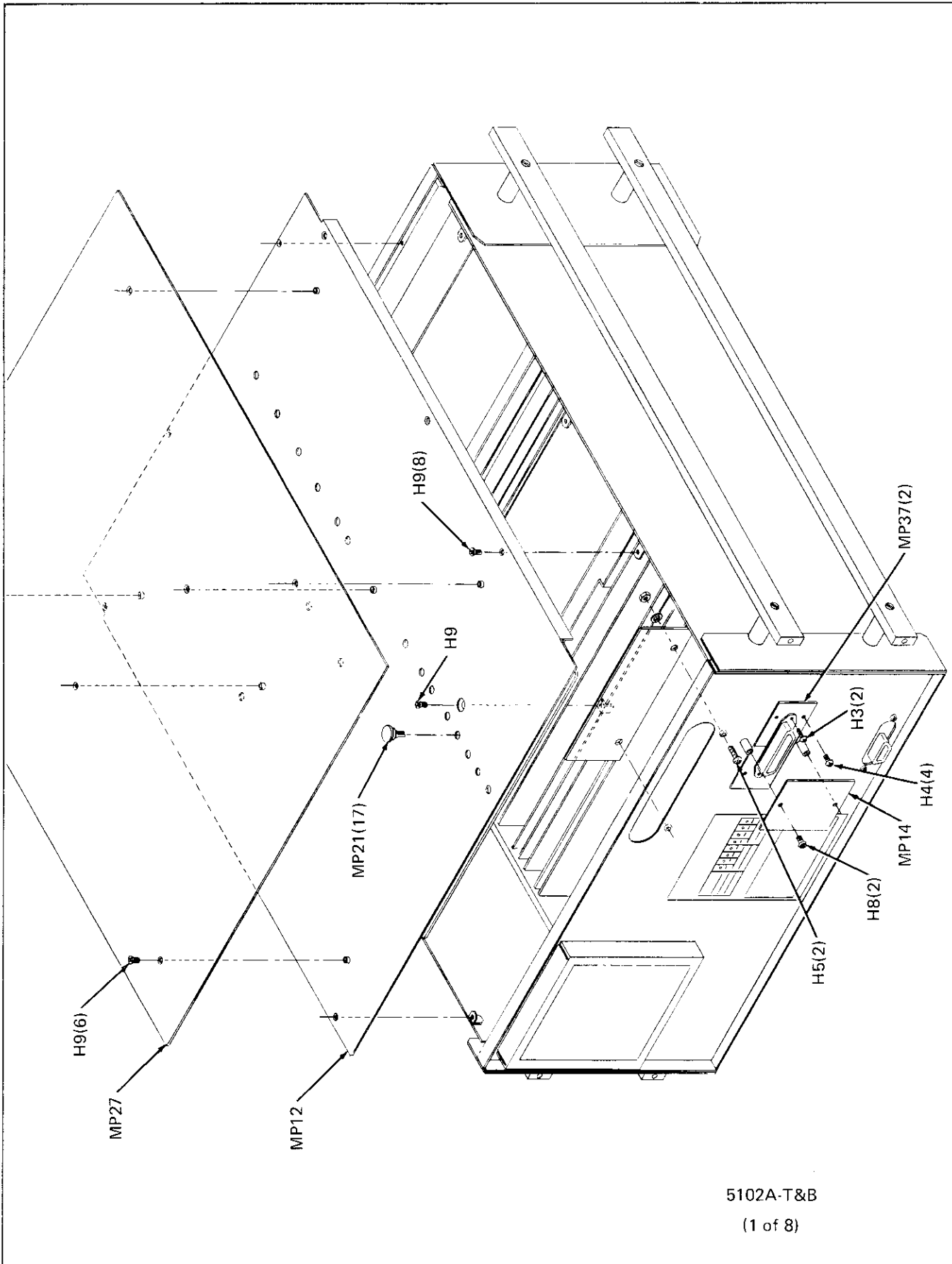

5102A-T&B
(1 of 8)

Figure 5-3. Final Assembly 5102B

 CAUTION
SUBJECT TO DAMAGE BY
STATIC ELECTRICITY

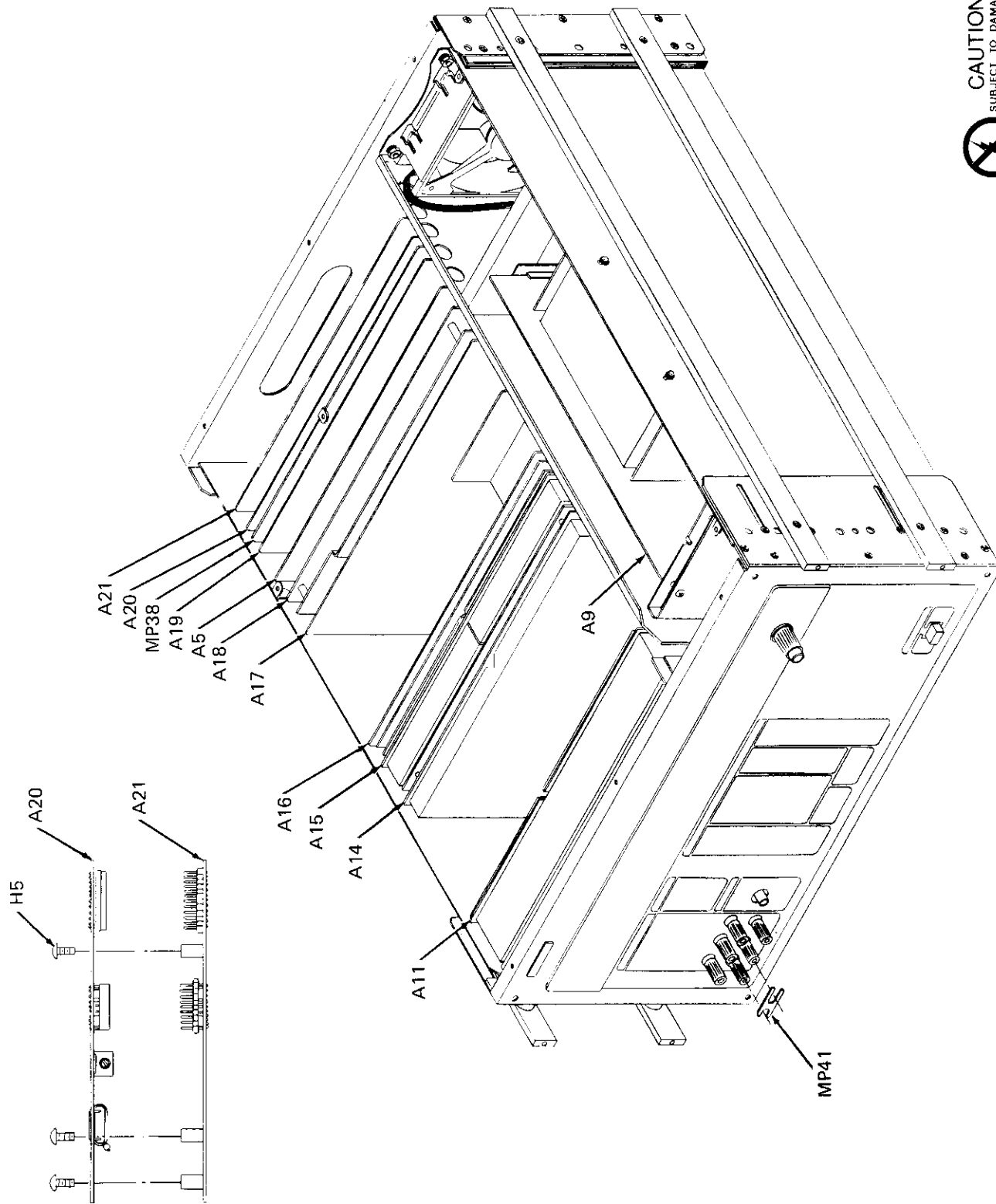

5102B-5001
(2 of 8)

Figure 5-3. Final Assembly 5102B (cont)

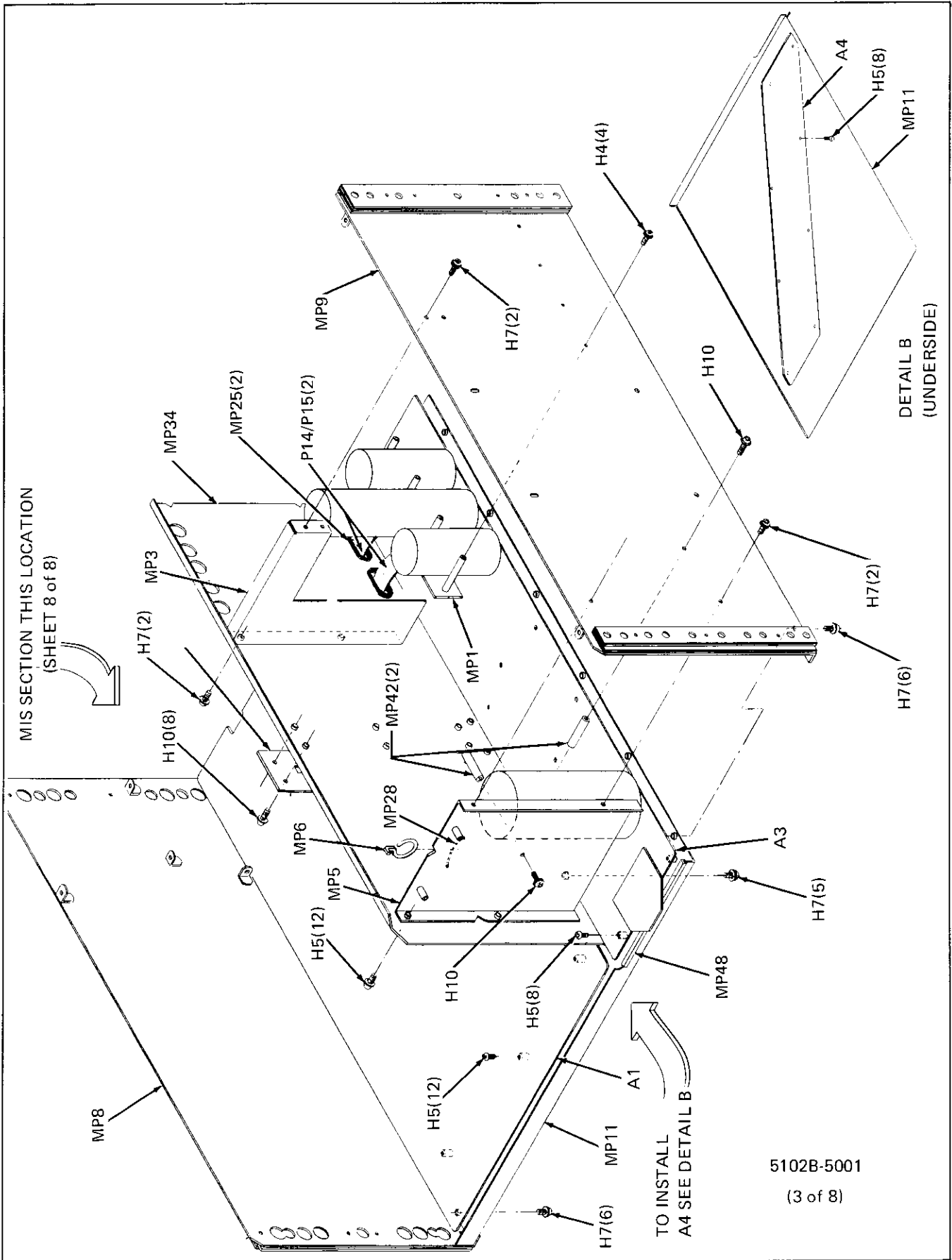

Figure 5-3. Final Assembly 5101B (cont)

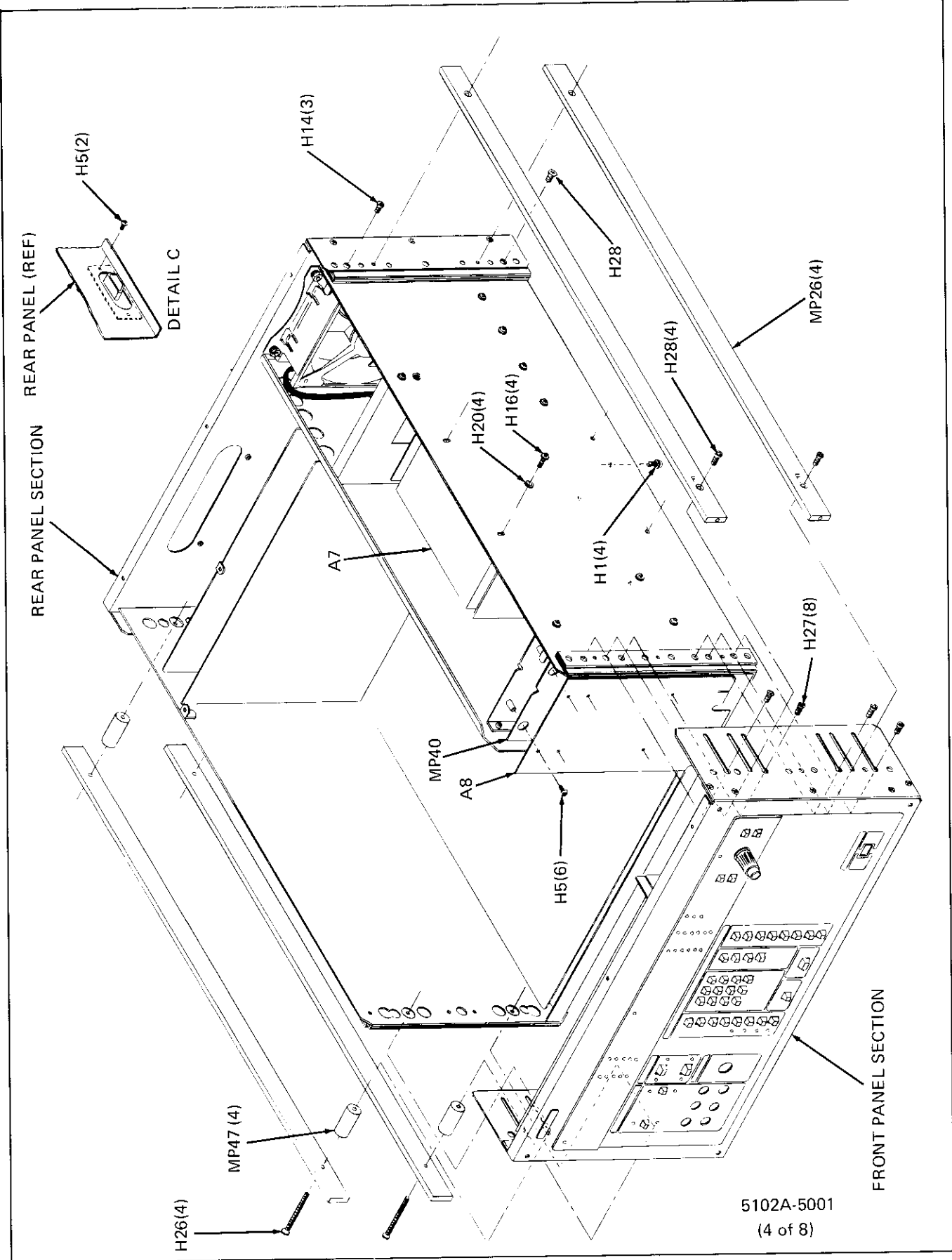

Figure 5-3. Final Assembly 5102B (cont)

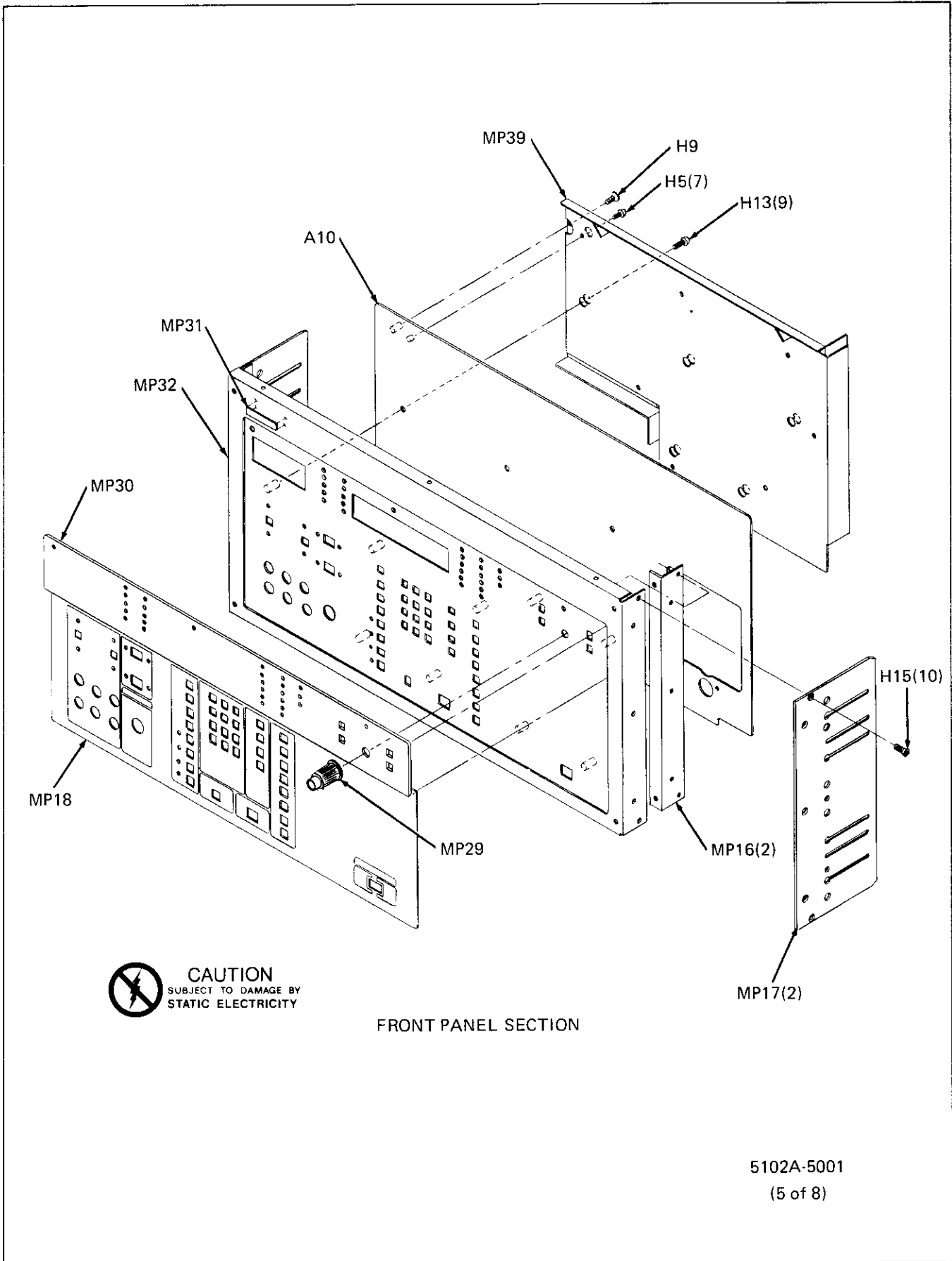
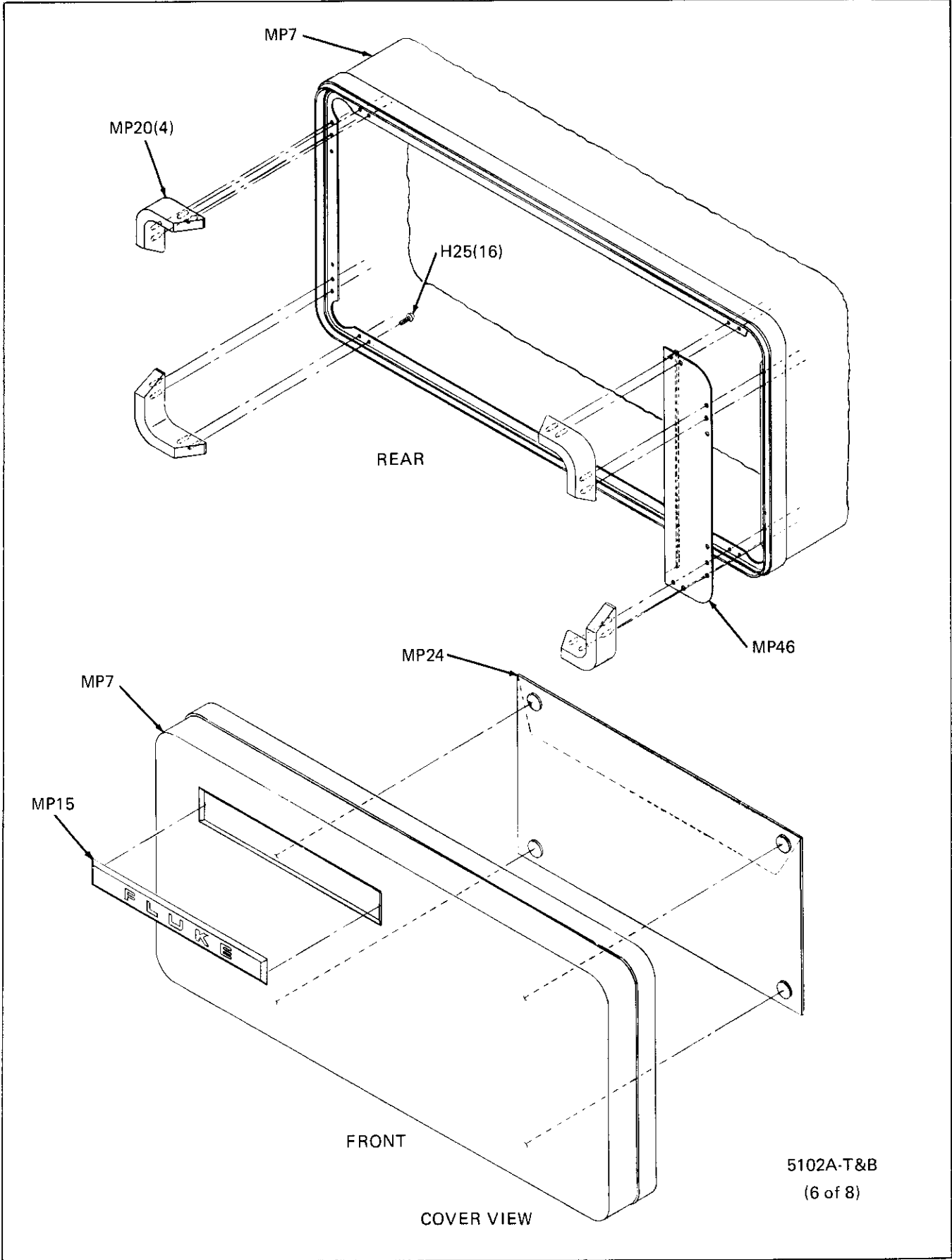

Figure 5-3. Final Assembly 5102B (cont)



5102A-T&B
(6 of 8)

Figure 5-3. Final Assembly 5102B (cont)

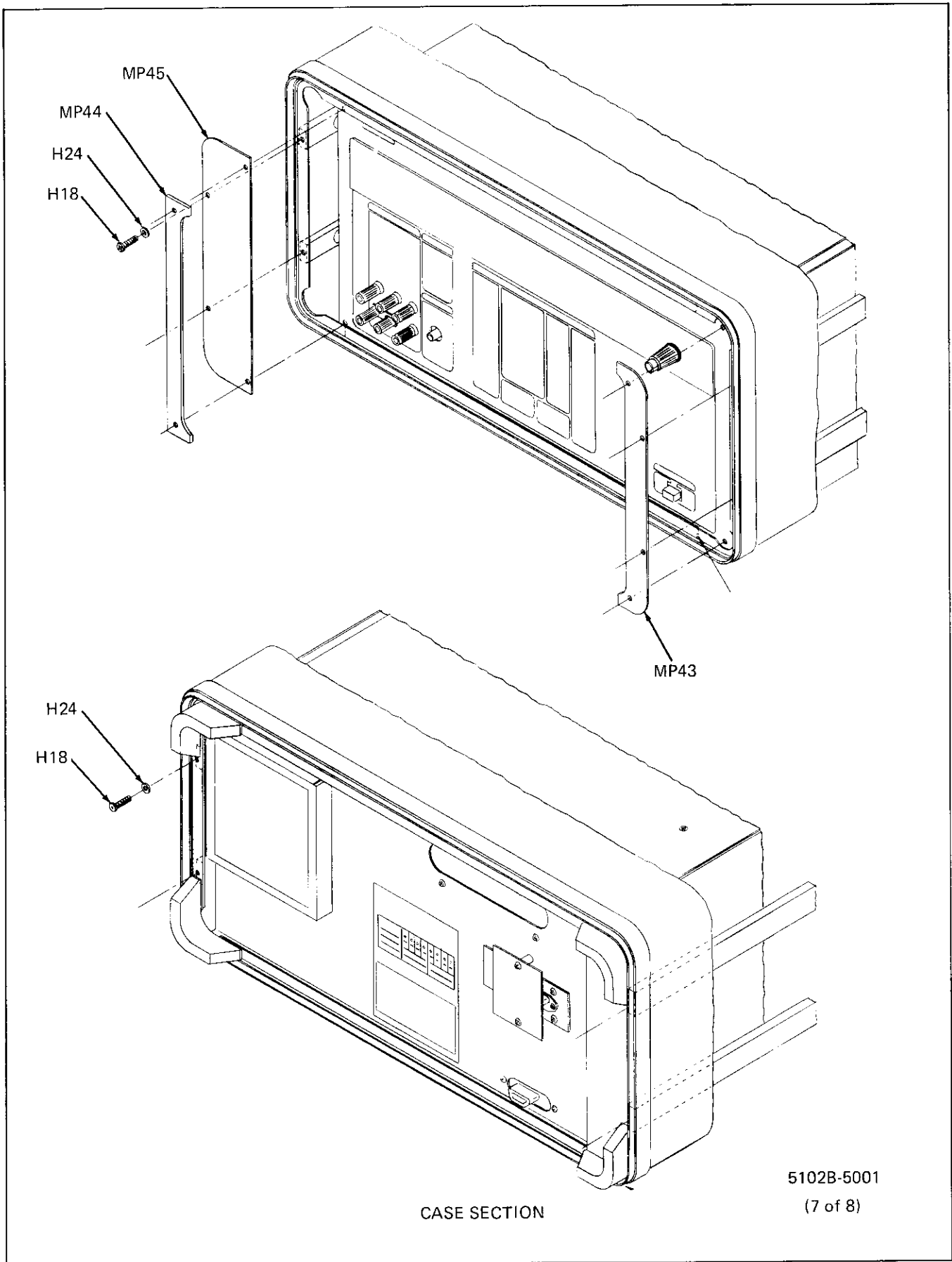
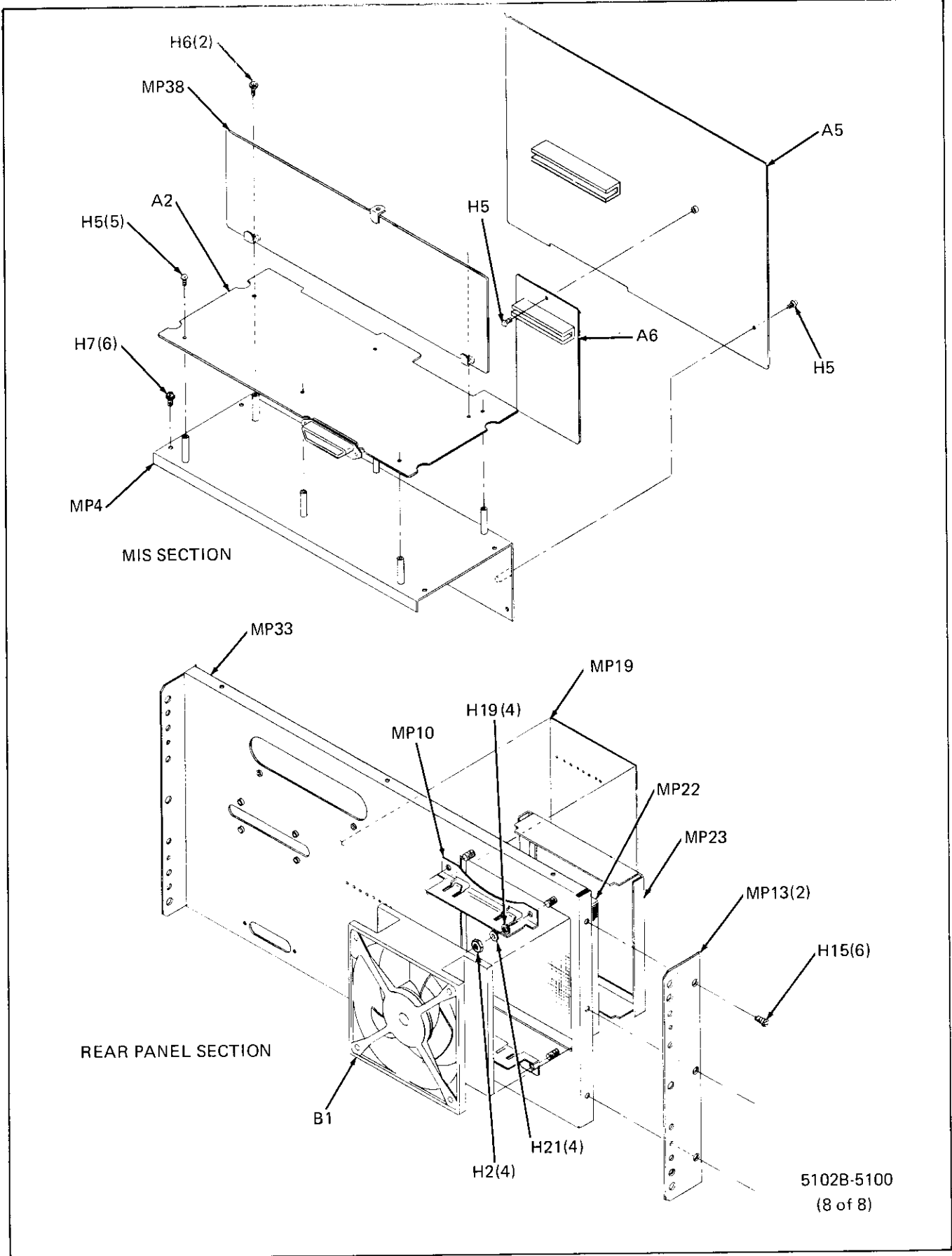

Figure 5-3. Final Assembly 5102B (cont)



5102B-5100
(8 of 8)

Figure 5-3. Final Assembly 5102B (cont)

Table 5-4. A1 Main Motherboard PCB Assembly

REF DES	DESCRIPTION	FLUKE STOCK NO.	MFG SPLY CODE	MFG PART NO. OR TYPE	TOT QTY	REC QTY	NO TE
A1	MAIN MOTHERBOARD PCB ASSEMBLY FIGURE 5-4 (5100A-4001T)	420315	89536	420315	REF		
C1	CAP, ELECT, 45,000 UF -10/+75%, 25V	446864	56289	36DX453G025BF2A	2	1	
C2	CAP, ELECT, 45,000 UF -10/+75%, 25V	446864	56289	36DX453G025BF2A	REF		
H1	SCREW, RHP, 2-56 X 1/4 (TO J43, J73)	149534	89536	149534	6		
H2	SCREW, FHP, 2-56 X 3/8 (TO J43, J73)	146803	73734	22204	2		
H3	SCREW, PHP, 10-32 X 1/4	218941	73734	19082	4		
H4	SCREW, PHP, 6-32 X 1/2 (TO MP3)	177030	89536	177030	8		
J2	CONNECTOR, CABLE, RIBBON	272450	02660	57-40140	1		
J23	CONNECTOR, RECEPTACLE	422550	00779	25834070	17		
J41	CONNECTOR, RECEPTACLE	422550	00779	25834070	REF		
J42	CONNECTOR, RECEPTACLE	422550	00779	25834070	REF		
J43	CONNECTOR, HI-VOLTAGE, FE	442889	91637	G16SAB	2		
J44	CONNECTOR, COAX	423020	98291	52-052-0000	4		
J51	CONNECTOR, RECEPTACLE	422550	00779	25834070	REF		
J52	CONNECTOR, RECEPTACLE	422550	00779	25834070	REF		
J53	CONNECTOR, COAX	423020	98291	52-052-0000	REF		
J54	CONNECTOR, COAX	423020	98291	52-052-0000	REF		
J61	CONNECTOR, RECEPTACLE	422550	00779	25834070	REF		
J62	CONNECTOR, RECEPTACLE	422550	00779	25834070	REF		
J63	CONNECTOR, COAX	423020	98291	52-052-0000	REF		
J71	CONNECTOR, RECEPTACLE	422550	00779	25834070	REF		
J72	CONNECTOR, RECEPTACLE	422550	00779	25834070	REF		
J73	CONNECTOR, HI-VOLTAGE, FE	442889	91637	G16SAB	REF		
J81	CONNECTOR, RECEPTACLE	422550	00779	25834070	REF		
J82	CONNECTOR, RECEPTACLE	422550	00779	25834070	REF		
J91	CONNECTOR, RECEPTACLE	422550	00779	25834070	REF		
J92	CONNECTOR, RECEPTACLE	422550	00779	25834070	REF		
J111	CONNECTOR, RECEPTACLE	422550	00779	25834070	REF		
J112	CONNECTOR, RECEPTACLE	422550	00779	25834070	REF		
J121	CONNECTOR, RECEPTACLE	422550	00779	25834070	REF		
J122	CONNECTOR, RECEPTACLE	422550	00779	25834070	REF		
MP1	SHIELD, MAIN MOTHERBOARD (NOT SHOWN)	425686	89536	425686	1		
MP2	PLATE, ANALOG, CONNECTOR (TO J2)	425694	89536	425694	1		
MP3	PLATE, CAP, MTG	425181	89536	425181	1		
MP4	ANGLE, HIGH VOLTAGE, CONN (TO J43, J73)	445015	89536	445015	2		
MP5	INSERT, POLAR, KEY PLUG	293498	00779	530030-1	9		
MP6	LUG, SOLDER (NOT SHOWN)	101014	79963	123	2		
MP7	LUG, SOLDER (NOT SHOWN)	101048	79963	46	2		
MP8	STANDOFF, INSULATED, NYLON, 6-32	446302	89536	446302	4		
R1	RES, COMP, 680 +/-5%, 1W	180349	01121	GB6815	2		
R2	RES, COMP, 680 +/-5%, 1W	180349	01121	GB6815	REF		
W1	CABLE, ASSY, HIGH VOLTAGE (NOT SHOWN)	426924	89536	426924	1		
W2	CABLE ASSEMBLY, DC, ATTN. (NOT SHOWN)	432823	89536	432823	1		
WT1	CABLE, TIE (NOT SHOWN)	172080	06383	SST-1M	3		
XP14	SOCKET, IC, 16-PIN	387324	71785	133-59-02-062	2		
XP15	SOCKET, IC, 16-PIN	387324	71785	133-59-02-062	REF		

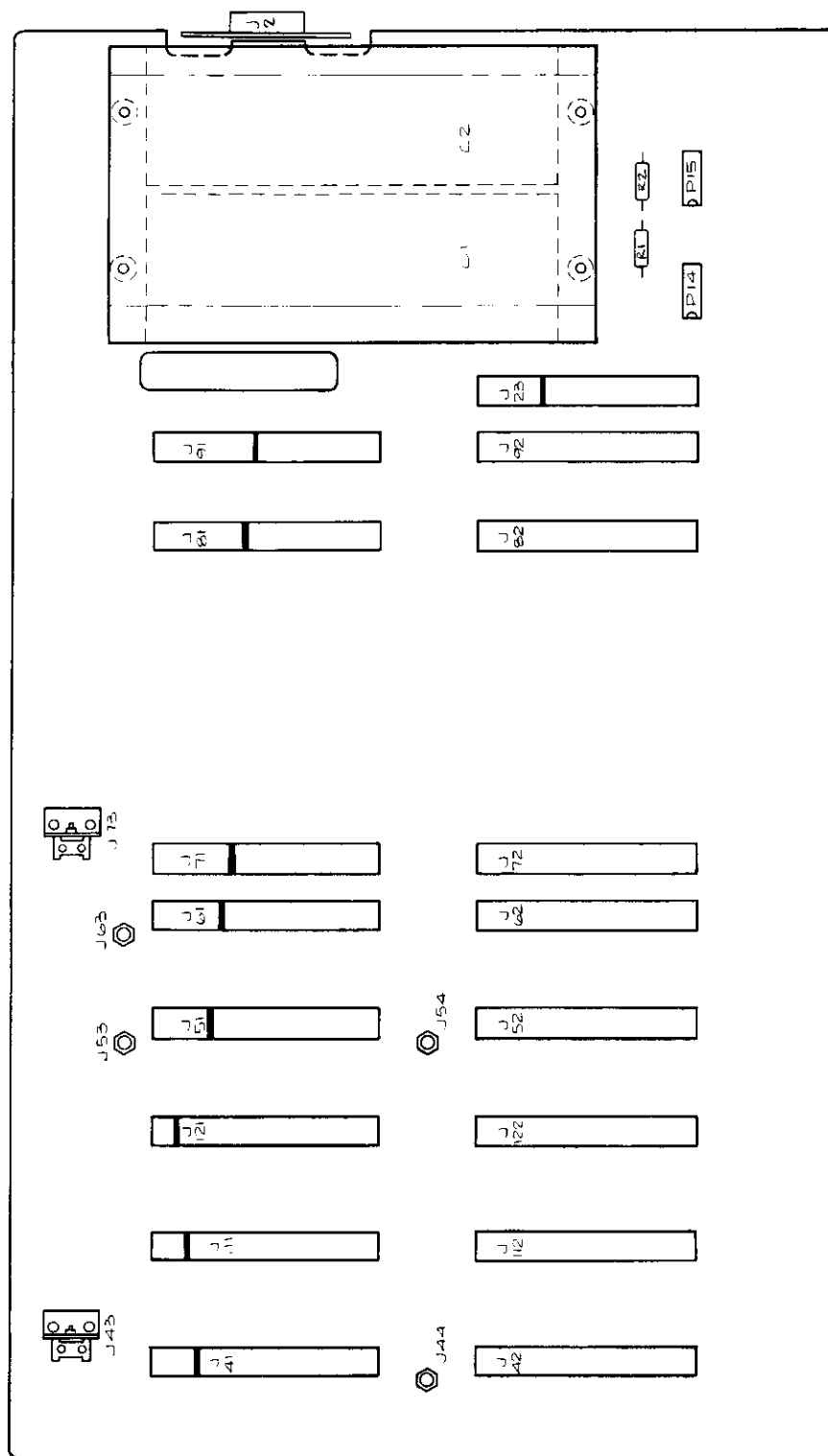

5100A-1601

Figure 5-4. A1 Main Motherboard PCB Assembly

Table 5-5. A2 MIS Motherboard PCB Assembly

REF DES	DESCRIPTION	FLUKE STOCK NO.	MFG SPLY CODE	MFG PART NO. OR TYPE	TOT QTY	REC QTY	N O T E
A2	MIS MOTHERBOARD PCB ASSEMBLY FIGURE 5-5 (5100A-4002T)	455725	89536	455725			REF
J4	CONNECTOR, FEMALE	158469	02660	57-40360		1	
J25	CONNECTOR, RECEPTACLE	422550	00779	2-583407-0		6	
J28	CONNECTOR, RECEPTACLE	422550	00779	2-583407-0			REF
J29	CONNECTOR, RECEPTACLE	422550	00779	2-583407-0			REF
J30	CONNECTOR, RECEPTACLE	422550	00779	2-583407-0			REF
J31	CONNECTOR, RECEPTACLE	422550	00779	2-583407-0			REF
J32	CONNECTOR, RECEPTACLE	422550	00779	2-583407-0			REF
MP1	INSERT, POLARIZING KEY	293498	00779	530030-1		5	

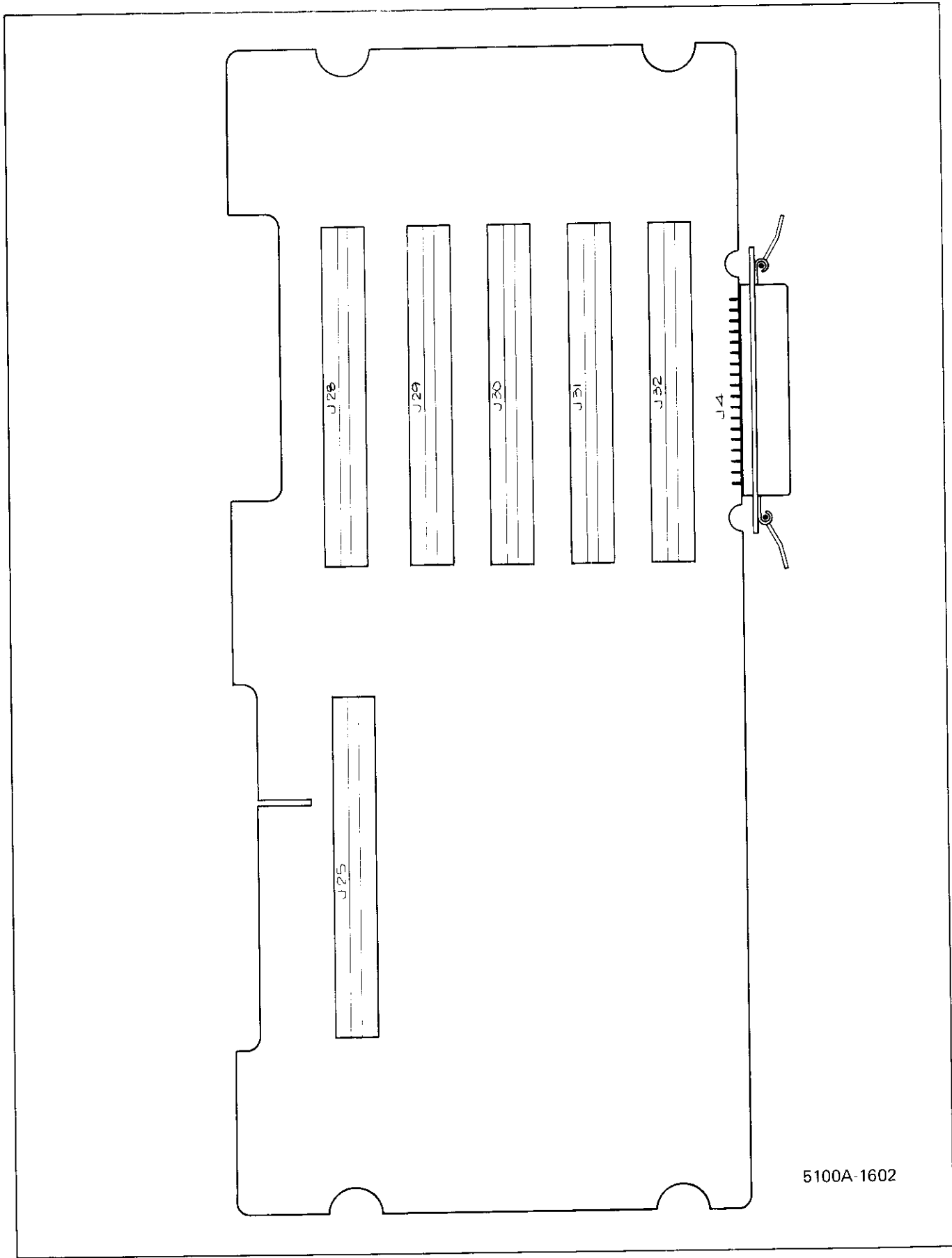

5100A-1602

Figure 5-5. A2 MIS Motherboard PCB Assembly

Table 5-6. A3 Power Supply Motherboard PCB Assembly

REF DES	DESCRIPTION	FLUKE STOCK NO.	MFG SPLY CODE	MFG PART NO. OR TYPE	TOT QTY	REC QTY	NO TE
A3	PWR SUP MOTHERBOARD PCB ASSEMBLY FIGURE 5-6 (5100A-4003T)	433003	89536	433003		REF	
BP1	BINDING POST, GROUNDING	102707	20584	1444	1		
C1	CAP, ELECT, 1700 UF -10/+75%, 100V	423541	56289	36D172G100AB2B	2	1	
C2	CAP, ELECT, 1700 UF -10/+75%, 100V	423541	56289	36D172G100AB2B		REF	
C7	CAP, ELECT, 34,000 UF -10/+100%, 15V	423533	56289	36DX343G015AF2B	1	1	
C9	CAP, ELECT, 750 UF -10/+75%, 50V	424366	56289	601D757G005FE4	2	1	
C10	CAP, ELECT, 750 UF -10/+75%, 50V	424366	56289	601D757G005FE4		REF	
C11	CAP, ELECT, 50,000 UF -10/+100%, 15V	423525	56289	36DX503G015BC2B	1	1	
F1	FUSE, MDX, SLO-BLO	109181	71400	MOX2	1		5
H1	NUT, HEX, 4-40	110635	89536	110635	2		
H2	NUT, HEX, 28-1/4	110619	89536	110619	1		
H3	SCREW, PHP	380626	89536	380626	2		
H4	SCREW, PHP, SENS, 6-32 X 1/4	178533	89536	178533	6		
H5	SCREW, PHP, 8-32 X 3/8	114124	89536	114124	8		
H6	WASHER, INT/LK #4	110403	89536	110403	3		
H7	WASHER, INT/LK #8	110320	89536	110320	8		
J1	CONNECTOR, BULKHEAD, RECEPTACLE	284166	82389	EAC301	1		
J11	CONNECTOR, RECEPTACLE, BD-EDGE	422550	00779	2-583407-0	2		
J12	CONNECTOR, RECEPTACLE, BD-EDGE	422550	00779	2-583407-0		REF	
J13	CONNECTOR, RECEPTACLE, BD-EDGE	408484	00779	583407-9	1		
J14	SOCKET, IC, DIL CONNECTOR	387324	71785	133-59-02-062	2		
J15	SOCKET, IC, DIL CONNECTOR	387324	71785	133-59-02-062		REF	
J16	CONNECTOR, RECEPTACLE, BD-EDGE	291930	00779	583650-6	1		
J17	CONNECTOR, RECEPTACLE, BD-EDGE	459883	89536	459883	1		
MP1	CAP, BINDING POST, KNURLED	102889	20584	1445	1		
MP2	BRACKET, FUSE LINE	425173	89536	425173	1		
MP3	INSERT, POLARIZING KEY	293498	00779	530030-1	5		
MP4	BRACKET, POWER SWITCH	425678	89536	425678	1		
MP5	LUG, TERMINAL, INTERLOCK	102566	79963	813	2		
MP6	INSULATOR	438564	89536	438564	1		
R1	RES, COMP, 18K +/-10%, 1W	109447	01121	GB1831	2		
R2	RES, COMP, 18K +/-10%, 1W	109447	01121	GB1831		REF	
R3	RES, CAR, 39K +/-5%, 1/4W	442400	80031	CR251-45P39KT	2		
R4	RES, CAR, 39K +/-5%, 1/4W	442400	80031	CR251-45P39KT		REF	
R7	RES, COMP, 820 +/-5%, 1W	266379	01121	GB8215	1		
R11	RES, COMP, 680 +/-5%, 1W	180349	01121	GB6815	1		
S1	SWITCH, DPDT, POWER	291526	89536	291526	1		
S4	PUSHBUTTON, SWITCH, GREEN	419747	89536	419747	1		
TP1	CABLE, TIE	381533	06383	PLT1M	6		
W1	CABLE ASSEMBLY, POWER AND FAN	426858	89536	426858	1		
W2	CORD SET, FAN	438424	89536	438424	1		
XF1	FUSEHOLDER	424416	89536	424416	1		

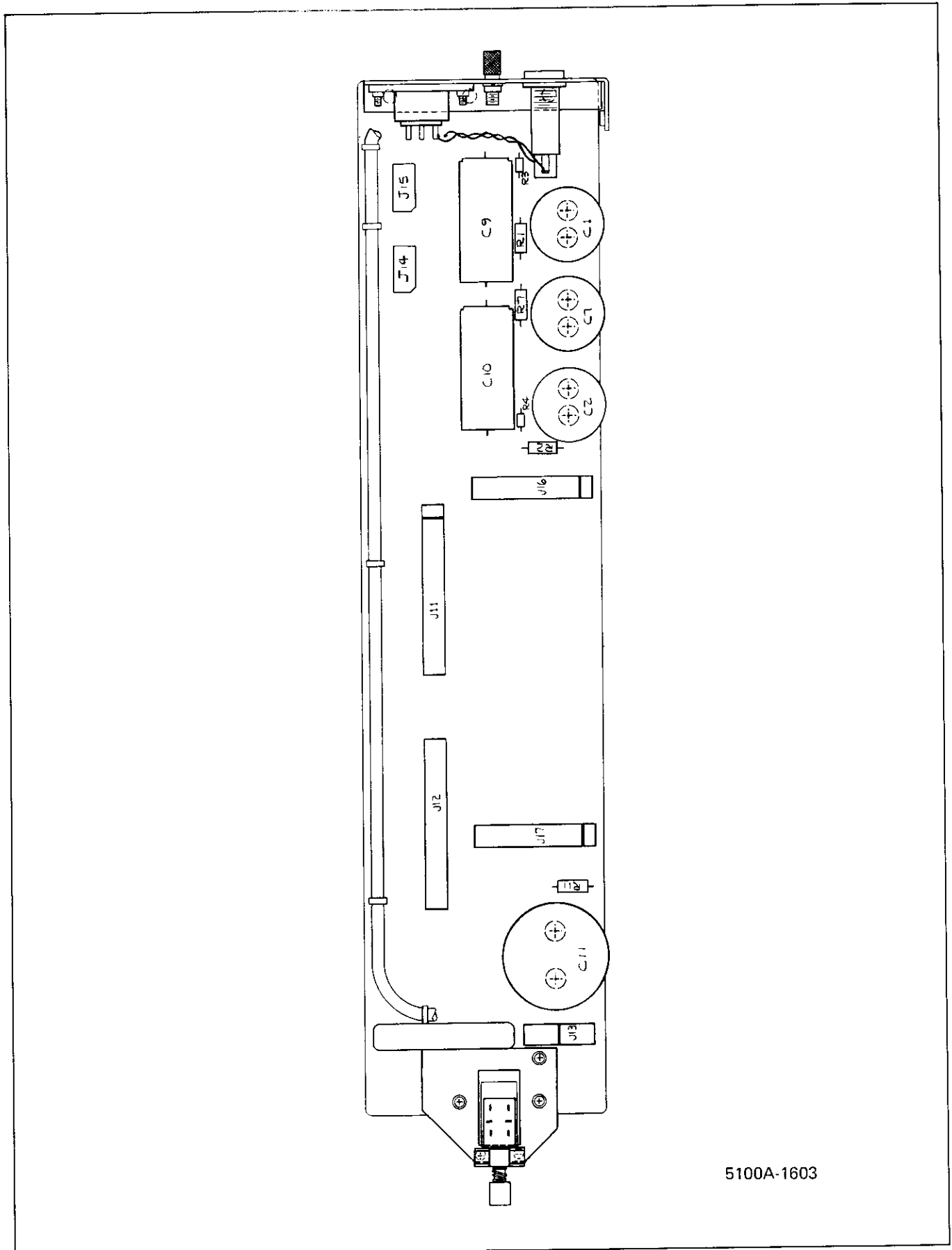

5100A-1603

Figure 5-6. A3 Power Supply Motherboard PCB Assembly

Table 5-7. A4 Interconnect PCB Assembly

REF DES	DESCRIPTION	FLUKE STOCK NO.	MFG SPLY CODE	MFG PART NO. OR TYPE	TOT QTY	REC QTY	NOTE
A4	INTERCONNECT PCB ASSEMBLY (NOT ILLUSTRATED) (5100A-4004)	420281	89536	420291			REF
J22	CONN, BOARD EDGE RECEPTACLE (ONE INSERT)	448050	00779	1-583407-6	1		
J27	CONN, BOARD EDGE RECEPTACLE (2 INSERTS)	291948	00779	583650-7	1		
MP1	INSERT, POLARIZING KEY	293498	00779	530030-1	3		
P1	PLUG, SNAP-IN	187799	82240	B-2328	6		

Table 5-8. A5 Main Interconnect PCB Assembly

REF DES	DESCRIPTION	FLUKE STOCK NO.	MFG SPLY CODE	MFG PART NO. OR TYPE	TOT QTY	REC QTY	NOTE
A5	MAIN INTERCONNECT PCB ASSEMBLY (NOT ILLUSTRATED) (5100A-4005)	420299	89536	420299			REF
MP1	INSERT, POLARIZING KEY	293498	00779	530030-1	1		
P24	CONNECTOR, PCB	422550	00779	2-583407-0	1		

Table 5-9. A6 Interconnect, MIS PCB Assembly

REF DES	DESCRIPTION	FLUKE STOCK NO.	MFG SPLY CODE	MFG PART NO. OR TYPE	TOT QTY	REC QTY	NOTE
A6	INTERCONNECT, MIS PCB ASSEMBLY (NOT ILLUSTRATED) (5100A-4006)	420307	89536	420307			REF
J26	CONNECTOR, RECEPTACLE (NOT SHOWN)	291948	00779	583650-7	1		

Table 5-10. A7 Power Transformer Assembly

REF DES	DESCRIPTION	FLUKE STOCK NO.	MFG SPLY CODE	MFG PART NO. OR TYPE	TOT QTY	REC QTY	NOTE
A7	POWER TRANSFORMER ASSEMBLY (NOT ILLUSTRATED) (5100A-6520)	441048	89536	441048			REF
A7A1	FWD XFMR TERM PCB ASSEMBLY FIGURE 5-7 (5100A-4011)	ORDER	NEXT	HIGHER LEVEL	1		
A7A2	AFT XFMR TERM PCB ASSEMBLY FIGURE 5-8 (5100A-4012)	ORDER	NEXT	HIGHER LEVEL	1		
T1	POWER TRANSFORMER	ORDER	NEXT	HIGHER LEVEL	1		

Table 5-11. A7A1 Forward Transformer Terminal PCB Assembly

REF DES	DESCRIPTION	FLUKE STOCK NO.	MFG SPLY CODE	MFG PART NO. OR TYPE	TOT QTY	REC QTY	NOTE
A7A1	FWD XFMR TERM PCB ASSEMBLY FIGURE 5-7 (5100A-4011)	ORDER	NEXT	HIGHER LEVEL			
C12	CAP, ELECT, 2200 UF -10/+100%, 25V	392720	25088	B41010/2200/25	2	1	
C13	CAP, ELECT, 2200 UF -10/+100%, 25V	392720	25088	B41010/2200/25	REF		
CR5	RECTIFIER, BRIDGE	296509	09423	FB200	1	1	
CR10	DIODE, RECTIFIER	331090	14099	3SM2	2	1	
CR11	DIODE, RECTIFIER	331090	14099	3SM2	REF		
CR16	DIODE, SI, RECTIFIER, 1 AMP	343491	01295	1N4003	2	1	
CR17	DIODE, SI, RECTIFIER, 1 AMP	343491	01295	1N4003	REF		
MP1	STRAP, RUBBER, MOUSETAIL	104794	98159	2829-115-3	2		
R9	RES, COMP, 4.3K +/-5%, 1/2W	403337	01121	EB4325	2		
R10	RES, COMP, 4.3K +/-5%, 1/2W	403337	01121	EB4325	REF		
RV2	VARIATOR, VOL VAR, RES	460394	89536	460394	1	1	
S1	SWITCH, SLIDE, DPDT	234278	89536	234278	3	1	
S2	SWITCH, SLIDE, DPDT	234278	89536	234278	REF		
S3	SWITCH, SLIDE, DPDT	234278	89536	234278	REF		

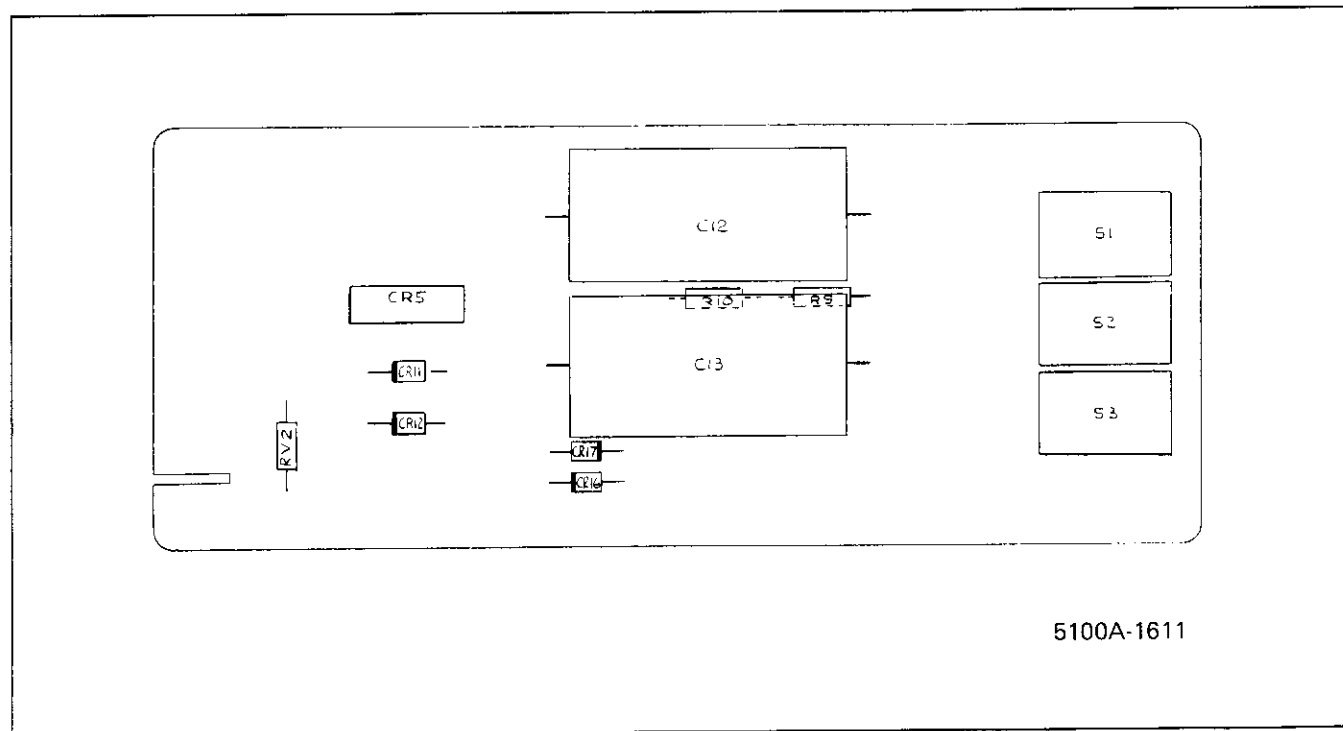

Figure 5-7. A7A1 Forward Transformer Terminal PCB Assembly

Table 5-12. A7A2 Aft Transformer Terminal PCB Assembly

REF DES	DESCRIPTION	FLUKE STOCK NO.	MFG SPLY CODE	MFG PART NO. OR TYPE	TOT QTY	REC QTY	NOTE
A7A2	AFT XFMR TERM PCB ASSEMBLY FIGURE 5-8 (5100A-4012)	ORDER	NEXT	HIGHER LEVEL			
C3	CAP, ELECT, 2100 UF -10/+100%, 35V	370742	25088	B41010/2100/40	2	1	
C4	CAP, ELECT, 2100 UF -10/+100%, 35V	370742	25088	B41010/2100/40	REF		
C8	CAP, ELECT, 2000 UF -10/+100%, 15V	364182	25088	B41010/2000/15	1	1	
CR1	RECTIFIER, BRIDGE	296509	21845	F903C-22	3	1	
CR2	RECTIFIER, BRIDGE	296509	21845	F903C-22	REF		
CR4	RECTIFIER, BRIDGE	296509	21845	F903C-22	REF		
CR6	DIODE, RECTIFIER	331090	14099	3SM2	8	2	
CR7	DIODE, RECTIFIER	331090	14099	3SM2	REF		
CR8	DIODE, RECTIFIER	331090	14099	3SM2	REF		
CR9	DIODE, RECTIFIER	331090	14099	3SM2	REF		
CR12	DIODE, RECTIFIER	331090	14099	3SM2	REF		
CR13	DIODE, RECTIFIER	331090	14099	3SM2	REF		
CR14	DIODE, RECTIFIER	331090	14099	3SM2	REF		
CR15	DIODE, RECTIFIER	331090	14099	3SM2	REF		
F1	FUSE, SLO-ACTING, 3 AMP	109280	71400	MDA3	2	1	
F2	FUSE, SLO-ACTING, 3 AMP	109280	71400	MDA3	REF		
MP1	STRAP, RUBBER, MOUSETAIL	104794	98159	2829-115-3	3		
R5	RES, COMP, 4.3K +/-5%, 1/2W	403337	01121	EB4325	3		
R6	RES, COMP, 4.3K +/-5%, 1/2W	403337	01121	EB4325	REF		
R8	RES, COMP, 4.3K +/-5%, 1/2W	403337	01121	EB4325	REF		
RV1	VARISTOR, VOL VAR, RES	460394	89536	460394	1	1	
XF1	FUSE CLIP	485219	11503	3529	4		
XF2	FUSE CLIP	485219	11503	3529	REF		

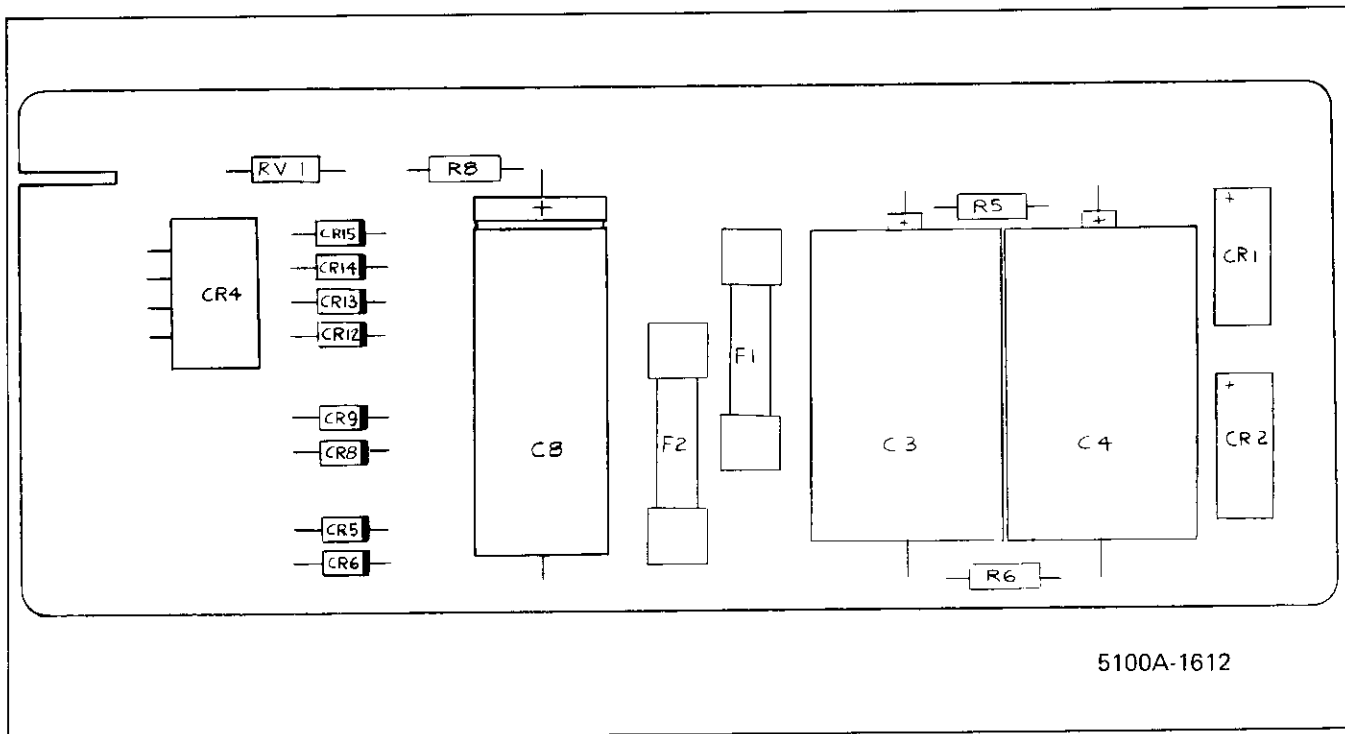

Figure 5-8. A7A2 Aft Transformer Terminal PCB Assembly

Table 5-13. A8 Power Supply Interconnect PCB Assembly

REF DES	DESCRIPTION	FLUKE STOCK NO.	MFG SPLY CODE	MFG PART NO. OR TYPE	TOT QTY	REC QTY	NOTE
A8	POWER SUPPLY INTERCONNECT PCB ASSEMBLY (NOT ILLUSTRATED) (5100A-4130)	457226	89536	457226	REF		
H1	SCREW, PHP, 4-40 X 1/4	129890	73734	19022	4		
J10	SOCKET, IC, 16-PIN	387324	71785	133-59-02-062	2		
J21	SOCKET, IC, 16-PIN	387324	71785	133-59-02-062	REF		
MP1	SHIELD	455643	89536	455643	1		

Table 5-14. A8 Tape Interface PCB Assembly

REF DES	DESCRIPTION	FLUKE STOCK NO.	MFG SPLY CODE	MFG PART NO. OR TYPE	TOT QTY	REC QTY	NOTE
A8	⊗ TAPE INTERFACE PCB ASSEMBLY FIGURE 5-9 (5101A-4130T) USED ON 5101B (STORAGE)	458794	89536	458794	REF		
C1	CAP, MYLAR, 0.1 UF +/-10%, 100V	393439	73445	C280MAH/A100K	2		
C2	CAP, MYLAR, 0.01 UF +/-10%, 250V	325548	73445	C280MAE/A10K	1		
C3	CAP, TA, 22 UF +/-20%, 15V	423012	56289	196D226X0015KA1	1		
C4	CAP, MYLAR, 0.22 UF +/-10%, 100V	436113	73445	C280MAH/A220K	2		
C12	CAP, MYLAR, 0.001 UF +/-10%, 100V	159582	56289	192P10292	1		
C13	CAP, MYLAR, 0.1 UF +/-10%, 100V	393439	73445	C280MAH/A100K	REF		
C14	CAP, MYLAR, 0.22 UF +/-10%, 100V	436113	73445	C280MAH/A220K	REF		
C15	CAP, TA, 0.22 UF +/-20%, 35V	161331	56289	196D224X0035HA1	5		
C16	CAP, TA, 0.22 UF +/-20%, 35V	161331	56289	196D224X0035HA1	REF		
C17	CAP, TA, 0.22 UF +/-20%, 35V	161331	56289	196D224X0035HA1	REF		
C18	CAP, TA, 0.22 UF +/-20%, 35V	161331	56289	196D224X0035HA1	REF		
C19	CAP, TA, 0.22 UF +/-20%, 35V	161331	56289	196D224X0035HA1	REF		
C20	CAP, MICA, 240 PF +/-5%, 500V	363863	72136	DM15F241J	1		
J10	SOCKET, IC, 16-PIN	387324	71785	133-59-02-062	2		
J21	SOCKET, IC, 16-PIN	387324	71785	133-59-02-062	REF		
P33	CABLE ASSY (5101A-4401)	463109	89536	463109	1		
Q10	XSTR, SI, PNP	226290	04713	MPS3690	2		
Q11	XSTR, SI, PNP	226290	04713	MPS3690	REF		
Q12	XSTR, SI, NPN	218396	04713	2N3904	1		
R1	RES, MTL. FILM, 750 +/-1%, 1/8W	312801	91637	MFF1-87500F	1		
R2	RES, VAR, 500 +/-20%, 1/2W	267849	11236	190PC501B	1		1
R3	RES, DEP. CAR, 20K +/-5%, 1/4W	441477	80031	CR251-4-5P20KT	1		
R8	RES, DEP. CAR, 150 +/-5%, 1/4W	343442	80031	CR251-4-5P500ET	3		
R9	RES, DEP. CAR, 22K +/-5%, 1/4W	348870	80031	CR251-4-5P22KT	3		
R11	RES, MTL. FILM, 4.32K +/-1%, 1/8W	294819	91637	MFF1-84321F	1		
R12	RES, DEP. CAR, 3K +/-5%, 1/4W	441527	80031	CR251-4-5P3KT	4		
R13	RES, VAR, 2K +/-20%, 1/2W	267864	11236	190PC202B	1		1
R14	RES, MTL. FILM, 10K +/-1%, 1/8W	168260	91637	MFF1-81001F	1		
R15	RES, DEP. CAR, 3K +/-5%, 1/4W	441527	80031	CR251-4-5P3KT	REF		
R16	RES, DEP. CAR, 3K +/-5%, 1/4W	441527	80031	CR251-4-5P3KT	REF		
R18	RES, DEP. CAR, 3K +/-5%, 1/4W	441527	80031	CR251-4-5P3KT	REF		
R19	RES, DEP. CAR, 150 +/-5%, 1/4W	343442	80031	CR251-4-5P500ET	REF		
R20	RES, DEP. CAR, 22K +/-5%, 1/4W	348870	80031	CR251-4-5P22KT	REF		
R21	RES, DEP. CAR, 150 +/-5%, 1/4W	343442	80031	CR251-4-5P500ET	REF		

Table 5-14. A8 Tape Interface PCB Assembly (cont)

REF DES	DESCRIPTION	FLUKE STOCK NO.	MFG SPLY CODE	MFG PART NO. OR TYPE	TOT QTY	REC QTY	NOTE
R22	RES, DEP. CAR, 22K +/-5%, 1/4W	348870	80031	CR251-4-5P22KT	REF		
R30	RES, DEP. CAR, 510 +/-5%, 1/4W	441600	80031	CR251-4-5P510E	1		
U1	IC, LINEAR TIMER	402610	18324	NE555N	1	1	
U2	IC, C-MOS, DUAL J-K, F/F	355230	12040	CD4027BCN	2	1	
U3	IC, C-MOS, QUAD, 2-INPUT NAND GATE	408401	02735	CD4081BE	2	1	
U4	⊗ IC, C-MOS, QUAD, 2-INPUT NOR GATES	355172	02735	CD4001AE	1	1	
U5	⊗ IC, C-MOS, 74C, DUAL "D" F/F	418830	12040	MM74C74	2	1	
U6	⊗ IC, C-MOS, 8-STAGE STATIC SHIFT RGSTR	380766	02735	CD4021AE	1	1	
U7	⊗ IC, C-MOS, QUAD, CLOCKED "D" LATCH	355149	02735	CD4042AE	2	1	
U8	⊗ IC, C-MOS, QUAD, CLOCKED "D" LATCH	355149	02735	CD4042AE	REF		
U9	⊗ IC, C-MOS, NAND GATES	375147	02735	CD4023AE	1	1	
U10	⊗ IC, C-MOS, QUAD, EXCLUSIVE OR GATES	355222	02735	CD4030AE	1	1	
U11	⊗ IC, C-MOS, PRESETTABLE UP/DOWN CNTR	452904	02735	CD4029AE	2	1	
U12	IC, TTL, LO-PWR, SCHOTTKY, MULTIVIBRATOR	404186	01295	SN74LS123N	1	1	
U13	IC, MONOSTABLE MULTIVIBRATOR	293050	01295	SN74121N	1	1	
U14	⊗ IC, C-MOS, PRESETTABLE UP/DOWN CNTR	452904	02735	CD4029AE	REF		
U15	⊗ IC, C-MOS, QUAD, 2-INPUT OR GATE	408393	02735	CD4071BE	1	1	
U16	⊗ IC, C-MOS, DUAL 4-INPUT POS NAND GATE	355206	04713	MC4012CP	1	1	
U18	⊗ IC, C-MOS, DUAL 4 BIT STATIC SHFT RGSTR	452896	02735	CD4015BE	1	1	
U19	⊗ IC, C-MOS, QUAD, CLOCKED "D" LATCH	412742	12040	MM74C173N	2	1	
U20	⊗ IC, C-MOS, QUAD, CLOCKED "D" LATCH	412742	12040	MM74C173N	REF		
U21	⊗ IC, C-MOS, TRI-STATE, HEX-NONINVT BFFRS	407759	12040	MM80C97N	2	1	
U22	⊗ IC, C-MOS, TRI-STATE, HEX-NONINVT BFFRS	407759	12040	MM80C97N	REF		
U23	⊗ IC, C-MOS, 74C, QUAD, "D" F/F	452912	12040	MM74C175N	1	1	
U24	⊗ IC, C-MOS, DUAL J-K, F/F	355230	12040	CD4027BCN	REF		
U25	⊗ IC, C-MOS, QUAD, 2-INPUT NAND GATE]	408401	02735	CD4081BE	REF		
U26	⊗ IC, C-MOS, 74C, DUAL "D" F/F	418830	12040	MM74C74	REF		
U27	⊗ IC, C-MOS, QUAD, 2-INPUT NAND GATE	355198	02735	CD4011AE	1	1	
XU13	SOCKET, IC, 14-PIN	276527	09922	DILB8P-108	1		

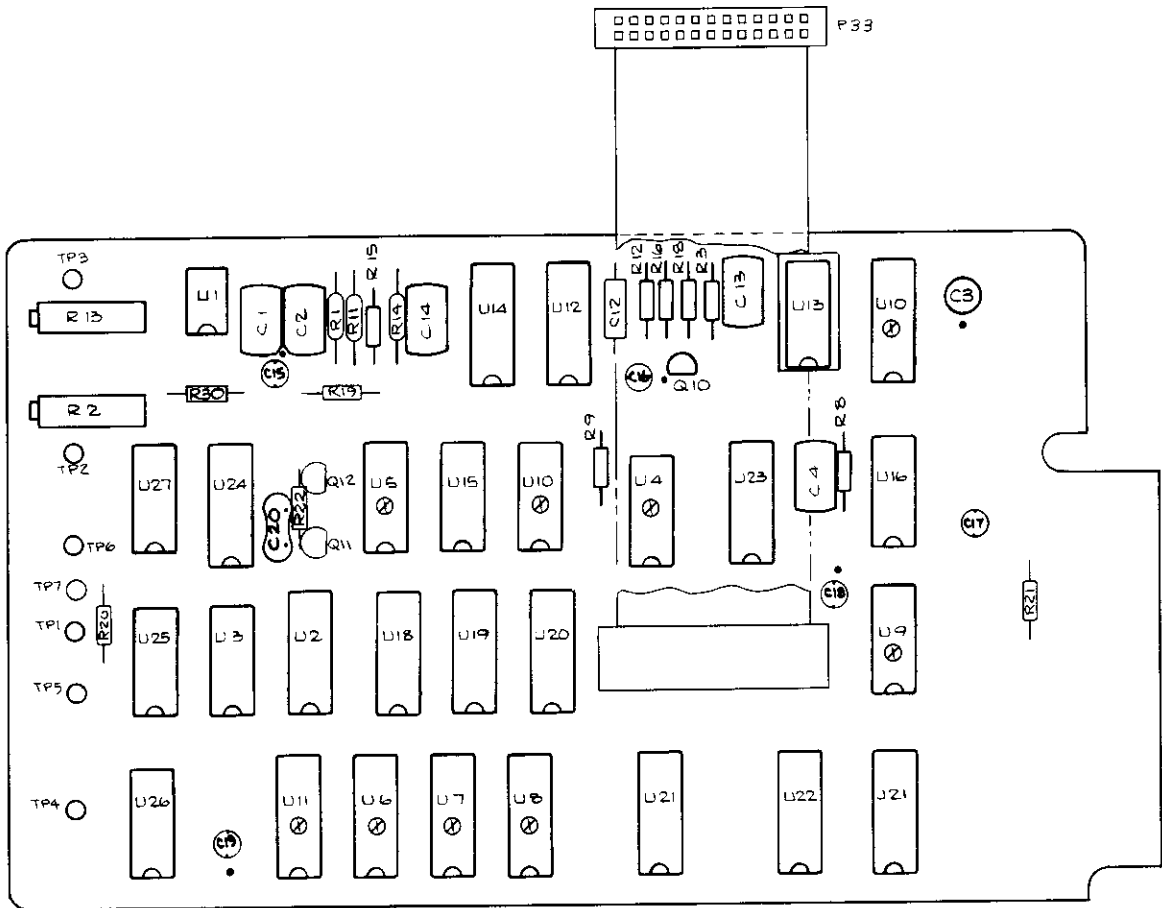

CAUTION
SUBJECT TO DAMAGE BY
STATIC ELECTRICITY

5101A-1730

Figure 5-9. A8 Tape Interface PCB Assembly

Table 5-15. A9 Power Supply Regulator PCB Assembly

REF DES	DESCRIPTION	FLUKE STOCK NO.	MFG SPLY CODE	MFG PART NO. OR TYPE	TOT QTY	REC QTY	N O T E
A9	⊗ PWR SUP REG PCB ASSEMBLY FIGURE 5-10 (5100A-4010T)	458398	89536	458398	REF		
C1	CAP, CER, 0.1 UF +/-20%, 100V	149146	56289	33C41B6	5		
C2	CAP, CER, 0.1 UF +/-20%, 100V	149146	56289	33C41B6	REF		
C3	CAP, MICA, 100 PF +/-5%, 500V	148494	72136	DM15F101J	3		
C4	CAP, CER, 0.1 UF +/-20%, 100V	149146	56289	33C41B6	REF		
C5	CAP, CER, 0.1 UF +/-20%, 100V	149146	56289	33C41B6	REF		
C6	CAP, CER, 0.1 UF +/-20%, 100V	149146	56289	33C41B6	REF		
C7	CAP, MICA, 100 PF +/-5%, 500V	148494	72136	DM15F101J	REF		
C8	CAP, CER, 2000 PF GMV, 1 KV	105569	71590	DA140-139CB	1		
C9	CAP, TA, 1 UF +/-20%, 25V	161919	56289	196D105X0035HA1	2		
C10	CAP, MICA, 30 PF +/-5%, 500V	340570	72136	DM15E300J	5		
C11	CAP, MICA, 3000 PF +/-5%, 500V	161786	72136	DM19F302J	5		
C12	CAP, TA, 22 UF +/-20%, 25V	357780	56289	196D226X0025PE4	2		
C13	CAP, TA, 22 UF +/-20%, 25V	357780	56289	196D226X0025PE4	REF		
C14	CAP, MICA, 30 PF +/-5%, 500V	340570	72136	DM15E300J	REF		
C15	CAP, MICA, 3000 PF +/-5%, 500V	161786	72136	DM19F302J	REF		
C16	CAP, MICA, 30 PF +/-5%, 500V	340570	72136	DM15E300J	REF		
C17	CAP, MICA, 3000 PF +/-5%, 500V	161786	72136	DM19F302J	REF		
C18	CAP, ELECT, 10 UF -10/+50%, 150V	106351	56289	30D105G150DD4	2		
C19	CAP, ELECT, 10 UF -10/+50%, 150V	106351	56289	30D105G150DD4	REF		
C20	CAP, MICA, 100 PF +/-5%, 500V	148494	72136	DM15F101J	REF		
C21	CAP, MICA, 30 PF +/-5%, 500V	340570	72136	DM15E300J	REF		
C22	CAP, MICA, 3000PF +/-5%, 500V	161786	72136	DM19F302J	REF		
C23	CAP, ELECT, 20 UF -10/+75%, 50V	106229	56289	30D206G050CC4	2	1	
C24	CAP, MICA, 30 PF +/-5%, 500V	340570	72136	DM15E300J	REF		
C25	CAP, MICA, 3000 PF +/-5%, 500V	161786	72136	DM19F302J	REF		
C26	CAP, ELECT, 20 UF -10/+75%, 50V	106229	56289	30D206G050CC4	REF		
C27	CAP, CER, 0.05 UF +/-20%, 100V	149161	56289	55C23A1	6		
C28	CAP, CER, 0.05 UF +/-20%, 100V	149161	56289	55C23A1	REF		
C29	CAP, CER, 0.22 UF +/-20%, 50V	309849	72982	8131-050-651M	9		
C30	CAP, CER, 0.22 UF +/-20%, 50V	309849	72982	8131-050-651M	REF		
C31	CAP, CER, 0.22 UF +/-20%, 50V	309849	72982	8131-050-651M	REF		
C32	CAP, CER, 0.22 UF +/-20%, 50V	309849	72982	8131-050-651M	REF		
C33	CAP, CER, 0.22 UF +/-20%, 50V	309849	72982	8131-050-651M	REF		
C34	CAP, CER, 0.22 UF +/-20%, 50V	309849	72982	8131-050-651M	REF		
C35	CAP, CER, 0.22 UF +/-20%, 50V	309849	72982	8131-050-651M	REF		
C36	CAP, CER, 0.22 UF +/-20%, 50V	309849	72982	8131-050-651M	REF		
C37	CAP, ELECT, 2 UF +50/-10%, 150V	267310	56289	30D205G150BB4	2	1	
C38	CAP, ELECT, 2 UF +50/-10%, 150V	267310	56289	30D205G150BB4	REF		
C39	CAP, CER, 0.22 UF +/-20%, 50V	309849	72982	8131-050-651M	REF		
C40	CAP, TA, 1 UF +/-20%, 25V	161919	56289	196D105X0035HA1	REF		
C41	CAP, TA, 150 UF +/-20%, 15V	422576	56289	196D157X0015TE4	1		
C42	CAP, TA, 5.6 UF +/-20%, 25V	368969	52689	196D566X0023KA1	1		
C60	CAP, TA, 68 UF +/-20%, 15V	193615	56289	196D686X0015TE4	2		
C61	CAP, PLSTC, 0.01 UF +/-10%, 50V	309906	06001	75F1R5A001	1		
C62	CAP, PLSTC, 0.47 UF +/-10%, 50V	271858	06001	75F1R5A474	1		
C63	CAP, TA, 68 UF +/-20%, 15V	193615	56289	196D686X0015TE4	REF		
C64	CAP, CER, 0.05 UF +/-20%, 100V	149161	56289	55C23A1	REF		

Table 5-15. A9 Power Supply Regulator PCB Assembly (cont)

REF DES	DESCRIPTION	FLUKE STOCK NO.	MFG SPLY CODE	MFG PART NO. OR TYPE	TOT QTY	REC QTY	N O T E
C65	CAP, CER, 0.05 UF +/-20%, 100V	149161	56289	55C23A1	REF		
C66	CAP, CER, 0.05 UF +/-20%, 100V	149161	56289	55C23A1	REF		
C67	CAP, CER, 0.05 UF +/-20%, 100V	149161	56289	55C23A1	REF		
CR2	DIODE, SI, RECTIFIER	368738	01295	1N4004	15	3	
CR3	DIODE, SI, RECTIFIER	368738	01295	1N4004	REF		
CR4	DIODE, SI, RECTIFIER	368738	01295	1N4004	REF		
CR5	DIODE, SI, RECTIFIER	368738	01295	1N4004	REF		
CR6	DIODE, SI, RECTIFIER	368738	01295	1N4004	REF		
CR7	DIODE, SI, RECTIFIER	368738	01295	1N4004	REF		
CR8	DIODE, SI, RECTIFIER	368738	01295	1N4004	REF		
CR9	DIODE, SI, RECTIFIER	368738	01295	1N4004	REF		
CR10	DIODE, SI, RECTIFIER	368738	01295	1N4004	REF		
CR11	DIODE, SI, RECTIFIER	368738	01295	1N4004	REF		
CR12	DIODE, SI, RECTIFIER	368738	01295	1N4004	REF		
CR13	DIODE, SI, RECTIFIER	368738	01295	1N4004	REF		
CR14	DIODE, SI, RECTIFIER	368738	01295	1N4004	REF		
CR15	DIODE, SI, RECTIFIER	368738	01295	1N4004	REF		
CR16	DIODE, SI, HI-SPEED SWITCHING	203323	07910	1N4448	2	1	
CR17	DIODE, SI, HI-SPEED SWITCHING	203323	07910	1N4448	REF		
CR19	DIODE, SI, RECTIFIER	368738	01295	1N4004	REF		
F1	FUSE, AGC, 4 AMP	216846	71400	AGC4A250V	2	10	
F2	FUSE, AGC, 4 AMP	216846	71400	AGC4A250V	REF		
F3	FUSE, AGC, 1/8 AMP	485110	75915	AGC3-8	1		
H1	SCREW, PHP, SEMS, 6-32 X 3/8	177022	89536	177022	16		
H2	SCREW, SEMS, 6-32 X 1/4	178533	89536	178533	1		
H3	SCREW, SEMS, 4-40 X 1/4	185918	89536	185918	2		
H4	NUT, HEX	147611	89536	147611	2		
MP1	CONNECTOR, RECEPTACLE, PCB	284281	00779	380598-2	8		
Q1	XSTR, SI, NPN	183012	86684	40251	2	1	
Q2	XSTR, SI, NPN	325720	04713	MJE3055	2	1	
Q3	XSTR, SI, PNP	325738	04713	MJE2955	2	1	
Q4	XSTR, SI, PNP	195974	04713	2N3906	3	1	
Q5	XSTR, SI, NPN	313213	86684	2N5240	2	1	
Q6	XSTR, SI, NPN	335067	04713	2N3439	1	1	
Q7	XSTR, SI, NPN	218396	04713	2N3904	3	1	
Q8	XSTR, SI, PNP	266619	07263	PN4888	2	1	
Q9	XSTR, SI, NPN	370684	12040	MPSA42	2	1	
Q10	XSTR, SI, PNP	195974	04713	2N3906	REF		
Q11	XSTR, SI, PNP	276899	86684	2N5415	1	1	
Q12	XSTR, SI, NPN	313213	86684	2N5240	REF		
Q13	XSTR, SI, PNP	325738	04713	MJE2955	REF		
Q14	XSTR, SI, NPN	325720	04713	MJE3055	REF		
Q15	XSTR, SI, NPN	183012	86684	40251	REF		
Q16	XSTR, SI, NPN	370684	12040	MPSA42	REF		
Q17	XSTR, SI, PNP	266619	07263	PN4888	REF		
Q18	XSTR, SI, NPN	218396	04713	2N3904	REF		
Q19	THYRISTOR, PLASTIC TRIAC	271668	89536	271668	2	1	
Q20	THYRISTOR, PLASTIC TRIAC	271668	89536	271668	REF		
Q21	XSTR, SI, NPN	218396	04713	2N3904	REF		
Q22	XSTR, SI, NPN	325761	06001	D44C5	2	1	

Table 5-15. A9 Power Supply Regulator PCB Assembly (cont)

REF DES	DESCRIPTION	FLUKE STOCK NO.	MFG SPLY CODE	MFG PART NO. OR TYPE	TOT QTY	REC QTY	N O T E
Q23	XSTR, SI, NPN	325761	06001	D44C5	REF		
Q24	XSTR, SI, PNP	195974	04713	2N3906	REF		
R1	RES, MTL. FILM, 1.43K +/-1%, 1/8W	325662	91637	CMF551431F	2		
R2	RES, MTL. FILM, 4.75K +/-1%, 1/8W	260679	91637	CMF554751F	2		
R3	RES, WW, 0.27 +/-5%, 2W	219428	75042	BWHR27J	3		1
R4	RES, COMP, 1 +/-5%, 1/2W	218693	01121	EB10G5	2		
R5	RES, MTL. FILM, 5.11K +/-1%, 1/8W	294868	91637	CMF555111F	1		
R6	RES, VAR, CER, 1K +/-10%, 1/2W	285155	89536	285155	3		
R7	RES, DEP. CAR, 51K +/-5%, 1/4W	376434	80031	CR251-4-5P51KTS	1		
R8	RES, MTL. FILM, 2.32K +/-1%, 1/8W	260315	91637	CMF552321F	1		
R9	RES, MTL. FILM, 7.5K +/-1%, 1/2W	192161	91637	CMF657501F	2		
R10	RES, MTL. FILM, 7.5K +/-1%, 1/2W	192161	91637	CMF657501F	REF		
R11	RES, DEP. CAR, 100 +/-5%, 1/4W	348771	80031	CR251-4-4P100ET	1		
R12	RES, COMP, 1 +/-5%, 1/2W	218693	01121	EB10G5	REF		
R14	RES, MTL. FILM, 110K +/-1%, 1/8W	234708	91637	CMF551103F	3		
R15	RES, COMP, 1.1 +/-5%, 1/2W	163717	01121	EB11G5	2		
R16	RES, MTL. FILM, 2K +/-1%, 1/8W	235226	91637	CMF552001F	3		
R17	RES, DEP. CAR, 13K +/-5%, 1/4W	441402	80031	CR251-4-5P13KT	2		
R19	RES, MTL. FILM, 107K +/-10%, 1/8W	288399	91637	CMF551073F	2		
R20	RES, MTL. FILM, 17.4K +/-1%, 1/8W	236802	91637	CMF551742F	2		
R21	RES, MTL. FILM, 5.62K +/-1%, 1/8W	235168	91637	CMF555621F	2		
R22	RES, MTL. FILM, 5.62K +/-1%, 1/8W	235168	91637	CMF555621F	REF		
R23	RES, MTL. FILM, 17.4K +/-1%, 1/8W	236802	91637	CMF551742F	REF		
R24	RES, MTL. FILM, 107K +/-10%, 1/8W	288399	91637	CMF551073F	REF		
R25	RES, COMP, 1.1 +/-5%, 1/2W	163717	01121	EB11G5	REF		
R28	RES, COMP, 3.9K +/-10%, 2W	110213	01121	HB3921	2		
R29	RES, MTL. FILM, 1.43K +/-1%, 1/8W	325662	91637	CMF551431F	REF		
R30	RES, MTL. FILM, 4.75K +/-1%, 1/8W	260679	91637	CMF554751F	REF		
R31	RES, WW, 0.27 +/-5%, 2W	219428	75042	BWHR27J	REF		
R32	RES, COMP, 4.7 +/-5%, 1/2W	188870	01121	EB47G5	2		
R33	RES, DEP. CAR, 3K +/-5%, 1/4W	441527	80031	CR251-4-5P3KT	3		
R34	RES, MTL. FILM, 110K +/-1%, 1/8W	234708	91637	CMF551103F	REF		
R35	RES, MTL. FILM, 15K +/-1%, 1/8W	285296	91637	CMF551502F	2		
R36	RES, MTL. FILM, 9.09K +/-1%, 1/8W	221663	91637	CMF559091F	2		
R37	RES, MTL. FILM, 15K +/-1%, 1/8W	285296	91637	CMF551502F	REF		
R38	RES, MTL. FILM, 9.09K +/-1%, 1/8W	221663	91637	CMF559091F	REF		
R39	RES, MTL. FILM, 110K +/-1%, 1/8W	234708	91637	CMF551103F	REF		
R40	RES, COMP, 4.7 +/-5%, 1/2W	188870	01121	EB47G5	REF		
R41	RES, DEP. CAR, 3K +/-5%, 1/4W	441527	80031	CR251-4-5P3KT	REF		
R42	RES, COMP, 3.9K +/-10%, 2W	110213	01121	HB3921	REF		
R43	RES, MTL. FILM, 2K +/-1%, 1/8W	235226	91637	CMF552001F	REF		
R44	RES, DEP. CAR, 100K +/-5%, 1/4W	348920	80031	CR251-4-5P100KT	3		
R45	RES, DEP. CAR, 100K +/-5%, 1/4W	348920	80031	CR251-4-5P100KT	REF		
R46	RES, DEP. CAR, 100K +/-5%, 1/4W	348920	80031	CR251-4-5P100KT	REF		
R47	RES, DEP. CAR, 3K +/-5%, 1/4W	441527	80031	CR251-4-5P3KT	REF		
R48	RES, DEP. CAR, 300 +/-5%, 1/4W	441519	80031	CR25-1-4-5P300ET	1		
R49	RES, DEP. CAR, 1K +/-5%, 1/4W	343426	80031	CR251-4-5P1KT	12		
R50	RES, DEP. CAR, 13K +/-5%, 1/4W	441402	80031	CR251-4-5P13KT	REF		
R53	RES, DEP. CAR, 1K +/-5%, 1/4W	343426	80031	CR251-4-5P1KT	REF		
R57	RES, MTL. FILM, 4.22 +/-1%, 1/8W	168245	91637	CMF554221F	1		

Table 3.5. A9 Power Supply Regulator PCB Assembly (cont)

REF DES	DESCRIPTION	FLUKE STOCK NO.	MFG SPLY CODE	MFG PART NO. OR TYPE	TOT QTY	REC QTY	NOTE
R60	RES, DEP. CAR, 1K +/-5%, 1/4W	343426	80031	CR251-4-5P1KT	REF		
R61	RES, DEP. CAR, 1K +/-5%, 1/4W	343426	80031	CR251-4-5P1KT	REF		
R62	RES, DEP. CAR, 1K +/-5%, 1/4W	343426	80031	CR251-4-5P1KT	REF		
R63	RES, DEP. CAR, 1K +/-5%, 1/4W	343426	80031	CR251-4-5P1KT	REF		
R64	RES, DEP. CAR, 1K +/-5%, 1/4W	343426	80031	CR251-4-5P1KT	REF		
R65	RES, DEP. CAR, 1K +/-5%, 1/4W	343426	80031	CR251-4-5P1KT	REF		
R66	RES, DEP. CAR, 1K +/-5%, 1/4W	343426	80031	CR251-4-5P1KT	REF		
R67	RES, DEP. CAR, 5.1K +/-5%, 1/4W	368712	80031	CR251-4-5P5K1T	2		
R68	RES, DEP. CAR, 5.1K +/-5%, 1/4W	368712	80031	CR251-4-5P5K1T	REF		
R69	RES, DEP. CAR, 2.2K +/-5%, 1/4W	343400	80031	CR251-4-5P2.2KT	2		
R70	RES, DEP. CAR, 2.2K +/-5%, 1/4W	343400	80031	CR251-4-5P2.2KT	REF		
R72	RES, DEP. CAR, 1K +/-5%, 1/4W	343426	80031	CR251-4-5P1KT	REF		
R73	RES, DEP. CAR, 6.8K +/-5%, 1/4W	368761	80031	CR251-4-5P6-8KT	1		
R74	RES, MTL. FILM, 100 +/-1%, 1/8W	168195	91637	CMF551000F	1		
R75	RES, MTL. FILM, 1.5K +/-1%, 1/8W	313098	91637	CMF551501F	2		
R76	RES, MTL. FILM, 1.5K +/-1%, 1/8W	313098	91637	CMF551501F	REF		
R77	RES, WW, 0.27 +/-5%, 2W	219428	75042	BWHR27J	REF		
R78	RES, DEP. CAR, 1K +/-5%, 1/4W	343426	80031	CR251-4-5P1KT	REF		
R79	RES, WW, 0.47 +/-5%, 2W	219360	75042	BWHR47J	1		
R80	RES, MTL. FILM, 25.5K +/-1%, 1/8W	221630	91637	CMF552552F	1		
R81	RES, MTL. FILM, 2K +/-1%, 1/8W	235226	91637	CMF552001F	REF		
R82	RES, DEP. CAR, 1K +/-5%, 1/4W	343426	80031	CR251-4-5P1KT	REF		
R83	RES, VAR, CER, 1K +/-10%, 1/2W	285155	89536	285155	REF		
R84	RES, VAR, CER, 1K +/-10%, 1/2W	285155	89536	285155	REF		
R85	RES, COMP, 5.1 +/-5%, 1/2W	177147	01121	EB51G5	2		
R86	RES, COMP, 5.1 +/-5%, 1/2W	177147	01121	EB51G5	REF		
U1	IC, LIN, VOLTAGE REGULATOR	413195	04713	MC7812CP	1	1	
U2	IC, LIN, NEGATIVE VOLTAGE REGULATOR	381665	04713	MC7912CP	1	1	
U3	IC, LIN, VOLTAGE REGULATOR	379420	04713	MC1723CL	3	1	
U4	IC, LIN, VOLTAGE REGULATOR	355107	07263	F7805UC	1	1	
U5	IC, LIN, VOLTAGE REGULATOR	413187	04713	MC815CP	1	1	
U6	IC, LIN, NEGATIVE VOLTAGE REGULAOR	413179	04713	MC7915CP	1	1	
U7	IC, LIN, VOLTAGE REGULATOR	379420	04713	MC1723CL	REF		
U8	IC, OP AMP	363515	24355	AD301AN	5	1	
U9	IC, OP AMP	363515	24355	AD301AN	REF		
U10	IC, OP AMP	363515	24355	AD301AN	REF		
U11	IC, LIN, VOLTAGE REGULATOR	379420	04713	MC1723CL	REF		
U12	IC, OP AMP	363515	24355	AD301AN	REF		
U13	IC, OP AMP	363515	24355	AD301AN	REF		
U14	⊗ IC, C-MOS, DUAL, RETRIG, RESET	393512	02735	CD4098AE	1	1	
U15	⊗ IC, C-MOS, HEX, INVERTER/BUFFER	381848	02735	CD4049AE	1	1	
U16	IC, LINEAR, TIMER	402610	12040	LM555CN	1	1	
VR1	DIODE, ZENER, UNCOMP.	277236	07910	1N752A	2		
VR2	DIODE, ZENER, UNCOMP.	325837	07910	1N966B	1		
VR3	DIODE, ZENER, 4.3V	180455	01295	1N749A	2		
VR4	DIODE, ZENER, UNCOMP.	418665	07910	1N978B	REF		
VR5	DIODE, ZENER, UNCOMP.	453134	12969	UZ8730	2		
VR6	DIODE, ZENER, UNCOMP.	453134	12969	UZ8730	REF		
VR7	DIODE, ZENER, 4.3V	180455	01295	1N749A	REF		
VR8	DIODE, ZENER, UNCOMP.	418665	07910	1N978B	REF		

Table 5-15. A9 Power Supply Regulator PCB Assembly (cont)

REF DES	DESCRIPTION	FLUKE STOCK NO.	MFG SPLY CODE	MFG PART NO. OR TYPE	TOT QTY	REC QTY	N O T E
VR9	DIODE, ZENER, UNCOMP.	267807	07910	1N970B	2		
VR10	DIODE, ZENER, UNCOMP.	267807	07910	1N970B	REF		
VR11	DIODE, ZENER, UNCOMP.	277236	07910	1N752A	REF		
VR12	DIODE, ZENER	454595	12969	UZ8706	4		
VR13	DIODE, ZENER	454595	12969	UZ8706	REF		
VR14	DIODE, ZENER	454595	12969	UZ8706	REF		
VR15	DIODE, ZENER	454595	12969	UZ8706	REF		
XF1	FUSEHOLDER, CLIP TYPE	284984	84613	3621-2	4		
XF2	FUSEHOLDER, CLIP TYPE	284984	84613	3621-2	REF		
XF3	FUSEHOLDER, CLIP TYPE	284984	84613	3621-2	REF		
XQ1	HEATSINK	342675	13103	6003-B-2	4		
XQ2	HEATSINK	453878	89536	453878	4		
XQ3	HEATSINK	453878	89536	453878	REF		
XQ5	HEATSINK	342675	13103	6003-B-2	REF		
XQ6	TRANSIPAD	152207	07047	10123DAP	2		
XQ11	TRANSIPAD	152207	07047	10123DAP	REF		
XQ12	HEATSINK	342675	13103	6003-B-2	REF		
XQ13	HEATSINK	352765	13103	6107-B14	4		
XQ14	HEATSINK	352765	13103	6107-B14	REF		
XQ15	HEATSINK	342675	13103	6003-B-2	REF		
XU1	HEATSINK	453878	89536	453878	REF		
XU2	HEATSINK	453878	89536	453878	REF		
XU5	HEATSINK	352765	13103	6107-B14	REF		
XU6	HEATSINK	352765	13103	6107-B14	REF		

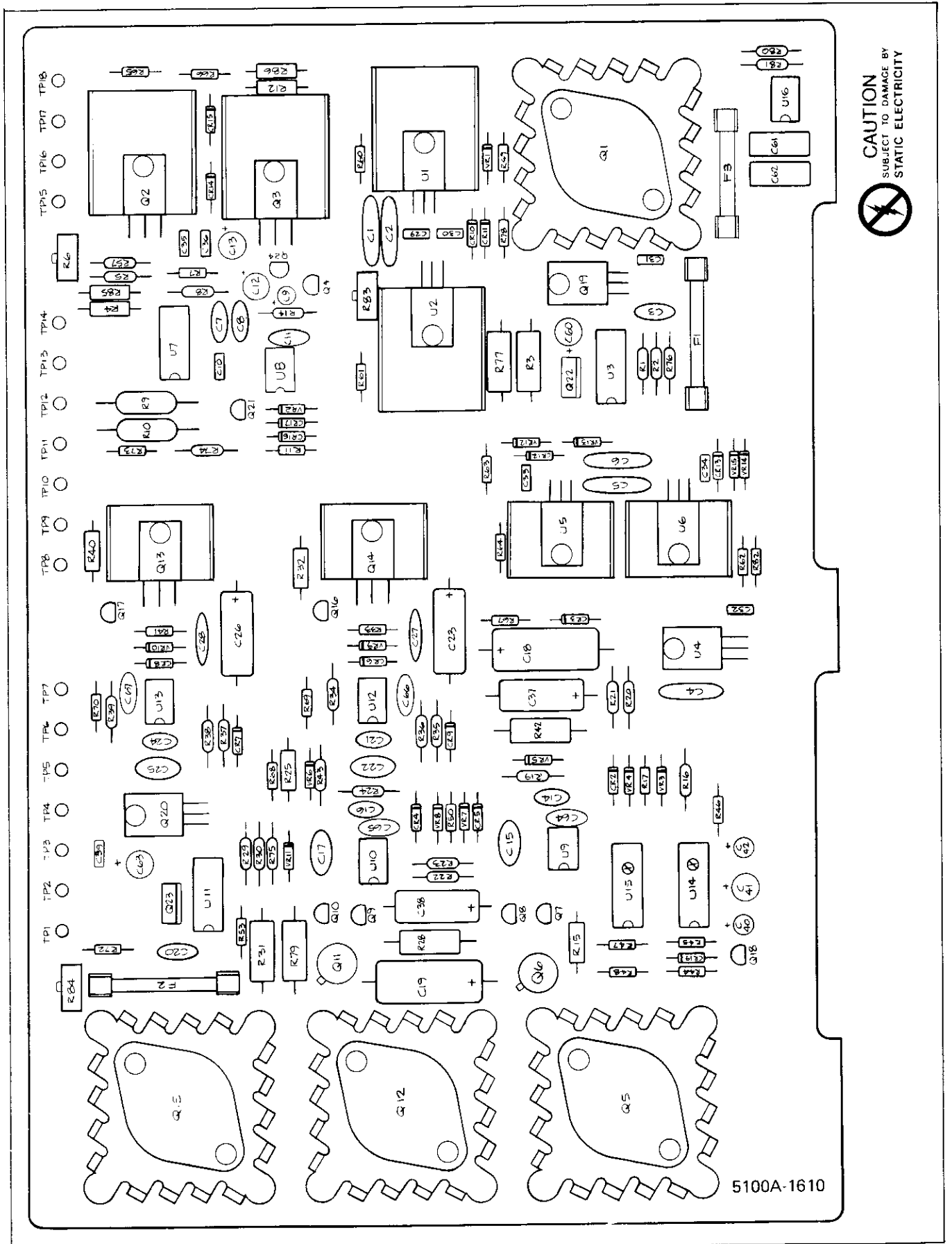

CAUTION
SUBJECT TO DAMAGE BY
STATIC ELECTRICITY

5100A-1610

Figure 5-10. A9 Power Supply Regulator PCB Assembly

Table 5-16. A10 Front Panel PCB Assembly, Non-Storage

REF DES	DESCRIPTION	FLUKE STOCK NO.	MFG SPLY CODE	MFG PART NO. OR TYPE	TOT QTY	REC QTY	NOTE
A10	⊗ FRONT PANEL PCB ASSEMBLY FIGURE 5-11 (5100A-4020T)	458406	89536	458406	REF		
A10A1	DISPLAY PCB ASSEMBLY FIGURE 5-13 (5100A-4021)	456004	89536	456004	1		
C1	CAP, TA, 1 UF +/-20%, 35V	161919	56289	1960105X0035JA1	2		
C2	CAP, CER, 0.047 UF +/-20%, 40V	460733	71590	CW20C473M	8		
C3	CAP, CER, 0.047 UF +/-20%, 40V	460733	71590	CW20C473M	REF		
C4	CAP, CER, 0.047 UF +/-20%, 40V	460733	71590	CW20C473M	REF		
C5	CAP, CER, 0.047 UF +/-20%, 40V	460733	71590	CW20C473M	REF		
C6	CAP, CER, 0.047 UF +/-20%, 40V	460733	71590	CW20C473M	REF		
C7	CAP, TA, 1 UF +/-20%, 35V	161919	56289	1960105X0035JA1	REF		
C8	CAP, CER, 0.047 UF +/-20%, 40V	460733	71590	CW20C473M	REF		
C9	CAP, CER, 0.047 UF +/-20%, 40V	460733	71590	CW20C473M	REF		
C10	CAP, CER, 0.047 UF +/-20%, 40V	460733	71590	CW20C473M	REF		
C11	CAP, TA, 6.8 UF +/-20%, 35V	363713	56289	1960685X0035KA1	2		
C12	CAP, TA, 6.8 UF +/-20%, 35V	363713	56289	1960685X0035KA1	REF		
CR3	DIODE, LIGHT EMITTING	369777	28480	5082-4480	13	3	
CR4	DIODE, LIGHT EMITTING	369777	28480	5082-4480	REF		
CR5	DIODE, LIGHT EMITTING	369777	28480	5082-4480	REF		
CR6	DIODE, LIGHT EMITTING	369777	28480	5082-4480	REF		
CR7	DIODE, LIGHT EMITTING	369777	28480	5082-4480	REF		
CR8	DIODE, LIGHT EMITTING	369777	28480	5082-4480	REF		
CR9	DIODE, LIGHT EMITTING	369777	28480	5082-4480	REF		
CR10	DIODE, LIGHT EMITTING	369777	28480	5082-4480	REF		
CR11	DIODE, LIGHT EMITTING	369777	28480	5082-4480	REF		
CR12	DIODE, LIGHT EMITTING	369777	28480	5082-4480	REF		
CR13	DIODE, LIGHT EMITTING	369777	28480	5082-4480	REF		
CR14	DIODE, LIGHT EMITTING	369777	28480	5082-4480	REF		
CR15	DIODE, LIGHT EMITTING	369777	28480	5082-4480	REF		
CR44	DIODE, SI	343491	04713	IN4002	1	1	
CR45	DIODE, SI	347559	14099	IN5400	1		
H1	WASHER, LOCK INT	129957	78189	1220-05	1		
H2	WASHER, FLAT	110007	89536	110007	1		
H3	NUT, HEX, 32-3/8	129718	73734	9002-NP	1		
H4	NUT, HEX, 4-40	110635	89536	110635	8		
H5	SPACER, STANDOFF, 4-40	335604	89536	335604	7		
H6	SCREW, PHP, 4-40 X 1/4	129890	89536	129890	6		
H7	SCREW, PH, SEMS, 4-40 X 1/4	185918	89536	185918	8		
MP1	SPACER, STANDOFF, 6-32	296137	89536	296137	1		
P10	CABLE ASSEMBLY, FLAT	428409	89536	428409	2		
P21	CABLE ASSEMBLY, FLAT	428409	89536	428409	REF		
Q1	XSTR, PWR NPN	386128	01295	T1P120	8	2	
Q2	XSTR, PWR NPN	386128	01295	T1P120	REF		
Q3	XSTR, PWR NPN	386128	01295	T1P120	REF		
Q4	XSTR, PWR NPN	386128	01295	T1P120	REF		
Q5	XSTR, PWR NPN	386128	01295	T1P120	REF		
Q6	XSTR, PWR NPN	386128	01295	T1P120	REF		
Q7	XSTR, PWR NPN	386128	01295	T1P120	REF		
Q8	XSTR, PWR NPN	386128	01295	T1P120	REF		

Table B 10. A10 Front Panel PCB Assembly, Non-Storage (cont)

REF DES	DESCRIPTION	FLUKE STOCK NO.	MFG PLY CODE	MFG PART NO. OR TYPE	TOT QTY	REC QTY	N O T E
Q9	XSTR, SI, PNP	226290	04713	MPS3640	1	1	
R1	RES, DEP. CAR, 22K +/-5%, 1/4W	348870	80031	CR251-45P22KT	1		
R2	RES, DEP. CAR, 150 +/-5%, 1/4W	343442	80031	CR251-45P150ET	1		
R3	RES, DEP. CAR, 1K +/-5%, 1/4W	343426	80031	CR251-4P51KT	1		
R4	RES, DEP. CAR, 10K +/-5%, 1/4W	348839	80031	CR251-45P10KT	4		
R5	RES, DEP. CAR, 10K +/-5%, 1/4W	348839	80031	CR251-45P10KT	REF		
R6	RES, DEP. CAR, 10K +/-5%, 1/4W	348839	80031	CR251-45P10KT	REF		
R7	RES, DEP. CAR, 10K +/-5%, 1/4W	348839	80031	CR251-45P10KT	REF		
R8	RES, DEP. CAR, 47K +/-5%, 1/4W	348896	80031	CR251-45P47KT	1		
R9	RES, DEP. CAR, 33 +/-5%, 1/4W	414524	80031	CR251-45P33ET	4		
R10	RES, DEP. CAR, 33 +/-5%, 1/4W	414524	80031	CR251-45P33ET	REF		
R11	RES, DEP. CAR, 33 +/-5%, 1/4W	414524	80031	CR251-45P33ET	REF		
R12	RES, DEP. CAR, 33 +/-5%, 1/4W	414524	80031	CR251-45P33ET	REF		
RN1	RES, NETWORK, 2K	446880	89536	446880	1	1	
RN2	RES, NETWORK, 10K	414003	89536	414003	1	1	
RN3	RES, NETWORK, 39 +/-5%, 1/4W	519348	89536	519348	2	1	
RN4	RES, NETWORK, 39 +/-5%, 1/4W	519348	89536	519348	REF		
S1	PUSHBUTTON, LIGHT GREY	401307	89536	401307	21		
S1-1	COVER, SW	401299	89536	401299	42		
S1-2	SPRING, SW, PB	414516	00779	62353-3	50		
S1-3	CONTACT, SW, PB	416875	00779	62380-4	50		
S1-4	ACTUATOR, SW	412106	89536	412106	42		
S2	PUSHBUTTON, LIGHT GREY	401307	89536	401307	REF		
S2-1	COVER, SW	401299	89536	401299	REF		
S2-2	SPRING, SW, PB	414516	00779	62353-3	REF		
S2-3	CONTACT, SW, PB	416875	00779	62380-4	REF		
S2-4	ACTUATOR, SW	412106	89536	412106	REF		
S3	PUSHBUTTON, DK GREY	406868	89536	406868	2		
S3-1	COVER, SW	401299	89536	401299	REF		
S3-2	SPRING, SW, PB	414516	00779	62353-3	REF		
S3-3	CONTACT, SW, PB	416875	00779	62380-4	REF		
S3-4	ACTUATOR, SW	412106	89536	412106	REF		
S4	PUSHBUTTON, DK GREY	406868	89536	406868	REF		
S4-1	COVER, SW	401299	89536	401299	REF		
S4-2	SPRING, SW, PB	414516	00779	62353-3	REF		
S4-3	CONTACT, SW, PB	416875	00779	62380-4	REF		
S4-4	ACTUATOR, SW	412106	89536	412106	REF		
S5	PUSHBUTTON, LIGHT GREY	401307	89536	401307	REF		
S5-1	COVER, SW	401299	89536	401299	REF		
S5-2	SPRING, SW, PB	414516	00779	62353-3	REF		
S5-3	CONTACT, SW, PB	416875	00779	62380-4	REF		
S5-4	ACTUATOR, SW	412106	89536	412106	REF		
S6	PUSHBUTTON, LIGHT GREY	401307	89536	401307	REF		
S6-1	COVER, SW	401299	89536	401299	REF		
S6-2	SPRING, SW, PB	414516	00779	62353-3	REF		
S6-3	CONTACT, SW, PB	416875	00779	62380-4	REF		
S6-4	ACTUATOR, SW	412106	89536	412106	REF		
S7	PUSHBUTTON, LIGHT GREY	401307	89536	401307	REF		
S7-1	COVER, SW	401299	89536	401299	REF		
S7-2	SPRING, SW, PB	414516	00779	62353-3	REF		

Table 5-16. A10 Front Panel PCB Assembly, Non-Storage (cont)

REF DES	DESCRIPTION	FLUKE STOCK NO.	MFG SPLY CODE	MFG PART NO. OR TYPE	TOT QTY	REC QTY	NOTE
S7-3	CONTACT, SW, PB	416875	00779	62380-4	REF		
S7-4	ACTUATOR, SW	412106	89536	412106	REF		
S8	PUSHBUTTON, LIGHT GREY	401307	89536	401307	REF		
S8-1	COVER, SW	401299	89536	401299	REF		
S8-2	SPRING, SW, PB	414516	00779	62353-3	REF		
S8-3	CONTACT, SW, PB	416875	00779	62380-4	REF		
S8-4	ACTUATOR, SW	412106	89536	412106	REF		
S9	PUSHBUTTON, LIGHT GREY	401307	89536	401307	REF		
S9-1	COVER, SW	401299	89536	401299	REF		
S9-2	SPRING, SW, PB	414516	00779	62353-3	REF		
S9-3	CONTACT, SW, PB	416875	00779	62380-4	REF		
S9-4	ACTUATOR, SW	412106	89536	412106	REF		
S10	PUSHBUTTON, LIGHT GREY	401307	89536	401307	REF		
S10-1	COVER, SW	401299	89536	401299	REF		
S10-2	SPRING, SW, PB	414516	00779	62353-3	REF		
S10-3	CONTACT, SW, PB	416875	00779	62380-4	REF		
S10-4	ACTUATOR, SW	412106	89536	412106	REF		
S11	PUSHBUTTON, LIGHT GREY	401307	89536	401307	REF		
S11-1	COVER, SW	401299	89536	401299	REF		
S11-2	SPRING, SW, PB	414516	00779	62353-3	REF		
S11-3	CONTACT, SW, PB	416875	00779	62380-4	REF		
S11-4	ACTUATOR, SW	412106	89536	412106	REF		
S12	PUSHBUTTON, LIGHT GREY	401307	89536	401307	REF		
S12-1	COVER, SW	401299	89536	401299	REF		
S12-2	SPRING, SW, PB	414516	00779	62353-3	REF		
S12-3	CONTACT, SW, PB	416875	00779	62380-4	REF		
S12-4	ACTUATOR, SW	412106	89536	412106	REF		
S13	PUSHBUTTON, WHITE	406744	89536	406744	12		
S13-1	COVER, SW	401299	89536	401299	REF		
S13-2	SPRING, SW, PB	414516	00779	62353-3	REF		
S13-3	CONTACT, SW, PB	416875	00779	62380-4	REF		
S13-4	ACTUATOR, SW	412106	89536	412106	REF		
S14	PUSHBUTTON, WHITE	406744	89536	406744	REF		
S14-1	COVER, SW	401299	89536	401299	REF		
S14-2	SPRING, SW, PB	414516	00779	62353-3	REF		
S14-3	CONTACT, SW, PB	416875	00779	62380-4	REF		
S14-4	ACTUATOR, SW	412106	89536	412106	REF		
S15	PUSHBUTTON, WHITE	406744	89536	406744	REF		
S15-1	COVER, SW	401299	89536	401299	REF		
S15-2	SPRING, SW, PB	414516	00779	62353-3	REF		
S15-3	CONTACT, SW, PB	416875	00779	62380-4	REF		
S15-4	ACTUATOR, SW	412106	89536	412106	REF		
S16	PUSHBUTTON, WHITE	406744	89536	406744	REF		
S16-1	COVER, SW	401299	89536	401299	REF		
S16-2	SPRING, SW, PB	414516	00779	62353-3	REF		
S16-3	CONTACT, SW, PB	416875	00779	62380-4	REF		
S16-4	ACTUATOR, SW	412106	89536	412106	REF		
S17	PUSHBUTTON, WHITE	406744	89536	406744	REF		
S17-1	COVER, SW	401299	89536	401299	REF		
S17-2	SPRING, SW, PB	414516	00779	62353-3	REF		

Table 5-16. A10 Front Panel PCB Assembly, Non-Storage (cont)

REF DES	DESCRIPTION	FLUKE STOCK NO.	MFG SPLY CODE	MFG PART NO. OR TYPE	TOT QTY	REC QTY	NOTE
S17-3	CONTACT, SW, PB	416875	00779	62380-4	REF		
S17-4	ACTUATOR, SW	412106	89536	412106	REF		
S18	PUSHBUTTON, WHITE	406744	89536	406744	REF		
S18-1	COVER, SW	401299	89536	401299	REF		
S18-2	SPRING, SW, PB	414516	00779	62353-3	REF		
S18-3	CONTACT, SW, PB	416875	00779	62380-4	REF		
S18-4	ACTUATOR, SW	412106	89536	412106	REF		
S19	PUSHBUTTON, WHITE	406744	89536	406744	REF		
S19-1	COVER, SW	401299	89536	401299	REF		
S19-2	SPRING, SW, PB	414516	00779	62353-3	REF		
S19-3	CONTACT, SW, PB	416875	00779	62380-4	REF		
S19-4	ACTUATOR, SW	412106	89536	412106	REF		
S20	PUSHBUTTON, WHITE	406744	89536	406744	REF		
S20-1	COVER, SW	401299	89536	401299	REF		
S20-2	SPRING, SW, PB	414516	00779	62353-3	REF		
S20-3	CONTACT, SW, PB	416875	00779	62380-4	REF		
S20-4	ACTUATOR, SW	412106	89536	412106	REF		
S21	PUSHBUTTON, WHITE	406744	89536	406744	REF		
S21-1	COVER, SW	401299	89536	401299	REF		
S21-2	SPRING, SW, PB	414516	00779	62353-3	REF		
S21-3	CONTACT, SW, PB	416875	00779	62380-4	REF		
S21-4	ACTUATOR, SW	412106	89536	412106	REF		
S22	PUSHBUTTON, WHITE	406744	89536	406744	REF		
S22-1	COVER, SW	401299	89536	401299	REF		
S22-2	SPRING, SW, PB	414516	00779	62353-3	REF		
S22-3	CONTACT, SW, PB	416875	00779	62380-4	REF		
S22-4	ACTUATOR, SW	412106	89536	412106	REF		
S23	PUSHBUTTON, WHITE	406744	89536	406744	REF		
S23-1	COVER, SW	401299	89536	401299	REF		
S23-2	SPRING, SW, PB	414516	00779	62353-3	REF		
S23-3	CONTACT, SW, PB	416875	00779	62380-4	REF		
S23-4	ACTUATOR, SW	412106	89536	412106	REF		
S24	PUSHBUTTON, WHITE	406744	89536	406744	REF		
S24-1	COVER, SW	401299	89536	401299	REF		
S24-2	SPRING, SW, PB	414516	00779	62353-3	REF		
S24-3	CONTACT, SW, PB	416875	00779	62380-4	REF		
S24-4	ACTUATOR, SW	412106	89536	412106	REF		
S25	PUSHBUTTON, SQ, BLUE	406736	89536	406736	1		
S25-1	COVER, SW	401299	89536	401299	REF		
S25-2	SPRING, SW, PB	414516	00779	62353-3	REF		
S25-3	CONTACT, SW, PB	416875	00779	62380-4	REF		
S25-4	ACTUATOR, SW	412106	89536	412106	REF		
S26	PUSHBUTTON, DK ORANGE	420620	89536	420620	1		
S26-1	COVER, SW	401299	89536	401299	REF		
S26-2	SPRING, SW, PB	414516	00779	62353-3	REF		
S26-3	CONTACT, SW, PB	416875	00779	62380-4	REF		
S26-4	ACTUATOR, SW	412106	89536	412106	REF		
S27	PUSHBUTTON, LIGHT GREY	401307	89536	401307	REF		
S27-1	COVER, SW	401299	89536	401299	REF		
S27-2	SPRING, SW, PB	414516	00779	62353-3	REF		

Table 5-16. A10 Front Panel PCB Assembly, Non-Storage (cont)

REF DES	DESCRIPTION	FLUKE STOCK NO.	MFG SPLY CODE	MFG PART NO. OR TYPE	TOT QTY	REC QTY	N O T E
S27-3	CONTACT, SW, PB	416875	00779	62380-4	REF		
S27-4	ACTUATOR, SW	412106	89536	412106	REF		
S28	PUSHBUTTON, LIGHT GREY	401307	89536	401307	REF		
S28-1	COVER, SW	401299	89536	401299	REF		
S28-2	COVER, SW	401299	89536	401299	REF		
S28-3	CONTACT, SW, PB	416875	00779	62380-4	REF		
S28-4	ACTUATOR, SW	412106	89536	412106	REF		
S29	PUSHBUTTON, LIGHT GREY	401307	89536	401307	REF		
S29-1	COVER, SW	401299	89536	401299	REF		
S29-2	SPRING, SW, PB	414516	00779	62353-3	REF		
S29-3	CONTACT, SW, PB	416875	00779	62380-4	REF		
S29-4	ACTUATOR, SW	412106	89536	412106	REF		
S30	PUSHBUTTON, LIGHT GREY	401307	89536	401307	REF		
S30-1	COVER, SW	401299	89536	401299	REF		
S30-2	SPRING, SW, PB	414516	00779	62353-3	REF		
S30-3	CONTACT, SW, PB	416875	00779	62380-4	REF		
S30-4	ACTUATOR, SW	412106	89536	412106	REF		
S31	PUSHBUTTON, LIGHT GREY	401307	89536	401307	REF		
S31-1	COVER, SW	401299	89536	401299	REF		
S31-2	SPRING, SW, PB	414516	00779	62353-3	REF		
S31-3	CONTACT, SW, PB	416875	00779	62380-4	REF		
S31-4	ACTUATOR, SW	412106	89536	412106	REF		
S32	PUSHBUTTON, LIGHT GREY	401307	89536	401307	REF		
S32-1	COVER, SW	401299	89536	401299	REF		
S32-2	SPRING, SW, PB	414516	00779	62353-3	REF		
S32-3	CONTACT, SW, PB	416875	00779	62380-4	REF		
S32-4	ACTUATOR, SW	412106	89536	412106	REF		
S33	PUSHBUTTON, LIGHT GREY	401307	89536	401307	REF		
S33-1	COVER, SW	401299	89536	401299	REF		
S33-2	SPRING, SW, PB	414516	00779	62353-3	REF		
S33-3	CONTACT, SW, PB	416875	00779	62380-4	REF		
S33-4	ACTUATOR, SW	412106	89536	412106	REF		
S34	PUSHBUTTON, LIGHT GREY	401307	89536	401307	REF		
S34-1	COVER, SW	401299	89536	401299	REF		
S34-2	SPRING, SW, PB	414516	00779	62353-3	REF		
S34-3	CONTACT, SW, PB	416875	00779	62380-4	REF		
S34-4	ACTUATOR, SW	412106	89536	412106	REF		
S35	PUSHBUTTON, LIGHT GREY	401307	89536	401307	REF		
S35-1	COVER, SW	401299	89536	401299	REF		
S35-2	SPRING, SW, PB	414516	00779	62353-3	REF		
S35-3	CONTACT, SW, PB	416875	00779	62380-4	REF		
S35-4	ACTUATOR, SW	412106	89536	412106	REF		
S36	PUSHBUTTON, LIGHT GREY	401307	89536	401307	REF		
S36-1	COVER, SW	401299	89536	401299	REF		
S36-2	SPRING, SW, PB	414516	00779	62353-3	REF		
S36-3	CONTACT, SW, PB	416875	00779	62380-4	REF		
S36-4	ACTUATOR, SW	412106	89536	412106	REF		
S37	PUSHBUTTON, SQ, DK GREY	406728	89536	406728	REF	5	
S37-1	COVER, SW	401299	89536	401299	REF		
S37-2	SPRING, SW, PB	414516	00779	62353-3	REF		

Table 5-16. A10 Front Panel PCB Assembly, Non-Storage (cont)

REF DES	DESCRIPTION	FLUKE STOCK NO.	MFG SPLY CODE	MFG PART NO. OR TYPE	TOT QTY	REC QTY	N O T E
S37-3	CONTACT, SW, PB	416875	00779	62380-4	REF		
S37-4	ACTUATOR, SW	412106	89536	412106	REF		
S38	PUSHBUTTON, SQ, DK GREY	406728	89536	406728	REF		
S38-1	COVER, SW	401299	89536	401299	REF		
S38-2	SPRING, SW, PB	414516	00779	62353-3	REF		
S38-3	CONTACT, SW, PB	416875	00779	62380-4	REF		
S38-4	ACTUATOR, SW	412106	89536	412106	REF		
S39-2	SPRING, SW, PB	414516	00779	62353-3	REF		
S39-3	CONTACT, SW, PB	416875	00779	62380-4	REF		
S40-2	SPRING, SW, PB	414516	00779	62353-3	REF		
S40-3	CONTACT, SW, PB	416875	00779	62380-4	REF		
S41-2	SPRING, SW, PB	414516	00779	62353-3	REF		
S41-3	CONTACT, SW, PB	416875	00779	62380-4	REF		
S42-2	SPRING, SW, PB	414516	00779	62353-3	REF		
S42-3	CONTACT, SW, PB	416875	00779	62380-4	REF		
S43-2	SPRING, SW, PB	414516	00779	62353-3	REF		
S43-3	CONTACT, SW, PB	416875	00779	62380-4	REF		
S44-2	SPRING, SW, PB	414516	00779	62353-3	REF		
S44-3	CONTACT, SW, PB	416875	00779	62380-4	REF		
S45-2	SPRING, SW, PB	414516	00779	62353-3	REF		
S45-3	CONTACT, SW, PB	416875	00779	62380-4	REF		
S46-2	SPRING, SW, PB	414516	00779	62353-3	REF		
S46-3	CONTACT, SW, PB	416875	00779	62380-4	REF		
S47	PUSHBUTTON, LIGHT GREY	401307	89536	401307	REF		
S47-1	COVER, SW	401299	89536	401299	REF		
S47-2	SPRING, SW, PB	414516	00779	62353-3	REF		
S47-3	CONTACT, SW, PB	416875	00779	62380-4	REF		
S47-4	ACTUATOR, SW	412106	89536	412106	REF		
S48	PUSHBUTTON, SQ, DK GREY	406728	89536	406728	REF		
S48-1	COVER, SW	401299	89536	401299	REF		
S48-2	SPRING, SW, PB	414516	00779	62353-3	REF		
S48-3	CONTACT, SW, PB	416875	00779	62380-4	REF		
S48-4	ACTUATOR, SW	412106	89536	412106	REF		
S49	PUSHBUTTON, SQ, DK GREY	406728	89536	406728	REF		
S49-1	COVER, SW	401299	89536	401299	REF		
S49-2	SPRING, SW, PB	414516	00779	62353-3	REF		
S49-3	CONTACT, SW, PB	416875	00779	62380-4	REF		
S49-4	ACTUATOR, SW	412106	89536	412106	REF		
S50	PUSHBUTTON, SQ, DK GREY	406728	89536	406728	REF		
S50-1	COVER, SW	401299	89536	401299	REF		
S50-2	SPRING, SW, PB	414516	00779	62353-3	REF		
S50-3	CONTACT, SW, PB	416875	00779	62380-4	REF		
S50-4	ACTUATOR, SW	412106	89536	412106	REF		
S51	SWITCH, ROTARY	429548	89536	429548	1	1	
U1	IC, TTL, LO-PWR, QUAD, "D" TYPE F/F	393215	01295	SN74S175N	7	2	
U2	IC, TTL, LO-PWR, QUAD, "D" TYPE F/F	393215	01295	SN74S175N	REF		
U3	IC, TTL, LO-PWR, QUAD, "D" TYPE F/F	393215	01295	SN74S175N	REF		
U4	IC, TTL, LO-PWR, QUAD, "D" TYPE F/F	393215	01295	SN74S175N	REF		
U5	IC, TTL, LO-PWR, QUAD, "D" TYPE F/F	393215	01295	SN74S175N	REF		
U6	IC, TTL, LO-PWR, QUAD, "D" TYPE F/F	393215	01295	SN74S175N	REF		

Table 5-16. A10 Front Panel PCB Assembly, Non-Storage (cont)

REF DES	DESCRIPTION	FLUKE STOCK NO.	MFG SPLY CODE	MFG PART NO. OR TYPE	TOT QTY	REC QTY	N O T E
U7	IC, TTL, DUAL PERIPHERAL DRIVER	329706	01295	SN75452P	10	2	
U8	IC, TTL, DUAL PERIPHERAL DRIVER	329706	01295	SN75452P	REF		
U9	IC, TTL, LO-PWR, QUAD, "D" TYPE F/F	393215	01295	SN74S175N	REF		
U10	IC, QUAD, 2-IN, HI-V POS NAND GATE	453167	01295	SN74LS26N	2	1	
U11	IC, QUAD, 2-IN, HI-V POS NAND GATE	453167	01295	SN74LS26N	REF		
U12	⊗ IC, C-MOS, RETRIGGER/RESET MULTIVIBRATOR	393512	02735	CD4098AE	1	1	
U13	IC, TTL, DUAL PERIPHERAL DRIVER	329706	01295	SN75452P	REF		
U14	IC, TTL, DUAL PERIPHERAL DRIVER	329706	01295	SN75452P	REF		
U15	IC, TTL, DUAL PERIPHERAL DRIVER	329706	01295	SN75452P	REF		
U16	IC, TTL, DUAL PERIPHERAL DRIVER	329706	01295	SN75452P	REF		
U17	IC, TTL, DUAL PERIPHERAL DRIVER	329706	01295	SN75452P	REF		
U18	IC, TTL, DUAL PERIPHERAL DRIVER	329706	01295	SN75452P	REF		
U19	IC, TTL, DUAL PERIPHERAL DRIVER	329706	01295	SN75452P	REF		
U20	IC, TTL, DUAL PERIPHERAL DRIVER	329706	01295	SN75452P	REF		
U21	IC, LIN, SI, DIODE ARRAYS	429464	01295	T1D122	1	1	
U22	⊗ IC, C-MOS, TRIPLE 3-INPUT NAND GATE	375147	02735	CD4023AE	2	1	
U23	⊗ IC, C-MOS, TRIPLE 3-INPUT NAND GATE	375147	02735	CD4023AE	REF		
U24	⊗ IC, C-MOS, HEX BUFFER/INVERTER	381830	02735	CD4050AE	2	1	
U25	⊗ IC, C-MOS, HEX BUFFER/INVERTER	381830	02735	CD4050AE	REF		
U26	⊗ IC, C-MOS, TRI-STATE, HEX, INV/BUFFERS	407759	12040	MM80C97N	2	1	
U27	⊗ IC, C-MOS, TRI-STATE, HEX, INV/BUFFERS	407759	12040	MM80C97N	REF		
U28	⊗ IC, C-MOS, DUAL 4-INPUT AND GATE	408799	02735	CD4082BE	1	1	

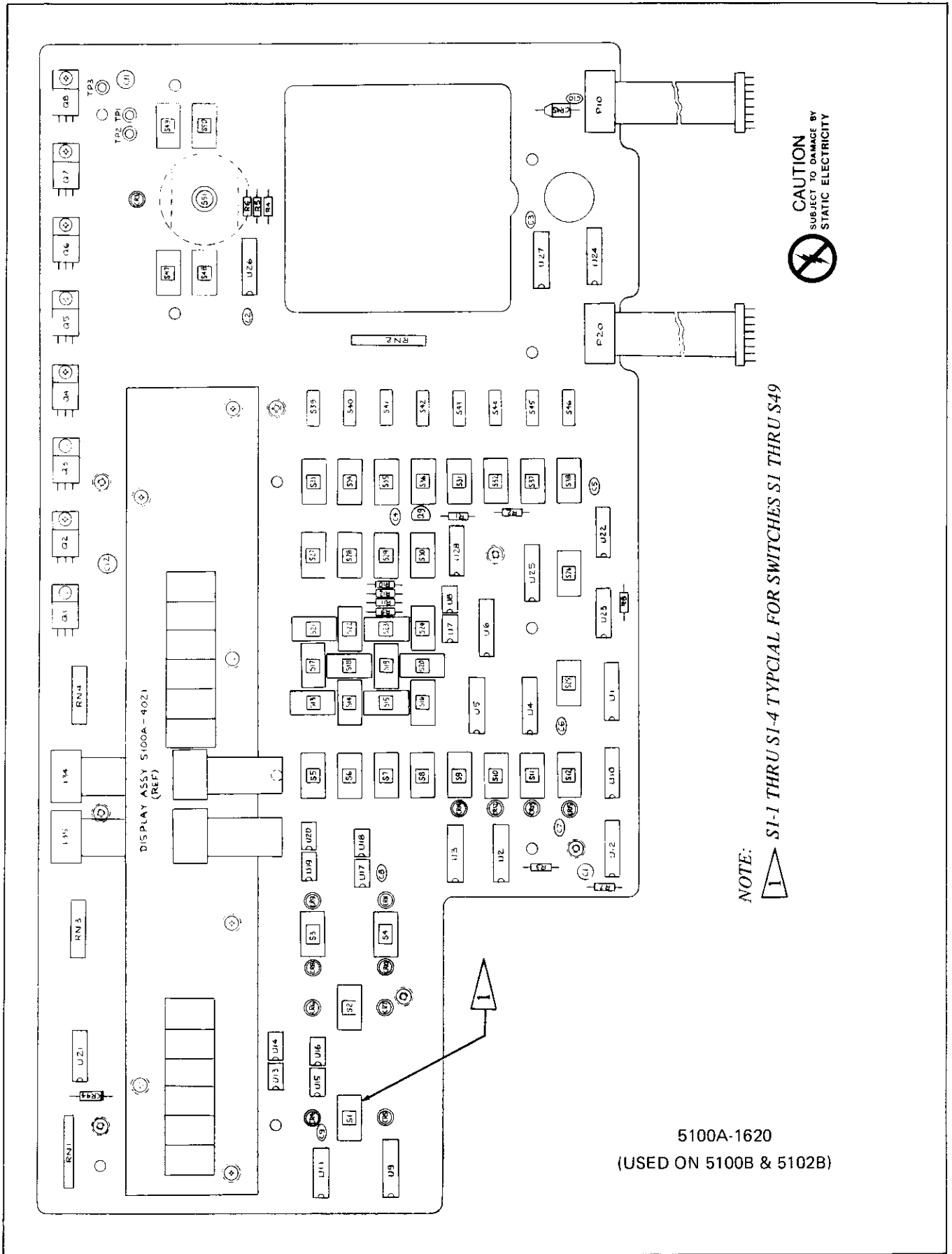

Figure 5-11. A10 Front Panel PCB Assembly, Non-Storage

Table 5-17. A10 Front Panel PCB Assembly, Storage

REF DES	DESCRIPTION	FLUKE STOCK NO.	MFG SPLY CODE	MFG PART NO. OR TYPE	TOT QTY	REC QTY	NOTE
A10	⊗ FRONT PANEL PCB ASSEMBLY FIGURE 5-12 (5101A-4020T)	459537	89536	459537	REF		
A10A1	DISPLAY PCB ASSEMBLY FIGURE 5-13 (5100A-4021)	456004	89536	456004	1		
C1	CAP, TA, 1 UF +/-20%, 35V	161919	56289	1960105X0035JA1	2		
C2	CAP, CER, 0.047 UF +/-20%, 40V	460733	71590	CW20C473M	8		
C3	CAP, CER, 0.047 UF +/-20%, 40V	460733	71590	CW20C473M	REF		
C4	CAP, CER, 0.047 UF +/-20%, 40V	460733	71590	CW20C473M	REF		
C5	CAP, CER, 0.047 UF +/-20%, 40V	460733	71590	CW20C473M	REF		
C6	CAP, CER, 0.047 UF +/-20%, 40V	460733	71590	CW20C473M	REF		
C7	CAP, TA, 1 UF +/-20%, 35V	161919	56289	1960105X0035JA1	REF		
C8	CAP, CER, 0.047 UF +/-20%, 40V	460733	71590	CW20C473M	REF		
C9	CAP, CER, 0.047 UF +/-20%, 40V	460733	71590	CW20C473M	REF		
C10	CAP, CER, 0.047 UF +/-20%, 40V	460733	71590	CW20C473M	REF		
C11	CAP, TA, 6.8UF +/-20%, 35V	363713	56289	1960685X0035KA1	2		
C12	CAP, TA, 6.8UF +/-20%, 35V	363713	56289	1960685X0035KA1	REF		
CR3	DIODE, LIGHT EMITTING	369777	28480	5082-4480	16	3	
CR4	DIODE, LIGHT EMITTING	369777	28480	5082-4480	REF		
CR5	DIODE, LIGHT EMITTING	369777	28480	5082-4480	REF		
CR6	DIODE, LIGHT EMITTING	369777	28480	5082-4480	REF		
CR7	DIODE, LIGHT EMITTING	369777	28480	5082-4480	REF		
CR8	DIODE, LIGHT EMITTING	369777	28480	5082-4480	REF		
CR9	DIODE, LIGHT EMITTING	369777	28480	5082-4480	REF		
CR10	DIODE, LIGHT EMITTING	369777	28480	5082-4480	REF		
CR11	DIODE, LIGHT EMITTING	369777	28480	5082-4480	REF		
CR12	DIODE, LIGHT EMITTING	369777	28480	5082-4480	REF		
CR13	DIODE, LIGHT EMITTING	369777	28480	5082-4480	REF		
CR14	DIODE, LIGHT EMITTING	369777	28480	5082-4480	REF		
CR15	DIODE, LIGHT EMITTING	369777	28480	5082-4480	REF		
CR16	DIODE, LIGHT EMITTING	369777	28480	5082-4480	REF		
CR17	DIODE, LIGHT EMITTING	369777	28480	5082-4480	REF		
CR18	DIODE, LIGHT EMITTING	369777	28480	5082-4480	REF		
CR44	DIODE, SI	343491	04713	IN4002	1	1	
CR45	DIODE, SI	347559	14099	IN5400	1		
H1	WASHER, LOCK INT	129957	78189	1220-05	1		
H2	WASHER, FLAT	110007	89536	110007	1		
H3	NUT, HEX, 3/8-32	129718	73734	9002-NP	1		
H4	NUT, HEX, 4-40	110635	89536	110635	8		
H5	SPACER, STANDOFF, 4-40	335604	89536	335604	7		
H6	SCREW, PHP, 4-40 X 1/4	129890	89536	129890	6		
H7	SCREW, PH, SEMS, 4-40 X 1/4	185918	89536	185918	8		
MP1	SPACER, STANDOFF, 6-32	296137	89536	296137	1		
MP3	DECAL	473397	89536	473397	1		
P10	CABLE ASSEMBLY, FLAT	428409	89536	428409	2		
P21	CABLE ASSY, FLAT	428409	89536	428409	REF		
Q1	XSTR, PWR NPN	386128	01295	T1P120	8	2	
Q2	XSTR, PWR NPN	386128	01295	T1P120	REF		
Q3	XSTR, PWR NPN	386128	01295	T1P120	REF		
Q4	XSTR, PWR NPN	386128	01295	T1P120	REF		

Table 5-17. A10 Front Panel PCB Assembly, Storage (cont)

REF DES	DESCRIPTION	FLUKE STOCK NO.	MFG SPLY CODE	MFG PART NO. OR TYPE	TOT QTY	REC QTY	NOTE
Q5	XSTR, PWR NPN	386128	01295	T1P120	REF		
Q6	XSTR, PWR NPN	386128	01295	T1P120	REF		
Q7	XSTR, PWR NPN	386128	01295	T1P120	REF		
Q8	XSTR, PWR NPN	386128	01295	T1P120	REF		
Q9	XSTR, SI, PNP	226290	04713	MPS3640	1	1	
R1	RES, DEP. CAR, 22K +/-5%, 1/4W	348870	80031	CR251-45P22KT	1		
R2	RES, DEP. CAR, 150 +/-5%, 1/4W	343442	80031	CR251-45P150ET	1		
R3	RES, DEP. CAR, 1K +/-5%, 1/4W	343426	80031	CR251-4P51KT	1		
R4	RES, DEP. CAR, 10K +/-5%, 1/4W	348839	80031	CR251-45P10KT	4		
R5	RES, DEP. CAR, 10K +/-5%, 1/4W	348839	80031	CR251-45P10KT	REF		
R6	RES, DEP. CAR, 10K +/-5%, 1/4W	348839	80031	CR251-45P10KT	REF		
R7	RES, DEP. CAR, 10K +/-5%, 1/4W	348839	80031	CR251-45P10KT	REF		
R8	RES, DEP. CAR, 47K +/-5%, 1/4W	348896	80031	CR251-45P47KT	1		
R9	RES, DEP. CAR, 33 +/-5%, 1/4W	414524	80031	CR251-45P33ET	4		
R10	RES, DEP. CAR, 33 +/-5%, 1/4W	414524	80031	CR251-45P33ET	REF		
R11	RES, DEP. CAR, 33 +/-5%, 1/4W	414524	80031	CR251-45P33ET	REF		
R12	RES, DEP. CAR, 33 +/-5%, 1/4W	414524	80031	CR251-45P33ET	REF		
RN1	RES, NETWORK, 2K	446880	89536	446880	1	1	
RN2	RES, NETWORK 10K	414003	89536	414003	1	1	
RN3	RES, NETWORK, 39 +/-5%, 1/4W	519348	89536	519348	2	1	
RN4	RES, NETWORK, 39 +/-5%, 1/4W	519348	89536	519348	REF		
S1	PUSHBUTTON, LIGHT GREY	401307	89536	401307	23		
S1-1	COVER, SW	401299	89536	401299	50		
S1-2	SPRING, SW, PB	414516	00779	62353-3	50		
S1-3	CONTACT, SW, PB	416875	00779	62380-4	50		
S1-4	ACTUATOR, SW	412106	89536	412106	50		
S2	PUSHBUTTON, LIGHT GREY	401307	89536	401307	REF		
S2-1	COVER, SW	401299	89536	401299	REF		
S2-2	SPRING, SW, PB	414516	00779	62353-3	REF		
S2-3	CONTACT, SW, PB	416875	00779	62380-4	REF		
S2-4	ACTUATOR, SW	412106	89536	412106	REF		
S3	PUSHBUTTON, DK GREY	406868	89536	406868	2		
S3-1	COVER, SW	401299	89536	401299	REF		
S3-2	SPRING, SW, PB	414516	00779	62353-3	REF		
S3-3	CONTACT, SW, PB	416875	00779	62380-4	REF		
S3-4	ACTUATOR, SW	412106	89536	412106	REF		
S4	PUSHBUTTON, DK GREY	406868	89536	406868	REF		
S4-1	COVER, SW	401299	89536	401299	REF		
S4-2	SPRING, SW, PB	414516	00779	62353-3	REF		
S4-3	CONTACT, SW, PB	416875	00779	62380-4	REF		
S4-4	ACTUATOR, SW	412106	89536	412106	REF		
S5	PUSHBUTTON, LIGHT GREY	401307	89536	401307	REF		
S5-1	COVER, SW	401299	89536	401299	REF		
S5-2	SPRING, SW, PB	414516	00779	62353-3	REF		
S5-3	CONTACT, SW, PB	416875	00779	62380-4	REF		
S5-4	ACTUATOR, SW	412106	89536	412106	REF		
S6	PUSHBUTTON, LIGHT GREY	401307	89536	401307	REF		
S6-1	COVER, SW	401299	89536	401299	REF		
S6-2	SPRING, SW, PB	414516	00779	62353-3	REF		
S6-3	CONTACT, SW, PB	416875	00779	62380-4	REF		

Table 5-17. A10 Front Panel PCB Assembly, Storage (cont)

REF DES	DESCRIPTION	FLUKE STOCK NO.	MFG SPLY CODE	MFG PART NO. OR TYPE	TOT QTY	REC QTY	NOTE
S6-4	ACTUATOR, SW	412106	89536	412106	REF		
S7	PUSHBUTTON, LIGHT GREY	401307	89536	401307	REF		
S7-1	COVER, SW	401299	89536	401299	REF		
S7-2	SPRING, SW, PB	414516	00779	62353-3	REF		
S7-3	CONTACT, SW, PB	416875	00779	62380-4	REF		
S7-4	ACTUATOR, SW	412106	89536	412106	REF		
S8	PUSHBUTTON, LIGHT GREY	401307	89536	401307	REF		
S8-1	COVER, SW	401299	89536	401299	REF		
S8-2	SPRING, SW, PB	414516	00779	62353-3	REF		
S8-3	CONTACT, SW, PB	416875	00779	62380-4	REF		
S8-4	ACTUATOR, SW	412106	89536	412106	REF		
S9	PUSHBUTTON, LIGHT GREY	401307	89536	401307	REF		
S9-1	COVER, SW	401299	89536	401299	REF		
S9-2	SPRING, SW, PB	414516	00779	62353-3	REF		
S9-3	CONTACT, SW, PB	416875	00779	62380-4	REF		
S9-4	ACTUATOR, SW	412106	89536	412106	REF		
S10	PUSHBUTTON, LIGHT GREY	401307	89536	401307	REF		
S10-1	COVER, SW	401299	89536	401299	REF		
S10-2	SPRING, SW, PB	414516	00779	62353-3	REF		
S10-3	CONTACT, SW, PB	416875	00779	62380-4	REF		
S10-4	ACTUATOR, SW	412106	89536	412106	REF		
S11	PUSHBUTTON, LIGHT GREY	401307	89536	401307	REF		
S11-1	COVER, SW	401299	89536	401299	REF		
S11-2	SPRING, SW, PB	414516	00779	62353-3	REF		
S11-3	CONTACT, SW, PB	416875	00779	62380-4	REF		
S11-4	ACTUATOR, SW	412106	89536	412106	REF		
S12	PUSHBUTTON, LIGHT GREY	401307	89536	401307	REF		
S12-1	COVER, SW	401299	89536	401299	REF		
S12-2	SPRING, SW, PB	414516	00779	62353-3	REF		
S12-3	CONTACT, SW, PB	416875	00779	62380-4	REF		
S12-4	ACTUATOR, SW	412106	89536	412106	REF		
S13	PUSHBUTTON, WHITE	406744	89536	406744	REF	12	
S13-1	COVER, SW	401299	89536	401299	REF		
S13-2	SPRING, SW, PB	414516	00779	62353-3	REF		
S13-3	CONTACT, SW, PB	416875	00779	62380-4	REF		
S13-4	ACTUATOR, SW	412106	89536	412106	REF		
S14	PUSHBUTTON, WHITE	406744	89536	406744	REF		
S14-1	COVER, SW	401299	89536	401299	REF		
S14-2	SPRING, SW, PB	414516	00779	62353-3	REF		
S14-3	CONTACT, SW, PB	416875	00779	62380-4	REF		
S14-4	ACTUATOR, SW	412106	89536	412106	REF		
S15	PUSHBUTTON, WHITE	406744	89536	406744	REF		
S15-1	COVER, SW	401299	89536	401299	REF		
S15-2	SPRING, SW, PB	414516	00779	62353-3	REF		
S15-3	CONTACT, SW, PB	416875	00779	62380-4	REF		
S15-4	ACTUATOR, SW	412106	89536	412106	REF		
S16	PUSHBUTTON, WHITE	406744	89536	406744	REF		
S16-1	COVER, SW	401299	89536	401299	REF		
S16-2	SPRING, SW, PB	414516	00779	62353-3	REF		
S16-3	CONTACT, SW, PB	416875	00779	62380-4	REF		

Table 5-17. A10 Front Panel PCB Assembly, Storage (cont)

REF DES	DESCRIPTION	FLUKE STOCK NO.	MFG SPLY CODE	MFG PART NO. OR TYPE	TOT QTY	REC QTY	N O T E
S16-4	ACTUATOR, SW	412106	89536	412106	REF		
S17	PUSHBUTTON, WHITE	406744	89536	406744	REF		
S17-1	COVER, SW	401299	89536	401299	REF		
S17-2	SPRING, SW, PB	414516	00779	62353-3	REF		
S17-3	CONTACT, SW, PB	416875	00779	62380-4	REF		
S17-4	ACTUATOR, SW	412106	89536	412106	REF		
S18	PUSHBUTTON, WHITE	406744	89536	406744	REF		
S18-1	COVER, SW	401299	89536	401299	REF		
S18-2	SPRING, SW, PB	414516	00779	62353-3	REF		
S18-3	CONTACT, SW, PB	416875	00779	62380-4	REF		
S18-4	ACTUATOR, SW	412106	89536	412106	REF		
S19	PUSHBUTTON, WHITE	406744	89536	406744	REF		
S19-1	COVER, SW	401299	89536	401299	REF		
S19-2	SPRING, SW, PB	414516	00779	62353-3	REF		
S19-3	CONTACT, SW, PB	416875	00779	62380-4	REF		
S19-4	ACTUATOR, SW	412106	89536	412106	REF		
S20	PUSHBUTTON, WHITE	406744	89536	406744	REF		
S20-1	COVER, SW	401299	89536	401299	REF		
S20-2	SPRING, SW, PB	414516	00779	62353-3	REF		
S20-3	CONTACT, SW, PB	416875	00779	62380-4	REF		
S20-4	ACTUATOR, SW	412106	89536	412106	REF		
S21	PUSHBUTTON, WHITE	406744	89536	406744	REF		
S21-1	COVER, SW	401299	89536	401299	REF		
S21-2	SPRING, SW, PB	414516	00779	62353-3	REF		
S21-3	CONTACT, SW, PB	416875	00779	62380-4	REF		
S21-4	ACTUATOR, SW	412106	89536	412106	REF		
S22	PUSHBUTTON, WHITE	406744	89536	406744	REF		
S22-1	COVER, SW	401299	89536	401299	REF		
S22-2	SPRING, SW, PB	414516	00779	62353-3	REF		
S22-3	CONTACT, SW, PB	416875	00779	62380-4	REF		
S22-4	ACTUATOR, SW	412106	89536	412106	REF		
S23	PUSHBUTTON, WHITE	406744	89536	406744	REF		
S23-1	COVER, SW	401299	89536	401299	REF		
S23-2	SPRING, SW, PB	414516	00779	62353-3	REF		
S23-3	CONTACT, SW, PB	416875	00779	62380-4	REF		
S23-4	ACTUATOR, SW	412106	89536	412106	REF		
S24	PUSHBUTTON, WHITE	406744	89536	406744	REF		
S24-1	COVER, SW	401299	89536	401299	REF		
S24-2	SPRING, SW, PB	414516	00779	62353-3	REF		
S24-3	CONTACT, SW, PB	416875	00779	62380-4	REF		
S24-4	ACTUATOR, SW	412106	89536	412106	REF		
S25	PUSHBUTTON, SQ, BLUE	406736	89536	406736	1		
S25-1	COVER, SW	401299	89536	401299	REF		
S25-2	SPRING, SW, PB	414516	00779	62353-3	REF		
S25-3	CONTACT, SW, PB	416875	00779	62380-4	REF		
S25-4	ACTUATOR, SW	412106	89536	412106	REF		
S26	PUSHBUTTON, DK ORANGE	420620	89536	420620	1		
S26-1	COVER, SW	401299	89536	401299	REF		
S26-2	SPRING, SW, PB	414516	00779	62353-3	REF		
S26-3	CONTACT, SW, PB	416875	00779	62380-4	REF		

Table 5-17. A10 Front Panel PCB Assembly, Storage (cont)

REF DES	DESCRIPTION	FLUKE STOCK NO.	MFG SPLY CODE	MFG PART NO. OR TYPE	TOT QTY	REC QTY	N O T E
S26-4	ACTUATOR, SW	412106	89536	412106	REF		
S27	PUSHBUTTON, LIGHT GREY	401307	89536	401307	REF		
S27-1	COVER, SW	401299	89536	401299	REF		
S27-2	SPRING, SW, PB	414516	00779	62353-3	REF		
S27-3	CONTACT, SW, PB	416875	00779	62380-4	REF		
S27-4	ACTUATOR, SW	412106	89536	412106	REF		
S28	PUSHBUTTON, LIGHT GREY	401307	89536	401307	REF		
S28-1	COVER, SW	401299	89536	401299	REF		
S28-2	COVER, SW	401299	89536	401299	REF		
S28-3	CONTACT, SW, PB	416875	00779	62380-4	REF		
S28-4	ACTUATOR, SW	412106	89536	412106	REF		
S29	PUSHBUTTON, LIGHT GREY	401307	89536	401307	REF		
S29-1	COVER, SW	401299	89536	401299	REF		
S29-2	SPRING, SW, PB	414516	00779	62353-3	REF		
S29-3	CONTACT, SW, PB	416875	00779	62380-4	REF		
S29-4	ACTUATOR, SW	412106	89536	412106	REF		
S30	PUSHBUTTON, LIGHT GREY	401307	89536	401307	REF		
S30-1	COVER, SW	401299	89536	401299	REF		
S30-2	SPRING, SW, PB	414516	00779	62353-3	REF		
S30-3	CONTACT, SW, PB	416875	00779	62380-4	REF		
S30-4	ACTUATOR, SW	412106	89536	412106	REF		
S31	PUSHBUTTON, LIGHT GREY	401307	89536	401307	REF		
S31-1	COVER, SW	401299	89536	401299	REF		
S31-2	SPRING, SW, PB	414516	00779	62353-3	REF		
S31-3	CONTACT, SW, PB	416875	00779	62380-4	REF		
S31-4	ACTUATOR, SW	412106	89536	412106	REF		
S32	PUSHBUTTON, LIGHT GREY	401307	89536	401307	REF		
S32-1	COVER, SW	401299	89536	401299	REF		
S32-2	SPRING, SW, PB	414516	00779	62353-3	REF		
S32-3	CONTACT, SW, PB	416875	00779	62380-4	REF		
S32-4	ACTUATOR, SW	412106	89536	412106	REF		
S33	PUSHBUTTON, LIGHT GREY	401307	89536	401307	REF		
S33-1	COVER, SW	401299	89536	401299	REF		
S33-2	SPRING, SW, PB	414516	00779	62353-3	REF		
S33-3	CONTACT, SW, PB	416875	00779	62380-4	REF		
S33-4	ACTUATOR, SW	412106	89536	412106	REF		
S34	PUSHBUTTON, LIGHT GREY	401307	89536	401307	REF		
S34-1	COVER, SW	401299	89536	401299	REF		
S34-2	SPRING, SW, PB	414516	00779	62353-3	REF		
S34-3	CONTACT, SW, PB	416875	00779	62380-4	REF		
S34-4	ACTUATOR, SW	412106	89536	412106	REF		
S35	PUSHBUTTON, LIGHT GREY	401307	89536	401307	REF		
S35-1	COVER, SW	401299	89536	401299	REF		
S35-2	SPRING, SW, PB	414516	00779	62353-3	REF		
S35-3	CONTACT, SW, PB	416875	00779	62380-4	REF		
S35-4	ACTUATOR, SW	412106	89536	412106	REF		
S36	PUSHBUTTON, LIGHT GREY	401307	89536	401307	REF		
S36-1	COVER, SW	401299	89536	401299	REF		
S36-2	SPRING, SW, PB	414516	00779	62353-3	REF		
S36-3	CONTACT, SW, PB	416875	00779	62380-4	REF		

Table 5-17. A10 Front Panel PCB Assembly, Storage (cont)

REF DES	DESCRIPTION	FLUKE STOCK NO.	MFG SPLY CODE	MFG PART NO. OR TYPE	TOT QTY	REC QTY	N O T E
S36-4	ACTUATOR, SW	412106	89536	412106	REF		
S37	PUSHBUTTON, SQ, DK GREY	406728	89536	406728	5		
S37-1	COVER, SW	401299	89536	401299	REF		
S37-2	SPRING, SW, PB	414516	00779	62353-3	REF		
S37-3	CONTACT, SW, PB	416875	00779	62380-4	REF		
S37-4	ACTUATOR, SW	412106	89536	412106	REF		
S38	PUSHBUTTON, SQ, DK GREY	406728	89536	406728	REF		
S38-1	COVER, SW	401299	89536	401299	REF		
S38-2	SPRING, SW, PB	414516	00779	62353-3	REF		
S38-3	CONTACT, SW, PB	416875	00779	62380-4	REF		
S38-4	ACTUATOR, SW	412106	89536	412106	REF		
S39	PUSHBUTTON, LIGHT GREY	401307	89536	401307	REF		
S39-1	COVER, SW	401299	89536	401299	REF		
S39-2	SPRING, SW, PB	414516	00779	62353-3	REF		
S39-3	CONTACT, SW, PB	416875	00779	62380-4	REF		
S39-4	ACTUATOR, SW	412106	89536	412106	REF		
S40	PUSHBUTTON, LIGHT GREY	401307	89536	401307	REF		
S40-1	COVER, SW	401299	89536	401299	REF		
S40-2	SPRING, SW, PB	414516	00779	62353-3	REF		
S40-3	CONTACT, SW, PB	416875	00779	62380-4	REF		
S40-4	ACTUATOR, SW	412106	89536	412106	REF		
S41	PUSHBUTTON, SMALL, YELLOW	419937	89536	419937	4		
S41-1	COVER, SW	401299	89536	401299	REF		
S41-2	SPRING, SW, PB	414516	00779	62353-3	REF		
S41-3	CONTACT, SW, PB	416875	00779	62380-4	REF		
S41-4	ACTUATOR, SW	412106	89536	412106	REF		
S42	PUSHBUTTON, LARGE, YELLOW	456053	89536	456053	1		
S42-1	COVER, SW	401299	89536	401299	REF		
S42-2	SPRING, SW, PB	414516	00779	62353-3	REF		
S42-3	CONTACT, SW, PB	416875	00779	62380-4	REF		
S42-4	ACTUATOR, SW	412106	89536	412106	REF		
S43	PUSHBUTTON, SMALL, YELLOW	419937	89536	419937	REF		
S43-1	COVER, SW	401299	89536	401299	REF		
S43-2	SPRING, SW, PB	414516	00779	62353-3	REF		
S43-3	CONTACT, SW, PB	416875	00779	62380-4	REF		
S43-4	ACTUATOR, SW	412106	89536	412106	REF		
S44	PUSHBUTTON, SMALL, YELLOW	419937	89536	419937	REF		
S44-1	COVER, SW	401299	89536	401299	REF		
S44-2	SPRING, SW, PB	414516	00779	62353-3	REF		
S44-3	CONTACT, SW, PB	416875	00779	62380-4	REF		
S44-4	ACTUATOR, SW	412106	89536	412106	REF		
S45	PUSHBUTTON, SMALL, YELLOW	419937	89536	419937	REF		
S45-1	COVER, SW	401299	89536	401299	REF		
S45-2	SPRING, SW, PB	414516	00779	62353-3	REF		
S45-3	CONTACT, SW, PB	416875	00779	62380-4	REF		
S45-4	ACTUATOR, SW	412106	89536	412106	REF		
S46	PUSHBUTTON, SQ, BLUE	406736	89536	406736	REF		
S46-1	COVER, SW	401299	89536	401299	REF		
S46-2	SPRING, SW, PB	414516	00779	62353-3	REF		
S46-3	CONTACT, SW, PB	416875	00779	62380-4	REF		

Table 5-17. A10 Front Panel PCB Assembly, Storage (cont)

REF DES	DESCRIPTION	FLUKE STOCK NO.	MFG SPLY CODE	MFG PART NO. OR TYPE	TOT QTY	REC QTY	NO TE
S46-4	ACTUATOR, SW	412106	89536	412106	REF		
S47	PUSHBUTTON, LIGHT GREY	401307	89536	401307	REF		
S47-1	COVER, SW	401299	89536	401299	REF		
S47-2	SPRING, SW, PB	414516	00779	62353-3	REF		
S47-3	CONTACT, SW, PB	416875	00779	62380-4	REF		
S47-4	ACTUATOR, SW	412106	89536	412106	REF		
S48	PUSHBUTTON, SQ, DK GREY	406728	89536	406728	REF		
S48-1	COVER, SW	401299	89536	401299	REF		
S48-2	SPRING, SW, PB	414516	00779	62353-3	REF		
S48-3	CONTACT, SW, PB	416875	00779	62380-4	REF		
S48-4	ACTUATOR, SW	412106	89536	412106	REF		
S49	PUSHBUTTON, SQ, DK GREY	406728	89536	406728	REF		
S49-1	COVER, SW	401299	89536	401299	REF		
S49-2	SPRING, SW, PB	414516	00779	62353-3	REF		
S49-3	CONTACT, SW, PB	416875	00779	62380-4	REF		
S49-4	ACTUATOR, SW	412106	89536	412106	REF		
S50	PUSHBUTTON, SQ, DK GREY	406728	89536	406728	REF		
S50-1	COVER, SW	401299	89536	401299	REF		
S50-2	SPRING, SW, PB	414516	00779	62353-3	REF		
S50-3	CONTACT, SW, PB	416875	00779	62380-4	REF		
S50-4	ACTUATOR, SW	412106	89536	412106	REF		
S51	SWITCH, ROTARY	429548	89536	429548	1	1	
U1	IC, TTL, LO-PWR, QUAD, "D" TYPE F/F	393215	01295	SN74S175N	7	2	
U2	IC, TTL, LO-PWR, QUAD, "D" TYPE F/F	393215	01295	SN74S175N	REF		
U3	IC, TTL, LO-PWR, QUAD, "D" TYPE F/F	393215	01295	SN74S175N	REF		
U4	IC, TTL, LO-PWR, QUAD, "D" TYPE F/F	393215	01295	SN74S175N	REF		
U5	IC, TTL, LO-PWR, QUAD, "D" TYPE F/F	393215	01295	SN74S175N	REF		
U6	IC, TTL, LO-PWR, QUAD, "D" TYPE F/F	393215	01295	SN74S175N	REF		
U7	IC, TTL, DUAL PERIPHERAL DRIVER	329706	01295	SN75452P	10	2	
U8	IC, TTL, DUAL PERIPHERAL DRIVER	329706	01295	SN75452P	REF		
U9	IC, TTL, LO-PWR, QUAD, "D" TYPE F/F	393215	01295	SN74S175N	REF		
U10	IC, QUAD, 2-IN, HI-V POS NAND GATE	453167	01295	SN74LS26N	2	1	
U11	IC, QUAD, 2-IN, HI-V POS NAND GATE	453167	01295	SN74LS26N	REF		
U12	⊗ IC, C-MOS, RETRIGGER/RESET MULTIVIBRATOR	393512	02735	CD4098AE	1	1	
U13	IC, TTL, DUAL PERIPHERAL DRIVER	329706	01295	SN75452P	REF		
U14	IC, TTL, DUAL PERIPHERAL DRIVER	329706	01295	SN75452P	REF		
U15	IC, TTL, DUAL PERIPHERAL DRIVER	329706	01295	SN75452P	REF		
U16	IC, TTL, DUAL PERIPHERAL DRIVER	329706	01295	SN75452P	REF		
U17	IC, TTL, DUAL PERIPHERAL DRIVER	329706	01295	SN75452P	REF		
U18	IC, TTL, DUAL PERIPHERAL DRIVER	329706	01295	SN75452P	REF		
U19	IC, TTL, DUAL PERIPHERAL DRIVER	329706	01295	SN75452P	REF		
U20	IC, TTL, DUAL PERIPHERAL DRIVER	329706	01295	SN75452P	REF		
U21	IC, LIN, SI, DIODE ARRAYS	429464	01295	T1D122	1	1	
U22	⊗ IC, C-MOS, TRIPLE 3-INPUT NAND GATE	375147	02735	CD4023AE	2	1	
U23	⊗ IC, C-MOS, TRIPLE 3-INPUT NAND GATE	375147	02735	CD4023AE	REF		
U24	⊗ IC, C-MOS, HEX BUFFER/INVERTER	381830	02735	CD4050AE	2	1	
U25	⊗ IC, C-MOS, HEX BUFFER/INVERTER	381830	02735	CD4050AE	REF		
U26	⊗ IC, C-MOS, TRI-STATE, HEX, INV/BUFFERS	407759	12040	MM80C97N	2	1	
U27	⊗ IC, C-MOS, TRI-STATE, HEX, INV/BUFFERS	407759	12040	MM80C97N	REF		
U28	⊗ IC, C-MOS, DUAL 4-INPUT AND GATE	408799	02735	CD4082BE	1	1	

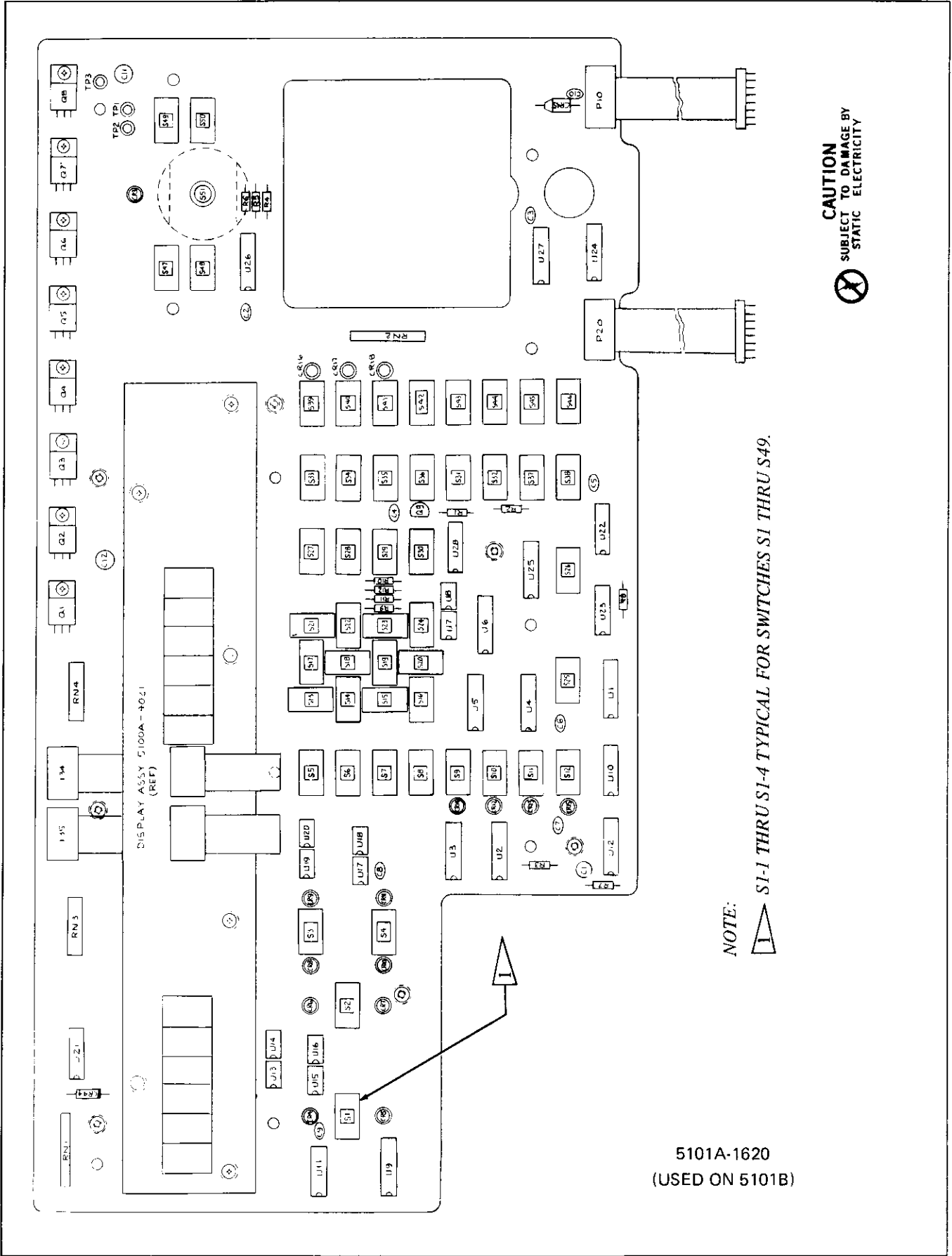
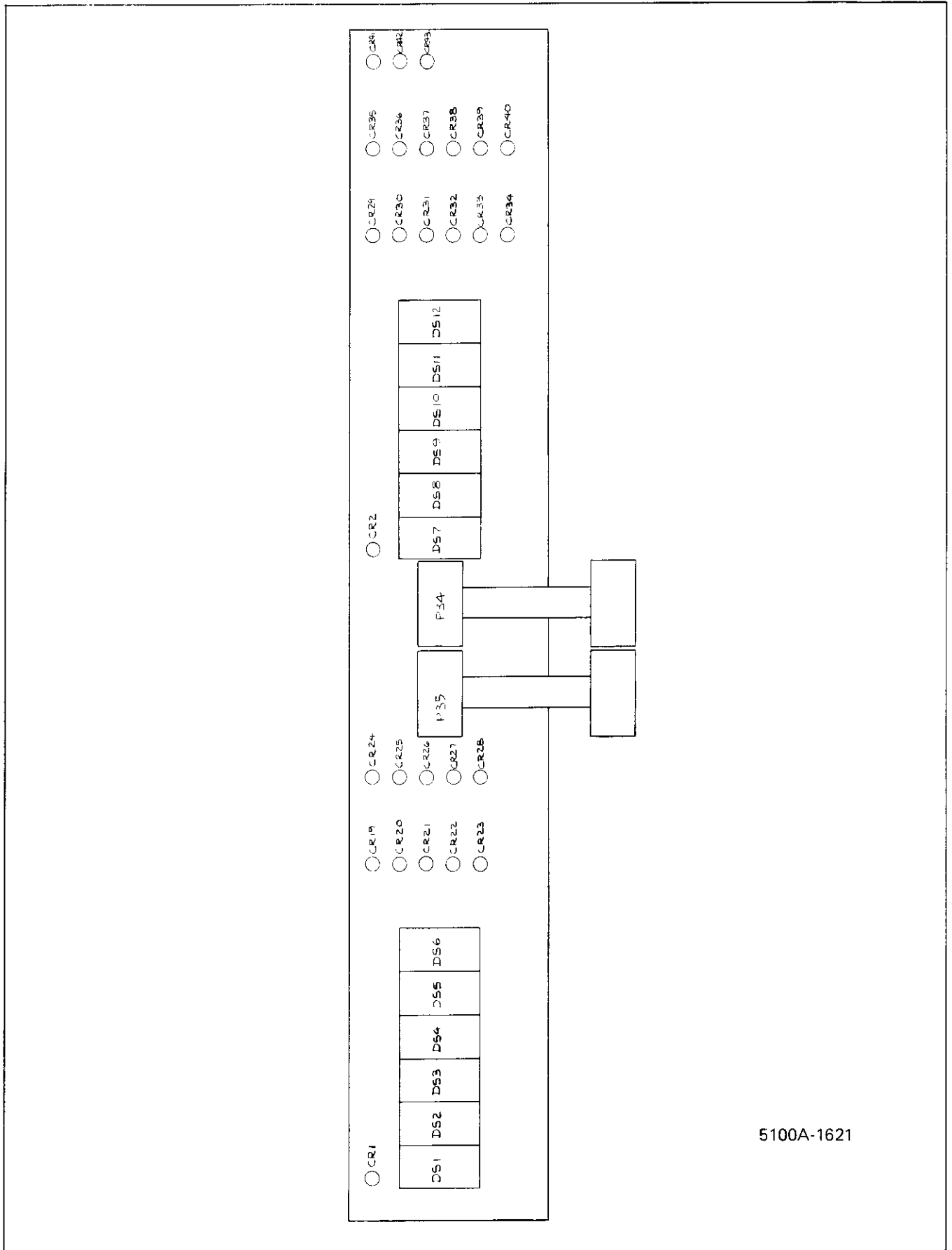

Figure 5-12. A10 Front Panel PCB Assembly, Storage (cont)

Table 5-18. A10A1 Display PCB Assembly

REF DES	DESCRIPTION	FLUKE STOCK NO.	MFG SPLY CODE	MFG PART NO. OR TYPE	TOT QTY	REC QTY	NOTE
A10A1	DISPLAY PCB ASSEMBLY FIGURE 5-13 (5100A-4021)	456004	89536	456004	REF		
CR19	DIODE, LIGHT EMITTING, LED	369777	28480	5082-4480	27	10	
CR20	DIODE, LIGHT EMITTING, LED	369777	28480	5082-4480	REF		
CR21	DIODE, LIGHT EMITTING, LED	369777	28480	5082-4480	REF		
CR22	DIODE, LIGHT EMITTING, LED	369777	28480	5082-4480	REF		
CR23	DIODE, LIGHT EMITTING, LED	369777	28480	5082-4480	REF		
CR24	DIODE, LIGHT EMITTING, LED	369777	28480	5082-4480	REF		
CR25	DIODE, LIGHT EMITTING, LED	369777	28480	5082-4480	REF		
CR26	DIODE, LIGHT EMITTING, LED	369777	28480	5082-4480	REF		
CR27	DIODE, LIGHT EMITTING, LED	369777	28480	5082-4480	REF		
CR28	DIODE, LIGHT EMITTING, LED	369777	28480	5082-4480	REF		
CR29	DIODE, LIGHT EMITTING, LED	369777	28480	5082-4480	REF		
CR30	DIODE, LIGHT EMITTING, LED	369777	28480	5082-4480	REF		
CR31	DIODE, LIGHT EMITTING, LED	369777	28480	5082-4480	REF		
CR32	DIODE, LIGHT EMITTING, LED	369777	28480	5082-4480	REF		
CR33	DIODE, LIGHT EMITTING, LED	369777	28480	5082-4480	REF		
CR34	DIODE, LIGHT EMITTING, LED	369777	28480	5082-4480	REF		
CR35	DIODE, LIGHT EMITTING, LED	369777	28480	5082-4480	REF		
CR36	DIODE, LIGHT EMITTING, LED	369777	28480	5082-4480	REF		
CR37	DIODE, LIGHT EMITTING, LED	369777	28480	5082-4480	REF		
CR38	DIODE, LIGHT EMITTING, LED	369777	28480	5082-4480	REF		
CR39	DIODE, LIGHT EMITTING, LED	369777	28480	5082-4480	REF		
CR40	DIODE, LIGHT EMITTING, LED	369777	28480	5082-4480	REF		
CR41	DIODE, LIGHT EMITTING, LED	369777	28480	5082-4480	REF		
CR42	DIODE, LIGHT EMITTING, LED	369777	28480	5082-4480	REF		
CR43	DIODE, LIGHT EMITTING, LED	369777	28480	5082-4480	REF		
DS1	DISPLAY, LED, COMMON ANODE	472951	28480	QDSP3011	2	1	
DS2	DISPLAY, LED, SEVEN SEGMENT	472944	28480	QDSP3016	10	5	
DS3	DISPLAY, LED, SEVEN SEGMENT	472944	28480	QDSP3016	REF		
DS4	DISPLAY, LED, SEVEN SEGMENT	472944	28480	QDSP3016	REF		
DS5	DISPLAY, LED, SEVEN SEGMENT	472944	28480	QDSP3016	REF		
DS6	DISPLAY, LED, SEVEN SEGMENT	472944	28480	QDSP3016	REF		
DS7	DISPLAY, LED, COMMON ANODE	472951	28480	QDSP3011	REF		
DS8	DISPLAY, LED, SEVEN SEGMENT	472944	28480	QDSP3016	REF		
DS9	DISPLAY, LED, SEVEN SEGMENT	472944	28480	QDSP3016	REF		
DS10	DISPLAY, LED, SEVEN SEGMENT	472944	28480	QDSP3016	REF		
DS11	DISPLAY, LED, SEVEN SEGMENT	472944	28480	QDSP3016	REF		
DS12	DISPLAY, LED, SEVEN SEGMENT	472944	28480	QDSP3016	REF		
P34	CABLE ASSY, FLAT	447555	08261	5612-003.75	2		
P35	CABLE ASSY, FLAT	447555	08261	5612-003.75	REF		



5100A-1621

Figure 5-13. A10A1 Display PCB Assembly

Table 5-19. A11 Ranging PCB Assembly

REF DES	DESCRIPTION	FLUKE STOCK NO.	MFG SPLY CODE	MFG PART NO. OR TYPE	TOT QTY	REC QTY	NOTE
A11	⊗ RANGING PCB ASSEMBLY FIGURE 5-14 (5100A-4040T)	458414	89536	458414	REF		
BP1	BINDING POST, BLACK	380154	32767	825-45	2		
BP2	BINDING POST, RED	380147	32767	825-65	2		
BP3	BINDING POST, BLUE	275578	32767	820-55	1		
BP4	BINDING POST, VIOLET	424481	32767	820-85	1		
C1	CAP, VAR, MINI, 1.7-10 PF, 250V	375238	56289	GKC10000	1	1	1
C2	CAP, SELECTED				1		
C4	CAP, MICA, 82 PF +/-5%, 500V	148502	72136	DM15E820J	1		
C5	CAP, TA, 10 UF +/-20%, 20V	330662	56289	196106X0020KA1	8		
C6	CAP, TA, 10 UF +/-20%, 20V	330662	56289	196106X0020KA1	REF		
C7	CAP, MICA, 5 PF +/-5%, 500V	148577	72136	DM15C050K	1		
C8	CAP, CER, 0.22 UF +/-20%, 50V	309849	71590	CW30C224K	2		
C9	CAP, CER, 0.22 UF +/-20%, 50V	309849	71590	CW30C224K	REF		
C10	CAP, TA, 47 UF +/-20%, 20V	348516	56289	196D476X0020TE4	1		
C11	CAP, TA, 10 UF +/-20%, 20V	330662	56289	196106X0020KA1	REF		
C12	CAP, TA, 10 UF +/-20%, 20V	330662	56289	196106X0020KA1	REF		
C13	CAP, TA, 10 UF +/-20%, 20V	330662	56289	196106X0020KA1	REF		
C14	CAP, TA, 10 UF +/-20%, 20V	330662	56289	196106X0020KA1	REF		
C15	CAP, VAR, CER, 5-50 PF, 250V	404301	52769	GKD50000	1	1	
C16	CAP, TA, 10 UF +/-20%, 20V	330662	56289	196106X0020KA1	REF		
C17	CAP, TA, 10 UF +/-20%, 20V	330662	56289	196106X0020KA1	REF		
C18	CAP, SELECTED				1		1
C19	CAP, CER, 500 PF +/-10%, 1 KV	105692	71590	2DDH60N501K	10		
C20	CAP, SELECTED				1		1
C21	CAP, CER, 500 PF +/-10%, 1 KV	105692	71590	2DDH60N501K	REF		
C22	CAP, CER, 500 PF +/-10%, 1 KV	105692	71590	2DDH60N501K	REF		
C23	CAP, CER, 500 PF +/-10%, 1 KV	105692	71590	2DDH60N501K	REF		
C24	CAP, CER, 500 PF +/-10%, 1 KV	105692	71590	2DDH60N501K	REF		
C25	CAP, CER, 500 PF +/-10%, 1 KV	105692	71590	2DDH60N501K	REF		
C26	CAP, CER, 500 PF +/-10%, 1 KV	105692	71590	2DDH60N501K	REF		
C27	CAP, CER, 500 PF +/-10%, 1 KV	105692	71590	2DDH60N501K	REF		
C28	CAP, CER, 500 PF +/-10%, 1 KV	105692	71590	2DDH60N501K	REF		
C29	CAP, CER, 500 PF +/-10%, 1 KV	105692	71590	2DDH60N501K	REF		
C31	CAP, MICA, 2 PF +/-0.5 PF, 500V	175208	72136	DM15C020D	1		
C33	CAP, MICA, 20 PF +/-5%, 500V	446658	72136	DN15C200J	2		
C34	CAP, MICA, 20 PF +/-5%, 500V	446658	72136	DN15C200J	REF		
CR1	DIODE, SI, HI-SPEED SWITCHING	203323	07910	IN4448	27	6	
CR2	DIODE, SI, HI-SPEED SWITCHING	203323	07910	IN4448	REF		
CR3	DIODE, SI, RECTIFIER	347559	05277	IN5400	2	1	
CR4	DIODE, SI, RECTIFIER	347559	05277	IN5400	REF		
CR5	DIODE, SI, HI-SPEED SWITCHING	203323	07910	IN4448	REF		
CR6	DIODE, SI, HI-SPEED SWITCHING	203323	07910	IN4448	REF		
CR7	DIODE, SI, HI-SPEED SWITCHING	203323	07910	IN4448	REF		
CR8	DIODE, SI, HI-SPEED SWITCHING	203323	07910	IN4448	REF		
CR9	DIODE, SI, HI-SPEED SWITCHING	203323	07910	IN4448	REF		
CR10	DIODE, SI, HI-SPEED SWITCHING	203323	07910	IN4448	REF		
CR11	DIODE, SI, HI-SPEED SWITCHING	203323	07910	IN4448	REF		
CR12	DIODE, SI, HI-SPEED SWITCHING	203323	07910	IN4448	REF		

Table 5-19. A11 Ranging PCB Assembly (cont)

REF DES	DESCRIPTION	FLUKE STOCK NO.	MFG SPLY CODE	MFG PART NO. OR TYPE	TOT QTY	REC QTY	N O T E
CR13	DIODE, SI, HI-SPEED SWITCHING	203323	07910	IN4448	REF		
CR14	DIODE, SI, HI-SPEED SWITCHING	203323	07910	IN4448	REF		
CR15	DIODE, SI, HI-SPEED SWITCHING	203323	07910	IN4448	REF		
CR16	DIODE, SI, HI-SPEED SWITCHING	203323	07910	IN4448	REF		
CR17	DIODE, SI, HI-SPEED SWITCHING	203323	07910	IN4448	REF		
CR18	DIODE, SI, HI-SPEED SWITCHING	203323	07910	IN4448	REF		
CR19	DIODE, SI, HI-SPEED SWITCHING	203323	07910	IN4448	REF		
CR20	DIODE, SI, HI-SPEED SWITCHING	203323	07910	IN4448	REF		
CR21	DIODE, SI, HI-SPEED SWITCHING	203323	07910	IN4448	REF		
CR22	DIODE, SI, HI-SPEED SWITCHING	203323	07910	IN4448	REF		
CR23	DIODE, SI, HI-SPEED SWITCHING	203323	07910	IN4448	REF		
CR24	DIODE, SI, HI-SPEED SWITCHING	203323	07910	IN4448	REF		
CR25	DIODE, SI, LOW-CAP, LOW LEAKAGE	348177	07263	FD7223	2	1	
CR26	DIODE, SI, LOW-CAP, LOW LEAKAGE	348177	07263	FD7223	REF		
CR27	DIODE, SI, HI-SPEED SWITCHING	203323	07910	IN4448	REF		
CR28	DIODE, SI, HI-SPEED SWITCHING	203323	07910	IN4448	REF		
CR29	DIODE, SI, HI-SPEED SWITCHING	203323	07910	IN4448	REF		
CR50	DIODE, SI, HI-SPEED SWITCHING	203323	07910	IN4448	REF		
CR51	DIODE, SI, HI-SPEED SWITCHING	203323	07910	IN4448	REF		
E1	TERMINAL, FEED THRU	281865	12615	SL841777	11		
E3	STANDOFF, TERM, TEFLON	271650	12615	SL890823	3		
E4	INSULATOR, BND POST	421867	89536	421867	1		
H1	WASHER, SHOULDER #6	110387	86928	5604-47	3		
H2	SCREW, PHP SEMS, 6-32 X 3/8	177022	89536	177022	6		
H3	SCREW, PHP, 4-40 X 5/16	152116	89536	152116	2		
H4	SCREW, PHP, 2-56 X 3/8	146803	73734	22204	1		
H5	SPACER, HEX, 6-32 X 3/8	417493	89536	417493	3		
H6	SCREW, FHP, UNDERCUT	271817	89536	271817	2		
K1	RELAY, TELE, 4P-DT	422931	77342	R10-E3713-3	1		
K3	RELAY, DRY REED, DPST	442921	21317	052A5 300BAA	2		
K4	RELAY, TELE, 2PDT	514240	89536	514240	5		
K5	RELAY, TELE, 2PDT	514240	89536	514240	REF		
K6	RELAY, TELE, 2PDT	514240	89536	514240	REF		
K7	RELAY, TELE, 2PDT	514240	89536	514240	REF		
K8	RELAY, DRY REED, DPST	340638	71482	MRB2A05	6		
K9	RELAY, DRY REED, HV SWITCH	441949	71707	UF-40094	2		
K10	RELAY, DRY REED, HV SWITCH	441949	71707	UF-40094	REF		
K12	RELAY, DRY REED, HV, LO-THERM EMF	423707	21317	PA181015-5	2		
K13	RELAY, DRY REED, DPST	340638	71482	MRB2A05	REF		
K14	RELAY, DRY REED, HV, LO-THERM EMF	423707	21317	PA181015-5	REF		
K16	RELAY, DRY REED	404590	71707	CR4503	2		
K17	RELAY, DRY REED, DPST	340638	71482	MRB2A05	REF		
K18	RELAY, DRY REED	404590	71707	CR4503	REF		
K50	RELAY, DRY REED, DPST	340638	71482	MRB2A05	REF		
K51	RELAY, DRY REED, DPST	340638	71482	MRB2A05	REF		
K52	RELAY, DRY REED, DPST	340638	71482	MRB2A05	REF		
K53	RELAY, DRY REED, SPST	357558	71707	UF40068	2		
K54	RELAY, DRY REED, SPST	357558	71707	UF40068	REF		
K55	RELAY, DRY REED, DPST	442921	21317	052A5 300BAA	REF		
K56	RELAY, TELE, 2PDT	514240	89536	514240	REF		

Table 5-19. A11 Ranging PCB Assembly (cont)

REF DES	DESCRIPTION	FLUKE STOCK NO.	MFG SPLY CODE	MFG PART NO. OR TYPE	TOT QTY	REC QTY	NOTE
K57	RELAY, ENCLOSED, DRY REED LO-THERM EMF	404061	71707	CR-3201-5-710	1		
L1	CHOKE, 6-TURN	320911	89536	320911	4		
L2	CHOKE, 6-TURN	320911	89536	320911	REF		
L3	CHOKE, 3-TURN	425888	89536	425888	1		
L4	CHOKE, 6-TURN	320911	89536	320911	REF		
L5	CHOKE, 6 TURN	320911	89536	320911	REF		
L8	INDUCTOR, CORE, FERRITE	460659	25088	B62110-J1021-X025	1		
L9	INDUCTOR, CORE, FERRITE	414268	89536	414268	2		
L10	INDUCTOR, CORE, FERRITE	414268	89536	414268	REF		
MP1	CABLE TIE	172080	06383	SST-1M	5		
MP2	FENCE, HIGH VOLTAGE, RANGING	426916	89536	426916	1		
MP5	BRACKET, HIGH VOLTAGE CONNECTOR	426205	89536	426205	1		
MP6	SPACER, TERM MTG	421859	89536	421859	1		
P43	CONNECTOR, HIGH VOLTAGE	442897	91637	G16P-AB	1		
P44	CONN, COAX, SNAP-ON RECPT-PCB MNT	353243	98291	51-053-0000	1		
Q1	XSTR, FET, N-CHANNEL	370072	89536	370072	2	1	
Q2	XSTR, FET, N-CHANNEL	370072	89536	370072	REF		
Q3	XSTR, SI, PNP	226290	04713	MPS3640	1	1	
Q4	XSTR, SI, NPN	218396	04713	2N3904	1	1	
Q5	XSTR, FET-JUNCTION, N-CHANNEL	376475	89536	376475	2	1	
Q6	XSTR, FET-JUNCTION, N-CHANNEL	376475	89536	376475	REF		
R1	RES, WW, 1.0033	421131	89536	421131	1	1	
R2	RES, VAR, CERMET, 200 +/-20%, 1/2W	284711	11236	190PC201B	2	1	
R3	RES, MTL. FILM, 210 +/-1%, 1/8W	327999	91637	CMF552100F	1		
R4	RES, WW, 9.0286	421149	89536	421149	1	1	
R5	RES, VAR, CERMET, 2K +/-20%, 1/2W	267864	11236	190PC202B	1	1	
R6	RES, MTL. FILM, 1.96K +/-1%, 1/8W	288423	91637	CMF551961F	1		
R7	RES, WW, 90.202	421156	89536	421156	1	1	
R8	RES, VAR, CERMET, 20K +/-20%, 1/2W	267898	11236	190PC203B	1	1	
R9	RES, MTL. FILM, 31.6K +/-1%, 1/8W	261610	91637	CMF553162F	1		
R10	RES, WW, 901.28	421164	89536	421164	1	1	
R11	RES, VAR, CERMET, 200K +/-20%, 1/2W	381509	11236	190PC204B	2	1	
R12	RES, MTL. FILM, 549K +/-1%, 1/8W	375964	91637	CMF555493F	1		
R13	RES, WW, 9027.4	421172	89536	421172	1	1	
R14	RES, VAR, CERMET, 500K +/-20%, 1/2W	288753	11236	190PC504B	3	1	
R15	RES, MTL. FILM, 2.8M +/-1%, 1/2W	236703	91637	CMF652804F	1		
R16	RES, VAR, CERMET, 500K +/-20%, 1/2W	288753	11236	190PC504B	REF		
R17	RES, MTL. FILM, 806K +/-1%, 1/8W	217976	91637	CMF558063F	1	1	
R18	RES, MTL. FILM, 107K +/-1%, 1/8W	288399	91637	CMF551073F	1		
R19	RES, VAR, CERMET, 100K +/-20%, 1/2W	268581	11236	190PC104B	1	1	
R20	RES, DEP. CAR, 10K +/-5%, 1/4W	348839	80031	CR251-4-5P10KT	6	1	
R21	RES, MTL. FILM, 8.987M +/-0.1%, 2W	417501	91637	MF289873B	1		
R22	RES, VAR, CERMET, 25K +/-20%, 1/2W	285213	11236	190PC253B	1		
R23	RES, SET, 900K (SET OF 4 RESISTORS)	425918	89536	425918	1	1	
R24	RES, SET, 900K (SET OF 4 RESISTORS)	425918	89536	425918	REF		
R25	RES, SET, 900K (SET OF 4 RESISTORS)	425918	89536	425918	REF		
R26	RES, SET, 900K (SET OF 4 RESISTORS)	425918	89536	425918	REF		
R27	RES, VAR, CERMET, 1K +/-20%, 1/2W	267856	11236	190PC102B	1	1	
R28	RES, WW, 49.977K	421388	89536	421388	1	1	
R29	RES, DEP. CAR, 10K +/-5%, 1/4W	348839	80031	CR251-4-5P10KT	REF		

Table 5-19. A11 Ranging PCB Assembly (cont)

REF DES	DESCRIPTION	FLUKE STOCK NO.	MFG SPLY CODE	MFG PART NO. OR TYPE	TOT QTY	REC QTY	NO TE
R30	RES, VAR, CERMET, 50 +/-20%, 1/2W	267815	11236	190PC500B	2	1	
R31	RES, WW, 44.977K	421370	90536	421370	1	1	
R32	RES, DEP. CAR, 1K +/-5%, 1/4W	343426	80031	CR251-4-5P1KT	5	1	
R33	RES, VAR, CERMET, 50 +/-20%, 1/2W	267815	11236	190PC500B	REF		
R34	RES, WW, 4.0118K	421354	89536	421354	1	1	
R35	RES, MTL. FILM, 1.13M +/-1%, 1/2W	221556	91637	CMF651134	1		
R36	RES, MTL. FILM, 332K +/-1%, 1/8W	289504	91637	CMF553323F	1		
R37	RES, VAR, CERMET, 500K +/-20%, 1/2W	288753	11236	190PC504B	REF		
R38	RES, VAR, CERMET, 200K +/-20%, 1/2W	381509	11236	190PC204B	REF		
R39	RES, WW, 1.0024K	421347	89536	421347	1	1	
R40	RES, DEP. CAR, 22K +/-5%, 1/4W	348870	80031	CR251-4-5P22KT	5	1	
R41	RES, DEP. CAR, 22K +/-5%, 1/4W	348870	80031	CR251-4-5P22KT	REF		
R42	RES, DEP. CAR, 4.7K +/-5%, 1/4W	348821	80031	CR251-4-5P4K7T	2	1	
R43	RES, DEP. CAR, 470 +/-5%, 1/4W	343434	80031	CR251-4-5P470ET	1		
R44	RES, DEP. CAR, 47K +/-5%, 1/4W	348896	80031	CR251-4-5P47KT	2	1	
R45	RES, DEP. CAR, 47K +/-5%, 1/4W	348896	80031	CR251-4-5P47KT	REF		
R46	RES, DEP. CAR, 2.2K +/-5%, 1/4W	343400	80031	CR251-4-5P2K2T	2	1	
R47	RES, DEP. CAR, 1K +/-5%, 1/4W	343426	80031	CR251-4-5P1KT	REF		
R48	RES, DEP. CAR, 150 +/-5%, 1/4W	343442	80031	CR251-4-5P150ET	2	1	
R49	RES, DEP. CAR, 1K +/-5%, 1/4W	343426	80031	CR251-4-5P1KT	REF		
R50	RES, DEP. CAR, 220 +/-5%, 1/4W	342626	80031	CR251-4-5P220ET	1	1	
R51	RES, DEP. CAR, 1K +/-5%, 1/4W	343426	80031	CR251-4-5P1KT	REF		
R52	RES, DEP. CAR, 2.2K +/-5%, 1/4W	343400	80031	CR251-4-5P2K2T	REF		
R53	RES, DEP. CAR, 22K +/-5%, 1/4W	348870	80031	CR251-4-5P22KT	REF		
R54	RES, DEP. CAR, 22K +/-5%, 1/4W	348870	80031	CR251-4-5P22KT	REF		
R55	RES, VAR, CERMET, 200 +/-20%, 1/2W	284711	11236	190PC201B	REF		
R57	RES, DEP. CAR, 1K +/-5%, 1/4W	343426	80031	CR251-4-5P1KT	REF		
R58	RES, DEP. CAR, 1.5K +/-5%, 1/4W	343418	80031	CR251-4-5P1K5T	1	1	
R59	RES, DEP. CAR, 10K +/-5%, 1/4W	348839	80031	CR251-4-5P10KT	REF		
R60	RES, DEP. CAR, 22K +/-5%, 1/4W	348870	80031	CR251-4-5P22KT	REF		
R61	RES, DEP. CAR, 150 +/-5%, 1/4W	343442	80031	CR251-4-5P150ET	REF		
R62	RES, DEP. CAR, 330 +/-5%, 1/4W	368720	80031	CR251-4-5P330ET	3	1	
R63	RES, DEP. CAR, 330 +/-5%, 1/4W	368720	80031	CR251-4-5P330ET	REF		
R64	RES, DEP. CAR, 330 +/-5%, 1/4W	368720	80031	CR251-4-5P330ET	REF		
R66	RES, WW, 44.910K	468595	89536	468595	1	1	
R67	RES, WW, 4.5202K	421362	89536	421362	1	1	
R68	RES, SET (R68,R69,R70,R71)	422337	89536	422337	1	1	
R69	RES, SET (R68,R69,R70,R71)	422337	89536	422337	REF		
R70	RES, SET (R68,R69,R70,R71)	422337	89536	422337	REF		
R71	RES, SET (R68,R69,R70,R71)	422337	89536	422337	REF		
R72	RES, DEP. CAR, 4.7K +/-5%, 1/4W	348821	80031	CR251-4-5P4K7T	REF		
R73	RES, DEP. CAR, 10K +/-5%, 1/4W	348839	80031	CR251-4-5P10KT	REF		
R74	RES, DEP. CAR, 10K +/-5%, 1/4W	348839	80031	CR251-4-5P10KT	REF		
R100	RES, DEP. CAR, 10K +/-5%, 1/4W	348839	80031	CR251-4-5P10KT	REF		
U1	IC, LINEAR, OP AMP	429837	12040	LF356H	1	1	
U2	IC, LINEAR, OP AMP	329912	12040	LM318H	1	1	
U3	⊗ IC, C-MOS, HEX BUFFER/INVERTERS	381830	02735	CD4050AE	2	1	
U4	⊗ IC, C-MOS, HEX BUFFER/INVERTERS	381830	02735	CD4050AE	REF		
U5	⊗ IC, C-MOS, AND GATE, TRIPLE 3-INPUT	418244	12040	MM74C10N	1	1	
U6	IC, TTL, LO-PWR, HEX/QUAD, "D" TYPE F/F	393207	01295	SN74LS174N	1	1	

Table 5-19. A11 Ranging PCB Assembly (cont)

REF DES	DESCRIPTION	FLUKE STOCK NO.	MFG SPLY CODE	MFG PART NO. OR TYPE	TOT QTY	REC QTY	N O T E
U7	IC, TTL, LO-PWR, HEX/QUAD, "D" TYPE F/F	393215	01295	SN74LS175N	4	1	
U8	IC, TTL, LO-PWR, HEX/QUAD, "D" TYPE F/F	393215	01295	SN74LS175N	REF		
U9	IC, TTL, LO-PWR, HEX/QUAD, "D" TYPE F/F	393215	01295	SN74LS175N	REF		
U10	IC, TTL, LO-PWR, HEX/QUAD, "D" TYPE F/F	393215	01295	SN74LS175N	REF		
U11	IC, LINEAR, DUAL PERIPHERAL DRIVER	329706	01295	SN75452P	3	1	
U12	IC, LINEAR, DUAL PERIPHERAL DRIVER	329706	01295	SN75452P	REF		
U13	IC, LINEAR, DUAL PERIPHERAL DRIVER	329706	01295	SN75452P	REF		
U14	IC, TTL, QUAD, 2-INPUT, POS NAND GATES	310201	01295	SN7438N	5	1	
U15	IC, TTL, QUAD, 2-INPUT, POS NAND GATES	310201	01295	SN7438N	REF		
U16	IC, TTL, QUAD, 2-INPUT, POS NAND GATES	310201	01295	SN7438N	REF		
U17	IC, TTL, QUAD, 2-INPUT, POS NAND GATES	310201	01295	SN7438N	REF		
U18	IC, TTL, QUAD, 2-INPUT, POS NAND GATES	310201	01295	SN7438N	REF		
U19	ISOLATOR, PHOTO, LED TO PHOT-RES	418699	18178	21L333	1	1	
U20	ISOLATOR, PHOTO, LOGIC DRIVE	454330	89536	454330	1	1	
VR1	DIODE, ZENER, UNCOMP N	267807	07910	IN970B	1	1	
VR2	DIODE, ZENER, 6.2V	325811	07910	1N753A	2	1	
VR3	DIODE, ZENER, 6.2V	325811	07910	1N753A	REF		
W1	CABLE, ASSY, RANGING S H	444976	89536	444976	1		
W2	CABLE ASSY, MV DIVIDER	444968	89536	444968	1		
W3	CABLE ASSEMBLY (TO A13, P114)	438226	89536	438226	1		
XK1	SOCKET, RELAY	441964	77342	R10273606	1		
XK4	SOCKET, RELAY	376665	77342	27E501	5		
XK5	SOCKET, RELAY	376665	77342	27E501	REF		
XK6	SOCKET, RELAY	376665	77342	27E501	REF		
XK7	SOCKET, RELAY	376665	77342	27E501	REF		
XK56	SOCKET, RELAY	376665	77342	27E501	REF		

1 SEE SEC. 4, PARA 5-114 TABLE 4-13

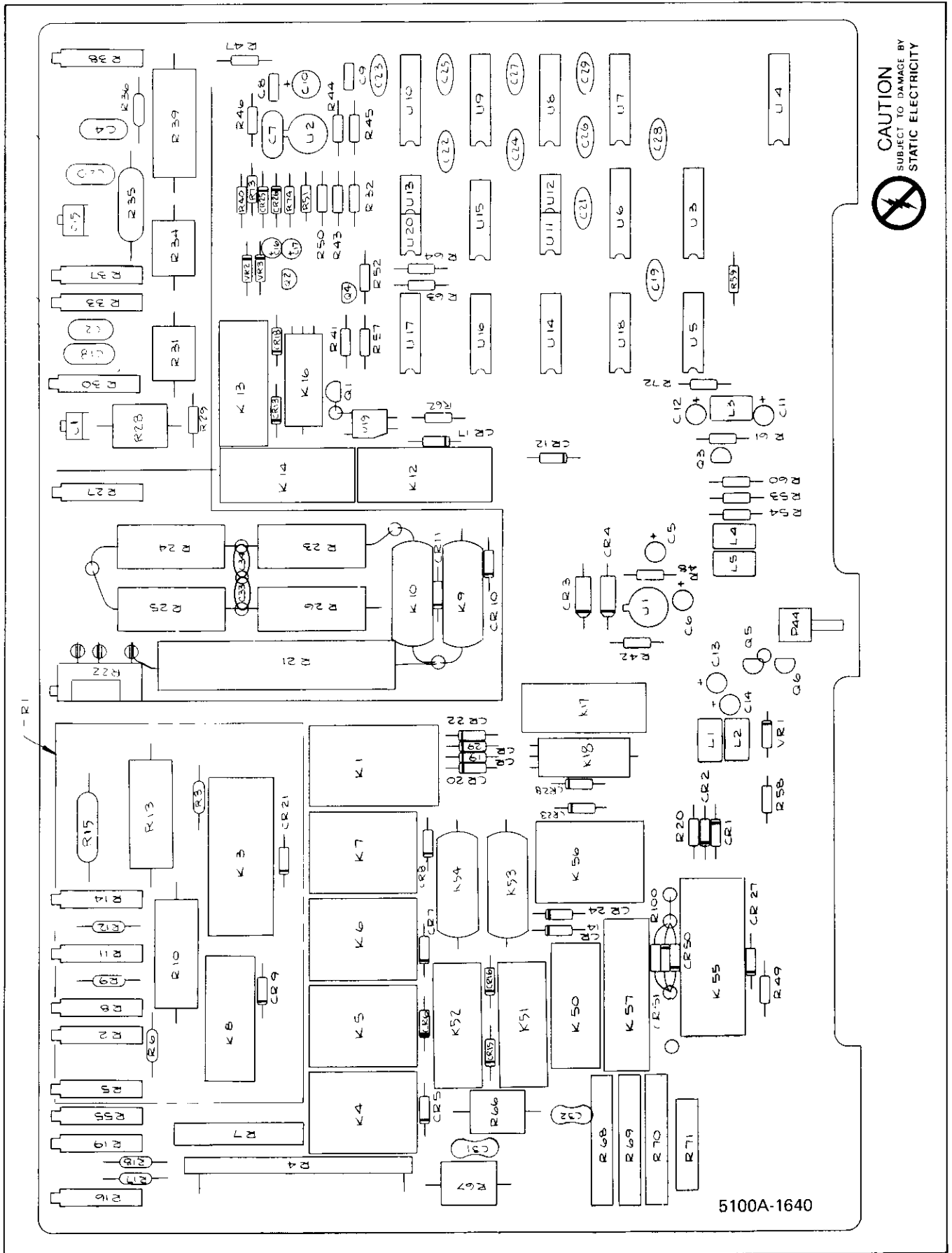

5100A-1640

CAUTION
SUBJECT TO DAMAGE BY
STATIC ELECTRICITY

Figure 5-14. A11 Ranging PCB Assembly

Table 5-20. A14 Analog Control PCB Assembly

REF DES	DESCRIPTION	FLUKE STOCK NO.	MFG SPLY CODE	MFG PART NO. OR TYPE	TOT QTY	REC QTY	N O T E
A14	⊗ ANALOG CONTROL PCB ASSEMBLY FIGURE 5-15 (5100A-4050T)	457705	89536	457705			REF
C1	CAP, MICA, 2700 PF +/-5%, 500V	148338	72136	DM19F272J		2	
C2	CAP, MICA, 620 PF +/-5%, 500V	215244	72136	DM19F621J		3	
C3	CAP, MICA, 620 PF +/-5%, 500V	215244	72136	DM19F621J			REF
C4	CAP, MICA, 2700 PF +/-5%, 500V	148338	72136	DM19F272J			REF
C5	CAP, MICA, 33 PF +/-5%, 500V	160317	72136	DM15E330J		3	
C6	CAP, MICA, 620PF +/-5%, 500V	215244	72136	DM19F621J			REF
C7	CAP, MICA, 1075 PF +/-1%, 500V	182899	72136	DM19F1075F		1	
C8	CAP, MICA, 5000 PF +/-5%, 500V	181065	72136	DM19F502J		1	
C9	CAP, CER, 0.0012 UF +/-10%, 500V	106732	71590	CF122		2	
C10	CAP, MICA, 100 PF +/-5%, 500V	148494	72136	DM15F101J		2	
C22	CAP, CER, 0.22 UF +/-20%, 50V	309849	71590	CW30C224K		1	
C23	CAP, CER, 0.0012 UF +/-10%, 500V	106732	71590	CF122			REF
C30	CAP, POLYPRPLN, 0.22 UF +/-10%, 50V	423410	89536	423210		1	
C31	CAP, TA, 68 UF +/-10%, 15V	182824	56289	150D686X9015R2		1	
C36	CAP, TA, 39 UF +/-20%, 20V	358234	56289	196D396X0020PE4		3	
C37	CAP, TA, 39UF +/-20%, 20V	358234	56289	196D396X0020PE4			REF
C38	CAP, POLYPRPLN, 0.033 UF +/-10%, 50V	424218	89536	424218		1	
C41	CAP, TA, 10 UF +/-20%, 20V	330662	56289	196D106X0020KA1		6	
C42	CAP, MICA, 33 PF +/-5%, 500V	160317	72136	DM15E330J			REF
C43	CAP, CER, 0.01 UF +/-20%, 100V	149153	56289	C023B101F103M		1	
C46	CAP, TA, 39 UF +/-20%, 20V	358234	56289	196D396X0020PE4			REF
C47	CAP, POLYCARB, 0.68 UF +/-10%, 50V	284695	84411	X463UW6849.50W		4	
C49	CAP, TA, 1 UF +/-20%, 35V	161919	56289	196D105X0035JA1		2	
C50	CAP, TA, 1 UF +/-20%, 35V	161919	56289	196D105X0035JA1			REF
C51	CAP, MICA, 33 PF +/-5%, 500V	160317	72136	DM15E330J			REF
C52	CAP, POLYCARB, 0.68 UF +/-10%, 50V	284695	84411	X463UW6849.50W			REF
C53	CAP, POLYCARB, 0.68 UF +/-10%, 50V	284695	84411	X463UW6849.50W			REF
C65	CAP, MICA, 250 PF +/-5%, 500V	148478	72136	DM15F151J		2	
C66	CAP, MICA, 250 PF +/-5%, 500V	148478	72136	DM15F151J			REF
C67	CAP, MICA, 100 PF +/-5%, 500V	148494	72136	DM15F101J			REF
C70	CAP, MICA, 2000 PF +/-5%, 500V	321158	72136	DM19F202J		1	
C71	CAP, POLYCARB, 0.68 UF +/-10%, 50V	284695	84411	X463UW6849.50W			REF
C72	CAP, FXD, MTL. POLY, 1.0 UF +/-10%, 100V	313262	84411	X463UW10591		2	
C73	CAP, POLYCARB, 5.0 UF +/-10%, 5V	313254	84411	X463UW5059.50		1	
C74	CAP, POLYPRPLN, 0.1 UF +/-10%, 50V	413310	89536	413310		1	
C76	CAP, FXD, MTL. POLY, 1.0 UF +/-10%, 100V	313262	84411	X463UW10591			REF
C100	CAP, TA, 10 UF +/-20%, 20V	330662	56289	196D106X0020KA1			REF
C101	CAP, TA, 10 UF +/-20%, 20V	330662	56289	196D106X0020KA1			REF
C102	CAP, TA, 10 UF +/-20%, 20V	330662	56289	196D106X0020KA1			REF
C103	CAP, TA, 10 UF +/-20%, 20V	330662	56289	196D106X0020KA1			REF
C104	CAP, TA, 10 UF +/-20%, 20V	330662	56289	196D106X0020KA1			REF
C110	CAP, MINI, CER, 100 PF +/-2%, 100V	369173	72982	8141-A100-COG-101G		6	
C111	CAP, MINI, CER, 100 PF +/-2%, 100V	369173	72982	8141-A100-COG-101G			REF
C112	CAP, MINI, CER, 100 PF +/-2%, 100V	369173	72982	8141-A100-COG-101G			REF
C113	CAP, MINI, CER, 100 PF +/-2%, 100V	369173	72982	8141-A100-COG-101G			REF
C114	CAP, MINI, CER, 100 PF +/-2%, 100V	369173	72982	8141-A100-COG-101G			REF
C115	CAP, MINI, CER, 100 PF +/-2%, 100V	369173	72982	8141-A100-COG-101G			REF

Table 5-20. A14 Analog Control PCB Assembly (cont)

REF DES	DESCRIPTION	FLUKE STOCK NO.	MFG SPLY CODE	MFG PART NO. OR TYPE	TOT QTY	REC QTY	NO TE
CR2	DIODE, SI, HI-SPEED SWITCHING	203323	07910	IN4448	6		2
CR4	DIODE, SI, HI-SPEED SWITCHING	203323	07910	IN4448	REF		
CR5	DIODE, SI, HI-SPEED SWITCHING	203323	07910	IN4448	REF		
CR37	DIODE, FET, CURRENT REG	429373	07910	TCR5309	1		1
CR46	DIODE, SI, LO-CAP, LO-LEAK	348177	07236	FD7223	2		1
CR47	DIODE, SI, LO-CAP, LO-LEAK	348177	07236	FD7223	REF		
CR60	DIODE, FET, CURRENT REG	334839	07910	TCR5297	2		1
CR61	DIODE, FET, CURRENT REG	334839	07910	TCR5297	REF		
CR70	DIODE, SILICON, 75 MA, 90DIV	260554	07910	CD55105	1		1
CR81	DIODE, SI, RECTIFIER	347559	05277	IN5400	2		1
CR82	DIODE, SI, RECTIFIER	347559	05277	IN5400	REF		
CR92	DIODE, SI, HI-SPEED SWITCHING	203323	07910	IN4448	REF		
CR93	DIODE, SI, HI-SPEED SWITCHING	203323	07910	IN4448	REF		
CR95	DIODE, SI, HI-SPEED SWITCHING	203323	07910	IN4448	REF		
E1	TERMINAL, FEED-THRU	281865	12615	SL-841-777	1		
H1	NUT, HEX, 4-40NC2B	184044	89536	184044	2		
H2	SCREW, PHP, SEMS, 4-40X1/4	129890	73734	19022	2		
H3	LOCKWASHER, #4	110403	73734	99402	2		
K1	RELAY, DRY REED, SPST	404590	71707	CR4503	3		
K2	RELAY, DRY REED, DPST	340638	95348	F81-5064-1	2		
K3	RELAY, DRY REED, DPST	340638	95348	F81-5064-1	REF		
K4	RELAY, DRY REED, SPST	404590	71707	CR4503	REF		
K5	RELAY, DRY REED, SPST	404590	71707	CR4503	REF		
L37	CHOKE, 6-TURN	320911	89536	320911	5		
L45	FERRITE, TUBE, CHOKE CORE	321182	02114	56-590-65-4B	2		
L46	FERRITE, TUBE, CHOKE CORE	321182	02114	56-590-65-4B	REF		
L50	CHOKE, 6-TURN	320911	89536	320911	REF		
L100	CHOKE, 6-TURN	320911	89536	320911	REF		
L101	CHOKE, 6-TURN	320911	89536	320911	REF		
L102	CHOKE, 6 TURN	320911	89536	320911	REF		
P53	CONNECTOR, COAX, PCB MTG	353243	98291	51-053-0000	2		
P54	CONNECTOR, COAX, PCB MTG	353243	98291	51-053-0000	REF		
Q1	XSTR, SI, NPN, S/SIG, 200MA	218396	04713	2N3904	5		1
Q2	XSTR, SI, PNP	195974	04713	2N3906	5		1
Q3	XSTR, SI, NPN, S/SIG, 200MA	218396	04713	2N3904	REF		
Q4	XSTR, SI, PNP	195974	04713	2N3906	REF		
Q5	XSTR, SI, PNP	195974	04713	2N3906	REF		
Q10	XSTR, FET, N-CHANNEL	370072	89536	370072	5		1
Q16	XSTR, SI, NPN, S/SIG, 200MA	218396	04713	2N3904	REF		
Q36	XSTR, FET N-CHANNEL	288324	89536	288324	1		1
Q44	XSTR, SI, PNP	195974	04713	2N3906	REF		
Q45	XSTR, SI, PNP	229898	04713	MPS6522	1		1
Q46	XSTR, SI, NPN	218081	04713	MPS6520	1		1
Q55	XSTR, SI, NPN, S/SIG, 200MA	218396	04713	2N3904	REF		
Q61	XSTR, SI, NPN	329698	04713	2N2484	2		1
Q62	XSTR, FET, N-CHANNEL	370072	89536	370072	REF		
Q63	XSTR, FET, N-CHANNEL	370072	89536	370072	REF		
Q65	XSTR, DUAL, SI, NPN	295717	24355	AD811-00/17	1		1
Q68	XSTR, DUAL, SI, NPN	284075	24355	AD20/19	1		1
Q69	XSTR, SI, NPN	329698	04713	2N2484	REF		

Table 5-20. A14 Analog Control PCB Assembly (cont)

REF DES	DESCRIPTION	FLUKE STOCK NO.	MFG SPLY CODE	MFG PART NO. OR TYPE	TOT QTY	REC QTY	NO TE
Q73	XSTR, FET, N-CHANNEL	370072	89536	370072	REF		
Q74	XSTR, FET, N-CHANNEL	370072	89536	370072	REF		
Q81	XSTR, SI, PWR PNP	325753	03508	D45C5	1	1	
Q82	XSTR, SI, NPN	325761	09214	D44C5	1	1	
Q85	XSTR, SI, PNP	195974	04713	2N3906	REF		
Q86	XSTR, SI, NPN, S/SIG, 200MA	218396	04713	2N3904	REF		
Q88	XSTR, FET, N-CHANNEL	261578	89536	261578	2	1	
Q89	XSTR, FET, N-CHANNEL	261578	89536	261578	REF		
Q93	XSTR, SI, PNP	226290	04713	MPS3640	1	1	
R1	RES, DEP. CAR, 1.3K +/-5%, 1/4W	441394	80031	CR251-4-5P1K3T	2		
R2	RES, DEP. CAR, 470 +/-5%, 1/4W	343434	80031	CR251-4-5P470ET	3		
R3	RES, DEP. CAR, 470 +/-5%, 1/4W	343434	80031	CR251-4-5P470ET	REF		
R4	RES, DEP. CAR, 1.3K +/-5%, 1/4W	441394	80031	CR251-4-5P1K3T	REF		
R5	RES, MTL. FILM, 4.22K +/-1%, 1/8W	168245	91637	CMF554221F	1		
R6	RES, MTL. FILM, 1.27K +/-1%, 1/8W	267369	91637	CMF551271F	2		
R7	RES, MTL. FILM, 10K +/-1%, 1/8W	168260	91637	CMF551002F	2		
R8	RES, MTL. FILM, 4.99K +/-1%, 1/8W	168252	91637	CMF554991F	1		
R9	REF AMP SET (R9, R10, U10)	425959	89536	425959	1		
R10	REF AMP SET (PART OF R9 SET)				REF		
R11	RES, VAR, CERMET, 100 +/-20%, 1/2W	267823	71450	190PC101B	2	1	
R12	RES, MTL. FILM, 1.27K +/-1%, 1/8W	267369	91637	CMF551271F	REF		
R13	RES, SELECTED						1
R14	RES, SELECTED						1
R15	RES, MTL. FILM, 2.26K +/-1%, 1/8W	328294	91637	CMF552261F	1		
R16	RES, COMP, 220 +/-5%, 1/2W	186031	01121	EB2215	2		
R17	RES, REF SUPPLY SET (R17,R20)	346304	89536	346304	1	1	
R18	RES, MTL. FILM, 10 +/-1%, 1/8W	268789	91637	CMF55A100F	2		
R19	RES, MTL. FILM, 10 +/-1%, 1/8W	268789	91637	CMF55A100F	REF		
R20	RES, REF SUPPLY SET (R17,R20)	346304	89536	346304	REF		
R22	RESISTOR SET, FXD, WW, 10K	291690	89536	291690	1	1	
R23	RES, VAR, CERMET, 100 +/-20%, 1/2W	267823	71450	190PC101B	REF		
R24	RES, COMP, 2 +/-5%, 1/2W	218735	01121	EB20G5	1		
R25	RESISTOR SET, FXD, WW, 10K	291690	89536	291690	REF		
R26	RES, COMP, 220 +/-5%, 1/2W	186031	01121	EB2215	REF		
R30	RES, MTL. FILM, 26.7K +/-1%, 1/8W	245779	91637	CMF552672F	1		
R31	RES, MTL. FILM, 562 +/-0.1%, 1/8W	375519	91637	CMF555620B	2		
R32	RES, VAR, CERMET, 20 +/-20%, 1/2W	261180	71450	190PC200B	1	1	
R33	RESISTOR MATCHED SET (R33 & R36)	417709	89536	417709	1	1	
R34	RES, MTL. FILM, 562 +/-0.1%, 1/8W	375519	91637	CMF555620B	REF		
R35	RES, MTL. FILM, 22.1K +/-1%, 1/8W	235234	91637	CMF552212F	1		
R36	RESISTOR MATCHED SET (R33 & R36)	417709	89536	417709	REF		
R37	RES, DEP. CAR, 510 +/-5%, 1/4W	441600	80031	CR251-4-5P510ET	1		
R38	RES, MTL. FILM, 20K +/-1%, 1/8W	291872	91637	CMF552002F	1		
R39	RES, VAR, CERMET, 100K +/-20%, 1/2W	268581	71450	190PC104B	1	1	
R40	RES, MTL. FILM, 1M +/-1%, 1/8W	268797	91637	CMF551004F	1		
R41	RES, MTL. FILM, 100 +/-1%, 1/8W	168195	91637	CMF551000F	1		
R42	RES, MTL. FILM, 41.2K +/-1%, 1/8W	289538	91637	CMF554122F	1		
R43	RES, DEP. CAR, 1K +/-5%, 1/4W	343426	80031	CR251-4-5P1K7	1		
R44	RES, MTL. FILM, 215 +/-1%, 1/2W	150862	91637	CMF652150F	1		
R45	RES, MTL. FILM, 174 +/-1%, 1/8W	343913	91637	CMF551740F	1		

Table 5-20. A14 Analog Control PCB Assembly (cont)

REF DES	DESCRIPTION	FLUKE STOCK NO.	MFG SPLY CODE	MFG PART NO. OR TYPE	TOT QTY	REC QTY	N O T E
R46	RES, MTL. FILM, 499 +/-1%, 1/8W	168211	91637	CMF554990F	1		
R47	RES, MTL. FILM, 29.4K +/-1%, 1/8W	344473	91637	CMF55942F	4		
R48	RES, MTL. FILM, 3.48K +/-1%, 1/8W	260687	91637	CMF553481F	2		
R49	RES, MTL. FILM, 7.50K +/-1%, 1/8W	223529	91637	CMF557501F	1		
R50	RES, MTL. FILM, 3.48K +/-1%, 1/8W	260687	91637	CMF553481F	REF		
R51	RES, MTL. FILM, 6.49K +/-1%, 1/8W	294900	91637	CMF556491F	1		
R52	RES, MTL. FILM, 15.8K +/-1%, 1/8W	293688	91637	CMF551582F	1		
R53	RES, DEP. CAR, 750 +/-5%, 1/4W	441659	80031	CR251-4-5P750ET	1		
R54	RES, DEP. CAR, 2.2K +/-5%, 1/4W	343400	80031	CR251-4-5P2K2T	2		
R55	RES, DEP. CAR, 10K +/-5%, 1/4W	348839	80031	CR251-4-5P10KT	5		
R56	RES, DEP. CAR, 10K +/-5%, 1/4W	348839	80031	CR251-4-5P10KT	REF		
R60	RES, MTL. FILM, 309K +/-1%, 1/8W	235283	91637	CMF553093F	1		
R61	RES, MTL. FILM, 10K +/-1%, 1/8W	168260	91637	CMF551002F	REF		
R62	RES, DEP. CAR, 10K +/-5%, 1/4W	348839	80031	CR251-4-5P10KT	REF		
R63	RES, VAR, CERMET, 5K +/-20%, 1/2W	267872	71450	190PC502B	1	1	
R64	RES, SELECTED						1
R65	RESISTOR MATCHED SET (R65, R67)	290320	89536	290320	1		
R66	RES, SELECTED						1
R67	RESISTOR MATCHED SET (R65, R67)				REF		
R68	RES, MTL. FILM, 2.8M +/-1%, 1/2W	236703	91637	CMF652804F	1		
R69	RES, DEP. CAR, 10K +/-5%, 1/4W	348839	80031	CR251-4-5P10KT	REF		
R70	RES, MTL. FILM, 499K +/-1%, 1/8W	268813	91637	CMF554993F	1		
R71	RES, VAR, CERMET, 100K +/-10%, 1/2W	288308	89536	288308	1	1	
R72	RES, COMP, 100M +/-10%, 1/2W	190520	01121	EB1071	2		
R73	RES, COMP, 100M +/-10%, 1/2W	190520	01121	EB1071	REF		
R74	RES, MTL. FILM, 29.4K +/-1%, 1/8W	344473	91637	CMF55942F	REF		
R75	RES, DEP. CAR, 47K +/-5%, 1/4W	348896	80031	CR251-4-5P47KT	1		
R76	RES, MTL. FILM, 40.2K +/-1%, 1/8W	235333	91637	CMF554022F	1		
R77	RES, MTL. FILM, 29.4K +/-1%, 1/8W	344473	91637	CMF55942F	REF		
R78	RES, MTL. FILM, 29.4K +/-1%, 1/8W	344473	91637	CMF55942F	REF		
R79	RES, DEP. CAR, 100 +/-5%, 1/4W	348771	80031	CR241-4-5P100ET	1		
R80	RES, COMP, 1.3K +/-5%, 1/2W	109157	01121	EB1325	2		
R81	RES, DEP. CAR, 33 +/-5%, 1/4W	414524	80031	CR251-4-5P33ET	2		
R82	RES, DEP. CAR, 33 +/-5%, 1/4W	414524	80031	CR251-4-5P33ET	REF		
R83	RES, COMP, 1.3K +/-5%, 1/2W	109157	01121	EB1325	REF		
R84	RES, MTL. FILM, 1.37K +/-1%, 1/2W	148874	91637	CMF541371F	2		
R85	RES, DEP. CAR, 75 +/-5%, 1/4W	441642	80031	CR251-4-5P75ET	2		
R86	RES, DEP. CAR, 75 +/-5%, 1/4W	441642	80031	CR251-4-5P75ET	REF		
R87	RES, MTL. FILM, 1.37K +/-1%, 1/2W	148874	91637	CMF541371F	REF		
R88	RES, MTL. FILM, 2.15K +/-1%, 1/8W	293712	91637	CMF552151F	2		
R89	RES, MTL. FILM, 2.15K +/-1%, 1/8W	293712	91637	CMF552151F	REF		
R90	RES, DEP. CAR, 22K +/-5%, 1/4W	348870	80031	CR251-4-5P22KT	2		
R91	RES, DEP. CAR, 2.2K +/-5%, 1/4W	343400	80031	CR251-4-5P2K2T	REF		
R92	RES, DEP. CAR, 470 +/-5%, 1/4W	343434	80031	CR251-4-5P470ET	REF		
R93	RES, DEP. CAR, 22K +/-5%, 1/4W	348870	80031	CR251-4-5P22KT	REF		
R94	RES, DEP. CAR, 150 +/-5%, 1/4W	343442	80031	CR251-4-5P150ET	1		
R96	RES, DEP. CAR, 4.7K +/-5%, 1/4W	348821	80031	CR251-4-5P4K7T	1		
R100	RES, DEP. CAR, 10K +/-5%, 1/4W	348839	80031	CR251-4-5P10KT	REF		
U2	IC, OP AMP	284760	12040	LM308H	2	1	
U3	IC, OP AMP	225961	24355	AD3092	2	1	

Table 5-20. Analog Control PCB Assembly (cont)

REF DES	DESCRIPTION	FLUKE STOCK NO.	MFG SPLY CODE	MFG PART NO. OR TYPE	TOT QTY	REC QTY	NOTE
U10	REF AMP SET (PART OF R9 SET)				REF		
U37	IC, LIN OP AMP	329912	12040	LM318H	1	1	
U42	IC, OP AMP	225961	24355	AD3092	REF		
U51	IC, OP AMP	271502	12040	LM301A	1	1	
U61	IC, OP-AMP J-FET INPUT	357830	89536	357830	1	1	
U67	IC, OP AMP	284760	12040	LM308H	REF		
U75	OPTO-ISOLATOR ST PHOTO XSTR	380014	29083	MCT2	1	1	
U83	IC, LIN, DIFF COMPTR	352195	12040	LM311PA	2	1	
U84	IC, LIN, DIFF COMPTR	352195	12040	LM311PA	REF		
U92	IC, TTL, HEX INVERTER BUFFER/DRIVER	288605	01295	SN7416N	1	1	
U93	IC, TTL, LO-PWR, HEX/QUAD D-F-F	393207	01295	SN74LS174N	1	1	
U94	⊗ IC, C-MOS, HEX, CONVERTER, 16-PIN DIP	381848	02735	CD4049AE	1	1	
U95	⊗ IC, C-MOS, TRI-STATE, HEX, NON/IN BUFF	407759	12040	MM80C97N	1	1	
U96	⊗ IC, C-MOS, DUAL "D" TYPE, F/F	418830	12040	MM74C74	1	1	
U97	⊗ IC, C-MOS, TRIPLE, 3-INPUT NAND GATE	418244	12040	MM74C10N	1	1	
U98	IC, TTL, LO-PWR, HEX, QUAD "D" TYPE, F/F	393215	01295	SN74LS175N	1	1	
U99	IC, TTL, QUAD, 2-INPUT, POS NAND GATES	292953	01295	SN7400N	1	1	
U100	ISOLATOR, HI-SPEED, OPTICALLY COUPLED	354746	28480	5082-4350	1	1	
VR60	DIODE, ZENER 3.9V	113316	07910	1N748	1	1	
VR61	DIODE, ZENER, 6.2V	325811	07910	1N753A	1	1	
VR62	DIODE, ZENER, 5%, 12.0V	203547	07910	1N759A	2	1	
VR63	DIODE, ZENER, 5%, 12.0V	203547	07910	1N759A	REF		
WT1	CABLE, TIE, SELFLOCKING	172080	06383	SST-1M	4		

1 SEE SEC. 4, FACTORY SELECTED COMPONENT REPLACEMENT

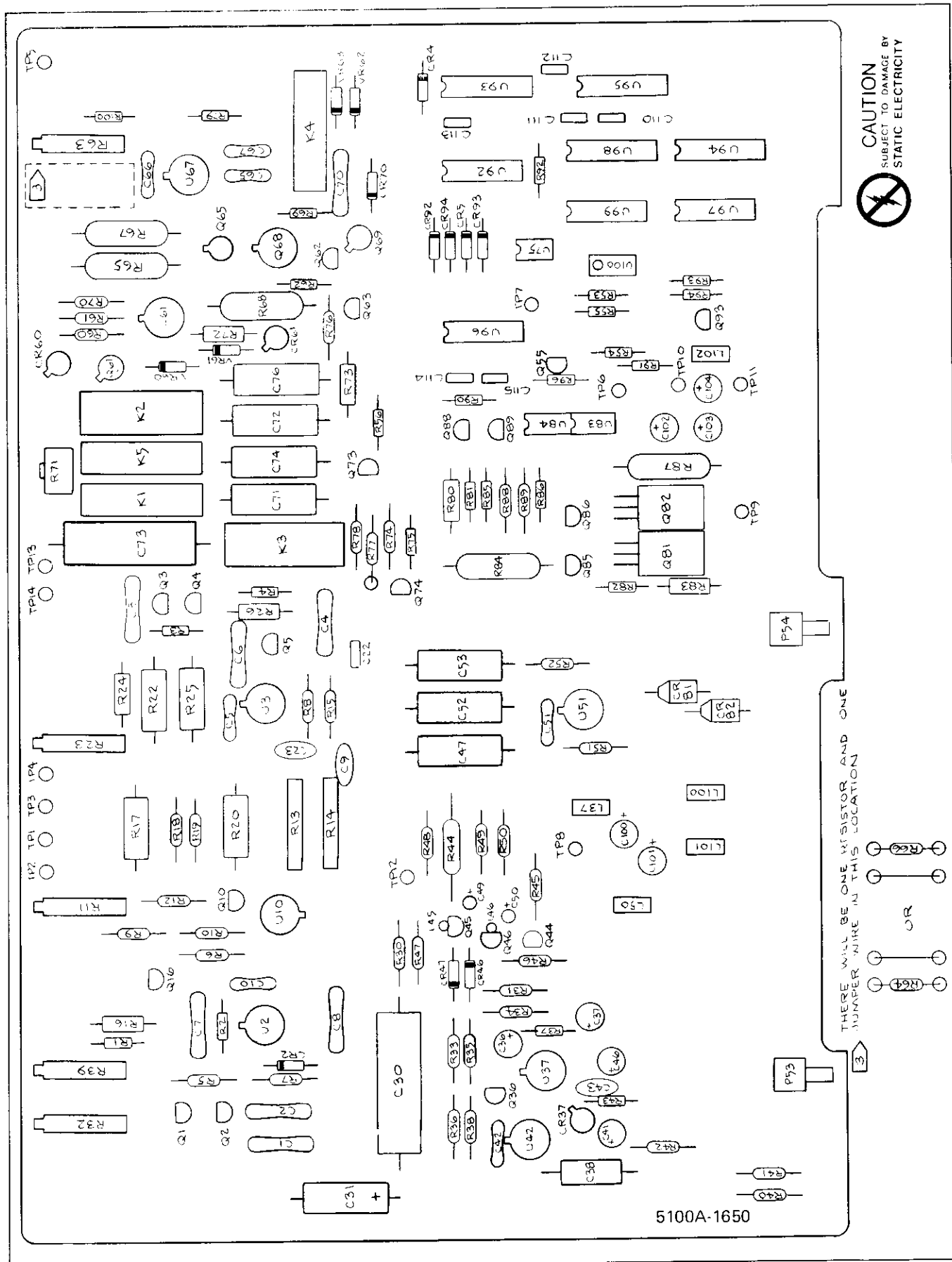

Figure 5-15. A14 Analog Control PCB Assembly

Table 5-21. A15 Digital-to-Analog Converter PCB Assembly

REF DES	DESCRIPTION	FLUKE STOCK NO.	MFG SPLY CODE	MFG PART NO. OR TYPE	TOT QTY	REC QTY	NOTE
A15	⊗ DIGITAL-TO-ANALOG CONVERTER PCB ASSEMBLY FIGURE 5-16 (5100A-4060T)	458422	89536	458422		REF	
C1	CAP, TA, 10 UF +/-20%, 20V	330662	56289	196D106X0020KA1	8		
C2	CAP, TA, 10 UF +/-20%, 20V	330662	56289	196D106X0020KA1		REF	
C3	CAP, MIC, 47 PF +/-5%, 35V	148536	72136	DM15E470J	1		
C4	CAP, TA, 1 UF +/-20%, 35V	161919	56289	1966D105X0020JA1	2		
C5	CAP, CER, 0.22 UF +/-20%, 50V	309849	71590	CW30C224K	11		
C6	CAP, CER, 0.22 UF +/-20%, 50V	309849	71590	CW30C224K		REF	
C7	CAP, CER, 0.22 UF +/-20%, 50V	309849	71590	CW30C224K		REF	
C8	CAP, TA, 10 UF +/-20%, 20V	330662	56289	196D106X0020KA1		REF	
C9	CAP, TA, 10 UF +/-20%, 20V	330662	56289	196D106X0020KA1		REF	
C10	CAP, CER, 0.22 UF +/-20%, 50V	309849	71590	CW30C224K		REF	
C11	CAP, POLYCAR, 0.68 UF +/-10%, 50V	284695	84411	X463UW6849.50W	4		
C12	CAP, CER, 0.01 UF +/-20%, 100V	149153	56289	C023B101F103M	3		
C13	CAP, CER, 0.05 UF +/-20%, 100V	149161	56289	55C23A1	1		
C14	CAP, POLYCAR, 0.68 UF +/-10%, 50V	284695	84411	X463UW6849.50W		REF	
C15	CAP, POLYCAR, 0.68 UF +/-10%, 50V	284695	84411	X463UW6849.50W		REF	
C16	CAP, MICA, 33 PF +/-5%, 500V	160317	72136	DM15E330J	1		
C17	CAP, POLYCAR, 0.68 UF +/-10%, 50V	284695	84411	X463UW6849.50W		REF	
C18	CAP, CER, 0.01 UF +/-20%, 100V	149153	56289	C023B101F103M		REF	
C19	CAP, TA, 1 UF +/-20%, 35V	161919	56289	1966D105X0020JA1		REF	
C20	CAP, TA, 6.8 UF +/-20%, 35V	363713	56289	1960685X0035KA1	1		
C21	CAP, TA, 10 UF +/-20%, 20V	330662	56289	196D106X0020KA1		REF	
C22	CAP, TA, 10 UF +/-20%, 20V	330662	56289	196D106X0020KA1		REF	
C23	CAP, CER, 0.01 UF +/-20%, 100V	149153	56289	C023B101F103M		REF	
C24	CAP, CER, 0.22 UF +/-20%, 50V	309849	71590	CW30C224K		REF	
C26	CAP, TA, 10 UF +/-20%, 20V	330662	56289	196D106X0020KA1		REF	
C27	CAP, TA, 10 UF +/-20%, 20V	330662	56289	196D106X0020KA1		REF	
C28	CAP, CER, 0.22 UF +/-20%, 50V	309849	71590	CW30C224K		REF	
C29	CAP, CER, 0.22 UF +/-20%, 50V	309849	71590	CW30C224K		REF	
C31	CAP, CER, 100 PF +/-2%, 100V	369173	72982	8141-A100-COG-101G	12		
C32	CAP, CER, 100 PF +/-2%, 100V	369173	72982	8141-A100-COG-101G		REF	
C33	CAP, CER, 100 PF +/-2%, 100V	369173	72982	8141-A100-COG-101G		REF	
C34	CAP, CER, 100 PF +/-2%, 100V	369173	72982	8141-A100-COG-101G		REF	
C35	CAP, CER, 100 PF +/-2%, 100V	369173	72982	8141-A100-COG-101G		REF	
C36	CAP, CER, 100 PF +/-2%, 100V	369173	72982	8141-A100-COG-101G		REF	
C37	CAP, CER, 100 PF +/-2%, 100V	369173	72982	8141-A100-COG-101G		REF	
C38	CAP, CER, 100 PF +/-2%, 100V	369173	72982	8141-A100-COG-101G		REF	
C39	CAP, CER, 100 PF +/-2%, 100V	369173	72982	8141-A100-COG-101G		REF	
C40	CAP, CER, 100 PF +/-2%, 100V	369173	72982	8141-A100-COG-101G		REF	
C41	CAP, CER, 100 PF +/-2%, 100V	369173	72982	8141-A100-COG-101G		REF	
C42	CAP, CER, 100 PF +/-2%, 100V	369173	72982	8141-A100-COG-101G		REF	
C43	CAP, CER, 0.22 UF +/-20%, 50V	309849	71590	CW30C224K		REF	
C44	CAP, CER, 0.22 UF +/-20%, 50V	309849	71590	CW30C224K		REF	
C45	CAP, CER, 0.22 UF +/-20%, 50V	309849	71590	CW30C224K		REF	
C46	CAP, CER, 0.22 UF +/-20%, 50V	309849	71590	CW30C224K		REF	
CR1	DIODE, SI, HI-SPEED SWITCHING	203323	07910	IN4448	9		2
CR2	DIODE, SI, HI-SPEED SWITCHING	203323	07910	IN4448		REF	
CR3	DIODE, SI, HI-SPEED SWITCHING	203323	07910	IN4448		REF	

Table 5-21. A15 Digital-to-Analog Converter PCB Assembly (cont)

REF DES	DESCRIPTION	FLUKE STOCK NO.	MFG SPLY CODE	MFG PART NO. OR TYPE	TOT QTY	REC QTY	N O T E
CR4	DIODE, SI, RECTIFIER	116111	05277	1N4817	1	1	
CR5	DIODE, FET, CURRENT LIMITER	334714	07910	TCR5315	2	1	
CR6	DIODE, SI, HI-SPEED SWITCHING	203323	07910	IN4448	REF		
CR7	DIODE, FET, CURRENT LIMITER	334714	07910	TCR5315	REF		
CR9	DIODE, SI, HI-SPEED SWITCHING	203323	07910	IN4448	REF		
CR10	DIODE, SI, HI-SPEED SWITCHING	203323	07910	IN4448	REF		
CR11	DIODE, SI, HI-SPEED SWITCHING	203323	07910	IN4448	REF		
CR12	DIODE, SI, HI-SPEED SWITCHING	203323	07910	IN4448	REF		
CR13	DIODE, SI, HI-SPEED SWITCHING	203323	07910	IN4448	REF		
E1	TERMINAL, FEED-THRU	281865	12615	SL-841-777	3		
H1	SCREW, SEMS, 4-40 X 1/4	185918	89536	185918	1		
H2	NUT, HEX	184044	73734	8033NP	1		
K1	RELAY, DRY REED, DPST	340638	71482	MRB2A05	2		
K2	RELAY, DRY REED, DPST	340638	71482	MRB2A05	REF		
K3	RELAY, DRY REED, SPST	424408	89536	424408	1		
L1	CHOKE, 3-TURN	452888	89536	452888	1		
L2	CHOKE, 6-TURN	320911	89536	320911	3		
L3	CHOKE, 6-TURN	320911	89536	320911	REF		
L4	CHOKE, 6-TURN	320911	89536	320911	REF		
P63	CONN, COAX, SNAP-ON RECPT, PCB MOUNT	353243	98291	51-053-0000	1		
Q1	XSTR, SI, PNP	226290	04713	MPS3640	1	1	
Q2	XSTR, SET (Q2, Q4, Q6-Q9)	418657	89536	418657	1	1	
Q3	XSTR, FET, N-CHANNEL	261578	89536	261578	2	1	
Q4	XSTR (PART OF Q2 SET)				REF		
Q5	XSTR, FET, N-CHANNEL	261578	89536	261578	REF		
Q6	XSTR, MATCHED SET	418657	89536	418657	REF		
Q7	XSTR (PART OF Q2 SET)				REF		
Q8	XSTR (PART OF Q2 SET)				REF		
Q9	XSTR (PART OF Q2 SET)				REF		
Q10	XSR, SI, NPN	159855	07910	CS23030	6		
Q11	XSR, SI, NPN	159855	07910	CS23030	REF		
Q12	XSR, SI, NPN	159855	07910	CS23030	REF		
Q13	XSR, SI, NPN	159855	07910	CS23030	REF		
Q14	XSR, SI, NPN	159855	07910	CS23030	REF		
Q15	XSR, SI, NPN	159855	07910	CS23030	REF		
R1	RES, DEP. CAR, 1K +/-5%, 1/4W	343426	80031	CR251-4-5P1KT	10		
R2	RES, DEP. CAR, 4.7K +/-5%, 1/4W	348821	80031	CR251-4-5P4K7T	4		
R3	RES, DEP. CAR, 330 +/-5%, 1/4W	368720	80031	CR251-4-5P330ET	7		
R4	RES, DEP. CAR, 330 +/-5%, 1/4W	368720	80031	CR251-4-5P330ET	REF		
R5	RES, DEP. CAR, 330 +/-5%, 1/4W	368720	80031	CR251-4-5P330ET	REF		
R6	RES, DEP. CAR, 330 +/-5%, 1/4W	368720	80031	CR251-4-5P330ET	REF		
R7	RES, DEP. CAR, 470 +/-5%, 1/4W	343434	80031	CR251-4-5P470ET	3		
R8	RES, DEP. CAR, 1K +/-5%, 1/4W	343426	80031	CR251-4-5P1KT	REF		
R9	RES, DEP. CAR, 330 +/-5%, 1/4W	368720	80031	CR251-4-5P330ET	REF		
R10	RES, DEP. CAR, 1K +/-5%, 1/4W	343426	80031	CR251-4-5P1KT	REF		
R11	RES, DEP. CAR, 1K +/-5%, 1/4W	343426	80031	CR251-4-5P1KT	REF		
R12	RES, DEP. CAR, 1K +/-5%, 1/4W	343426	80031	CR251-4-5P1KT	REF		
R14	RES, DEP. CAR, 22K +/-5%, 1/4W	348870	80031	CR251-4-5P22KT	1		
R15	RES, DEP. CAR, 150 +/-5%, 1/4W	343442	80031	CR251-4-5P150ET	2		
R16	RES, DEP. CAR, 1K +/-5%, 1/4W	343426	80031	CR251-4-5P1KT	REF		

Table 5-21. A15 Digital-to-Analog Converter PCB Assembly (cont)

REF DES	DESCRIPTION	FLUKE STOCK NO.	MFG SPLY CODE	MFG PART NO. OR TYPE	TOT QTY	REC QTY	N O T E
R17	RES, DEP. CAR, 470 +/-5%, 1/4W	343434	80031	CR251-4-5P470ET	REF		
R19	RES, DEP. CAR, 220 +/-5%, 1/4W	342626	80031	CR251-4-5P220ET	2		
R20	RES, DEP. CAR, 220 +/-5%, 1/4W	342626	80031	CR251-4-5P220ET	REF		
R21	RES, DEP. CAR, 360 +/-5%, 1/4W	352286	80031	CR251-4-5P360ET	2		
R22	RES, DEP. CAR, 330 +/-5%, 1/4W	368720	80031	CR251-4-5P330ET	REF		
R23	RES, DEP. CAR, 330 +/-5%, 1/4W	368720	80031	CR251-4-5P330ET	REF		
R24	RES, DEP. CAR, 33 +/-5%, 1/4W	414524	80031	CR251-4-5P33ET	1		
R25	RES, DEP. CAR, 1K +/-5%, 1/4W	343426	80031	CR251-4-5PIKT	REF		
R26	RES, DEP. CAR, 360 +/-5%, 1/4W	352286	80031	CR251-4-5P360ET	REF		
R27	RES, DEP. CAR, 560 +/-5%, 1/4W	385948	80031	CR251-4-5P560ET	2		
R28	RES, DEP. CAR, 560 +/-5%, 1/4W	385948	80031	CR251-4-5P560ET	REF		
R29	RES, DEP. CAR, 3.3K +/-5%, 1/4W	348813	80031	CR251-4-5P3K3T	2		
R30	RES, DEP. CAR, 2.7K +/-5%, 1/4W	386490	80031	CR251-4-5P2K7T	2		
R31	RES, DEP. CAR, 3.3K +/-5%, 1/4W	348813	80031	CR251-4-5P3K3T	REF		
R32	RES, DEP. CAR, 2.7K +/-5%, 1/4W	386490	80031	CR251-4-5P2K7T	REF		
R33	RES, DEP. CAR, 4.7K +/-5%, 1/4W	348821	80031	CR251-4-5P4K7T	REF		
R34	RES, DEP. CAR, 10K +/-5%, 1/4W	348839	80031	CR251-4-5P10KT	1		
R35	RES, MATCHED, 100K, 1/4W	299222	89536	299222	1	1	
R36	RES, MTL. FILM, 3.24M +/-1%, 1/2W	381525	91637	CMF653244F	2		
R37	RES, MTL. FILM, 3.24M +/-1%, 1/2W	381525	91637	CMF653244F	REF		
R38	RES, MTL. FILM, 301 +/-1%, 1/8W	267740	91637	CMF553010F	1		
R40	RESISTOR MATCHED SET, 24.910K	421180	89536	421180	1	1	
R41	RES, MTL. FILM, 75 +/-1%, 1/8W	306027	91637	CMF55A750F	1		
R42	RES, VAR, CERMET, 20 +/-20%, 1/2W	261180	11236	190PC200B	1	1	
R43	RES, MTL. FILM, 2K +/-1%, 1/8W	291872	91637	CMF552001F	3		
R44	RES, MTL. FILM, 2K +/-1%, 1/8W	291872	91637	CMF552001F	REF		
R45	RES, MTL. FILM, 2K +/-1%, 1/8W	291872	91637	CMF552001F	REF		
R46	RES, DEP. CAR, 2.2K +/-5%, 1/4W	343400	80031	CR251-4-5P2K2T	1		
R47	RES, DEP. CAR, 27K +/-5%, 1/4W	441501	80031	CR251-4-5P27KT	2		
R48	RES, DEP. CAR, 27K +/-5%, 1/4W	441501	80031	CR251-4-5P27KT	REF		
R49	RES, DEP. CAR, 1K +/-5%, 1/4W	343426	80031	CR251-4-5PIKT	REF		
R50	RES, DEP. CAR, 470 +/-5%, 1/4W	343434	80031	CR251-4-5P470ET	REF		
R51	RES, DEP. CAR, 150 +/-5%, 1/4W	343442	80031	CR251-4-5P150ET	REF		
R52	RES, DEP. CAR, 4.7K +/-5%, 1/4W	348821	80031	CR251-4-5P4K7T	REF		
R53	RES, DEP. CAR, 4.7K +/-5%, 1/4W	348821	80031	CR251-4-5P4K7T	REF		
R60	RES, DEP. CAR, 1K +/-5%, 1/4W	343426	80031	CR251-4-5PIKT	REF		
R61	RES, DEP. CAR, 1K +/-5%, 1/4W	343426	80031	CR251-4-5PIKT	REF		
T1	XFMR, PULSE	420901	89536	420901	1		
U2	⊗ IC, C-MOS, HEX, BUFFER/INVERTERS	381830	02735	CD4050AE	3	1	
U3	⊗ IC, C-MOS, HEX, BUFFER/INVERTERS	381830	02735	CD4050AE	REF		
U4	IC, TTL, DECADE COUNTERS	414227	01295	SN74LS162N	5	1	
U5	IC, TTL, 2-INPUT, EXCLUSIVE OR GATES	418277	01295	SN74136N	6	2	
U6	IC, TTL, HEX, QUAD, "D" TYPE, F/F	393215	01295	SN74LS175N	6	2	
U7	⊗ IC, C-MOS, HEX, BUFFER/INVERTERS	381830	02735	CD4050AE	REF		
U8	⊗ IC, C-MOS, NAND GATES	375147	02735	CD4023AE	1	1	
U9	IC, TTL, DECADE COUNTERS	414227	01295	SN74LS162N	REF		
U10	IC, TTL, 2-INPUT, EXCLUSIVE OR GATES	418277	01295	SN74136N	REF		
U11	IC, TTL, HEX, QUAD, "D" TYPE, F/F	393215	01295	SN74LS175N	REF		
U12	IC, TTL, DECADE COUNTERS	414227	01295	SN74LS162N	REF		
U13	IC, TTL, 2-INPUT, EXCLUSIVE OR GATES	418277	01295	SN74136N	REF		

Table B 2.1. A 15 Digital-to-Analog Converter PCB Assembly (cont)

REF DES	DESCRIPTION	FLUKE STOCK NO.	MFG SPLY CODE	MFG PART NO. OR TYPE	TOT QTY	REC QTY	N O T E
U14	IC, TTL, HEX, QUAD, "D" TYPE, F/F	393215	01295	SN74LS175N	REF		
U15	IC, TTL, DUAL, "D" TYPE CLEAR AND PRESET	393124	01295	SN74LS74N	1	1	
U16	IC, TTL, HEX, INVERTER	292979	01295	SN7404N	1	1	
U17	IC, TTL, DUAL, J-K NEG/EDG/TRIE, F/F	393157	01295	SN74LS107N	1	1	
U18	IC, TTL, 2-INPUT, EXCLUSIVE OR GATES	418277	01295	SN74136N	REF		
U19	IC, TTL, 2-INPUT, EXCLUSIVE OR GATES	418277	01295	SN74136N	REF		
U20	IC, TTL, HEX, QUAD, "D" TYPE, F/F	393215	01295	SN74LS175N	REF		
U22	IC, TTL, 2-INPUT, EXCLUSIVE OR GATES	418277	01295	SN74136N	REF		
U24	IC, TTL, DECADE COUNTERS	414227	01295	SN74LS162N	REF		
U25	IC, TTL, 2-INPUT, EXCLUSIVE OR GATES	418277	01295	SN74136N	REF		
U26	IC, TTL, HEX, QUAD, "D" TYPE, F/F	393215	01295	SN74LS175N	REF		
U27	IC, DUAL, 4-INPUT, POS AND GATE	408708	01295	SN74LS21N	1	1	
U28	IC, TTL, QUAD, 2-INPUT, POS, NAND GATE	393033	01295	SN74LS00N	1	1	
U29	IC, TTL, DUAL, J-K MASTER SLAVE, F/F	369694	01295	SN7476	1	1	
U30	IC, TTL, QUAD, 2-INPUT, POS NAND BUFFERS	310201	01295	SN7438N	2	1	
U31	⊗ IC, C-MOS, TRIPLE, 3-INPUT AND GATE	408807	02735	CD4073BE	1	1	
U32	OPTO-ISOLATOR, DUAL, DTL/TTL	418285	28480	5082-4364	1	1	
U33	IC, LIN, V, REG, SERIES	418251	04713	MC7924CP	1	1	
U34	IC, DUAL, "D" TYPE, EDGE TRIGGERED, F/F	418269	01295	SN74S74N	1	1	
U35	IC, TTL, HEX, QUAD, "D" TYPE, F/F	393215	01295	SN74LS175N	REF		
U36	IC, LIN, VOLTAGE FOLLOWER	288365	12040	LM310H	1	1	
U37	IC, TTL, QUAD, 2-INPUT, POS NAND BUFFERS	310201	01295	SN7438N	REF		
U38	INTEGRATED CIRCUIT	454330	89536	MCT6	1	1	
U39	IC, OP AMP	271502	12040	LM301A	1	1	
XY1	SOCKET, CRYSTAL	148668	91506	80001G10	1		
Y1	XSTAL, QUARTZ, 8MHZ	422519	89536	422519	1		

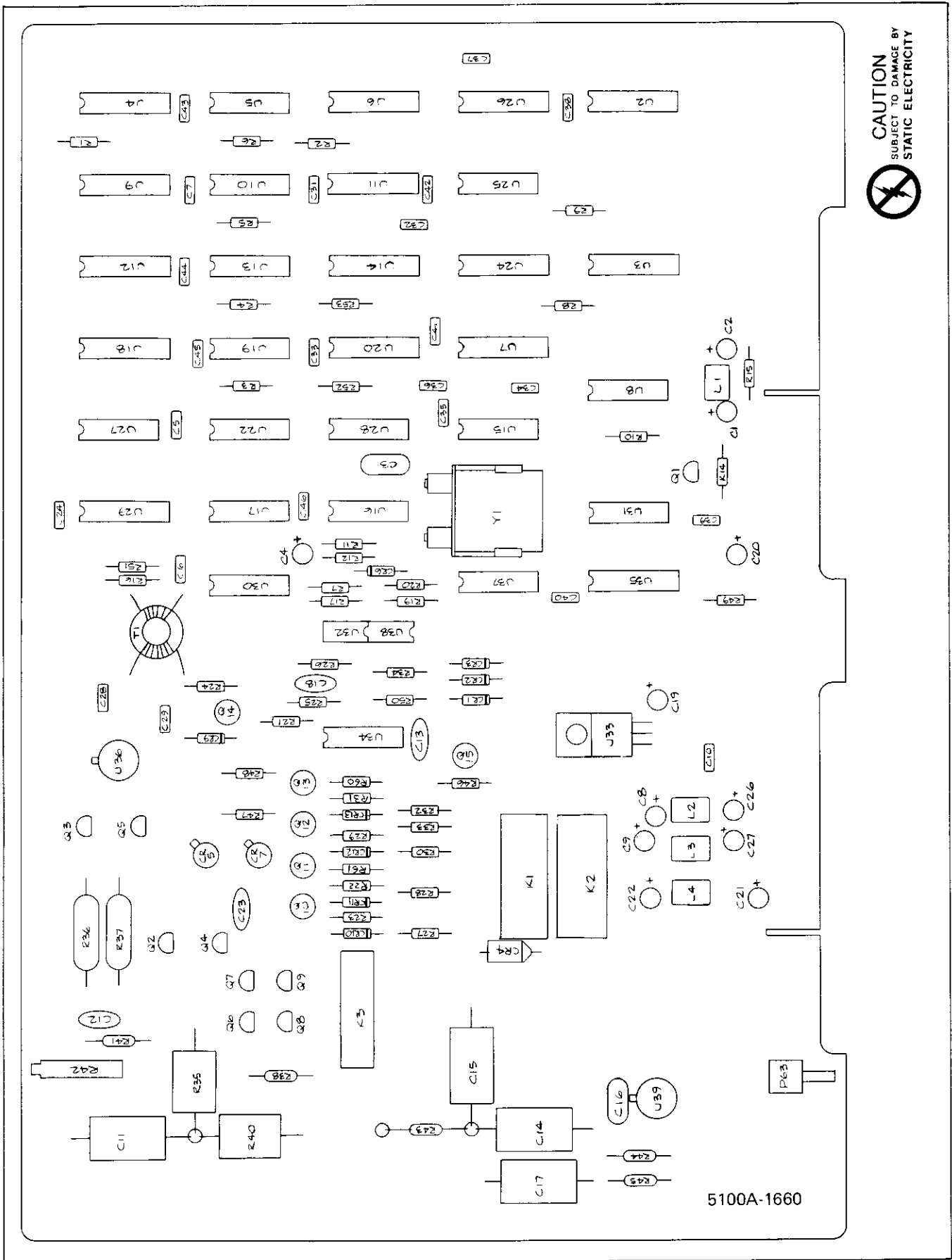

Figure 5-16. A15 Digital-to-Analog Converter PCB Assembly

Table 5-22. A16 Extended High Voltage PCB Assembly, Non-Environmental Case

REF DES	DESCRIPTION	FLUKE STOCK NO.	MFG SPLY CODE	MFG PART NO. OR TYPE	TOT QTY	REC QTY	NOTE
A16	EXTENDED HIGH VOLTAGE PCB ASSEMBLY FIGURE 5-17 (5100A-4071T) USED ON 5100B AND 5101B	510040	89536	510040		REF	
A16A1	HIGH VOLTAGE CONTROL PCB ASSEMBLY FIGURE 5-18A (5100A-4072)	ORDER	NEXT	HIGHER ASSEMBLY			
C1	CAP, TA, 10 UF +/-20%, 20V	330662	56289	196D106X0020KA1	6		
C2	CAP, TA, 10 UF +/-20%, 20V	330662	56289	196D106X0020KA1	REF		
C3	CAP, TA, 10 UF +/-20%, 20V	330662	56289	196D106X0020KA1	REF		
C4	CAP, TA, 10 UF +/-20%, 20V	330662	56289	196D106X0020KA1	REF		
C5	CAP, TA, 10 UF +/-20%, 20V	330662	56289	196D106X0020KA1	REF		
C6	CAP, TA, 10 UF +/-20%, 20V	330662	56289	196D106X0020KA1	REF		
C10	CAP, POLYSTR, 0.33 UF +/-20%, 2 KV	423301	89536	423301	2		
C11	CAP, POLYSTR, 0.33 UF +/-20%, 2 KV	423301	89536	423301	REF		
C12	CAP, CER, 0.05 UF +/-20%, 100V	149161	56289	55C23A1	2		
C13	CAP, CER, 0.05 UF +/-20%, 100V	149161	56289	55C23A1	REF		
C14	CAP, POLYCAR, 0.33 UF +/-10%, 400V	447623	73445	C280MCF/A330K	1		
CR8	DIODE, SI, FAST RECOVERY	418616	83003	VA20X	4	1	
CR9	DIODE, SI, FAST RECOVERY	418616	83003	VA20X	REF		
CR10	DIODE, SI, FAST RECOVERY	418616	83003	VA20X	REF		
CR11	DIODE, SI, FAST RECOVERY	418616	83003	VA20X	REF		
CR12	DIODE, SI, HI-SPEED SWITCHING	203323	07910	1N4448	2		
CR13	DIODE, SI, HI-SPEED SWITCHING	203323	07910	1N4448	REF		
H1	SCREW, PHP, 2-56 X 3/8	146803	73734	22204	1		
H2	SCREW, PHP, 4-40 X 1/4	129890	89536	129890	2		
H3	SCREW, PHP, 6-32 X 5/8	152181	89536	152181	6		
H4	SCREW, PHP, 8-32 X 3/8	114124	89536	114124	4		
H5	SCREW, PHP, SEMS, 6-32 X 1/4	178533	89536	178533	12		
H6	SPACER, HEX, THREADED	246868	89536	246868	4		
K1	RELAY, MERC, REED	357509	71707	UF-40066	4		
K2	RELAY, MERC, REED	357509	71707	UF-40066	REF		
K3	RELAY, MERC, DPST	447565	89536	447565	1		
K4	RELAY, TELE, TYPE DPDT	514240	26806	A2-420-12-203	2		
K5	RELAY, TELE, TYPE DPDT	514240	26806	A2-420-12-203	REF		
K6	RELAY, MERC, REED	357509	71707	UF-40066	REF		
K7	RELAY, MERC, REED	357509	71707	UF-40066	REF		
L1	CHOKE, 6-TURN	320911	89536	320911	3		
L2	CHOKE, 6-TURN	320911	89536	320911	REF		
L3	CHOKE, 6-TURN	320911	89536	320911	REF		
L4	INDUCTOR	363176	24759	MR-3900	1		
MP1	STRAP, RUBBER, MOUSETAIL	104794	98159	2829-115-3	5		
MP2	SPACER, #6	153155	89536	153155	6		
MP3	PLATE, SIDE	514802	89536	514802	1		
MP4	GUIDE, BRACKET	425140	89536	425140	2		
MP6	BRACKET, HIGH VOLTAGE CONNECTOR	426205	89536	426205	1		
MP7	RETAINER, RELAY	376459	77342	20C249	2		
MP8	MOUNTING BRACKET, BOTTOM	511212	89536	511212	1		
MP9	MOUNTING BRACKET, TOP	511204	89536	511204	1		

Table 5-22. A16 Extended High Voltage PCB Assembly, Non-Environmental Case (cont)

REF DES	DESCRIPTION	FLUKE STOCK NO.	MFG SPLY CODE	MFG PART NO. OR TYPE	TOT QTY	REC QTY	N O T E
P73	CONNECTOR, HIGH VOLTAGE, 2-CONTACT	442897	91637	G16P-AB	1		
R1	RES, COMP, 330K +/-5%, 1W	109777	01121	GB3345	3		
R2	RES, COMP, 330K +/-5%, 1W	109777	01121	GB3345		REF	
R3	RES, COMP, 330K +/-5%, 1W	109777	01121	GB3345		REF	
R4	RES, COMP, 2.7K +/-5%, 1W	296442	01121	GB2725	2		
R5	RES, COMP, 2.7K +/-5%, 1W	296442	01121	GB2725		REF	
R6	RES, COMP, 2.2K +/-10%, 1W	109843	01121	GB2221	1		
R7	RES, MTL. FILM, 7.15K +/-1%, 1/2W	186072	91637	CMF657151F	1		
R8	RES, MTL. FILM, 1.91K +/-1%, 1/2W	245621	91637	CMF651911F	1		
R9	RES, COMP, 390 +/-10%, 1W	109561	01121	GB3911	1		
RV1	VARIATOR, 150V +/-10%	474122	09214	V150MA2B	1		
T1	XFMR, EXT HIGH VOLTAGE	510057	89536	510057	1		
T2	XFMR, HI-FREQUENCY	432997	89536	432997	1		
TP1	TERMINAL, TEFLON FEED-THRU	281865	12615	SL-841-777	1		
U1	IC, LIN, OP AMP, MONOLITHIC, J-FET INPUT	429837	12040	LF356F	1		1
VR1	DIODE, ZENER, 9.1V	459917	12969	UZ8709	2		
VR2	DIODE, ZENER, 9.1V	459917	12969	UZ8709		REF	
W1	CABLE	418764	89536	418764	2		
W2	CABLE	418764	89536	418764		REF	
XK4	SOCKET, RELAY	376665	77342	27E501	2		
XK5	SOCKET, RELAY	376665	77342	27E501		REF	

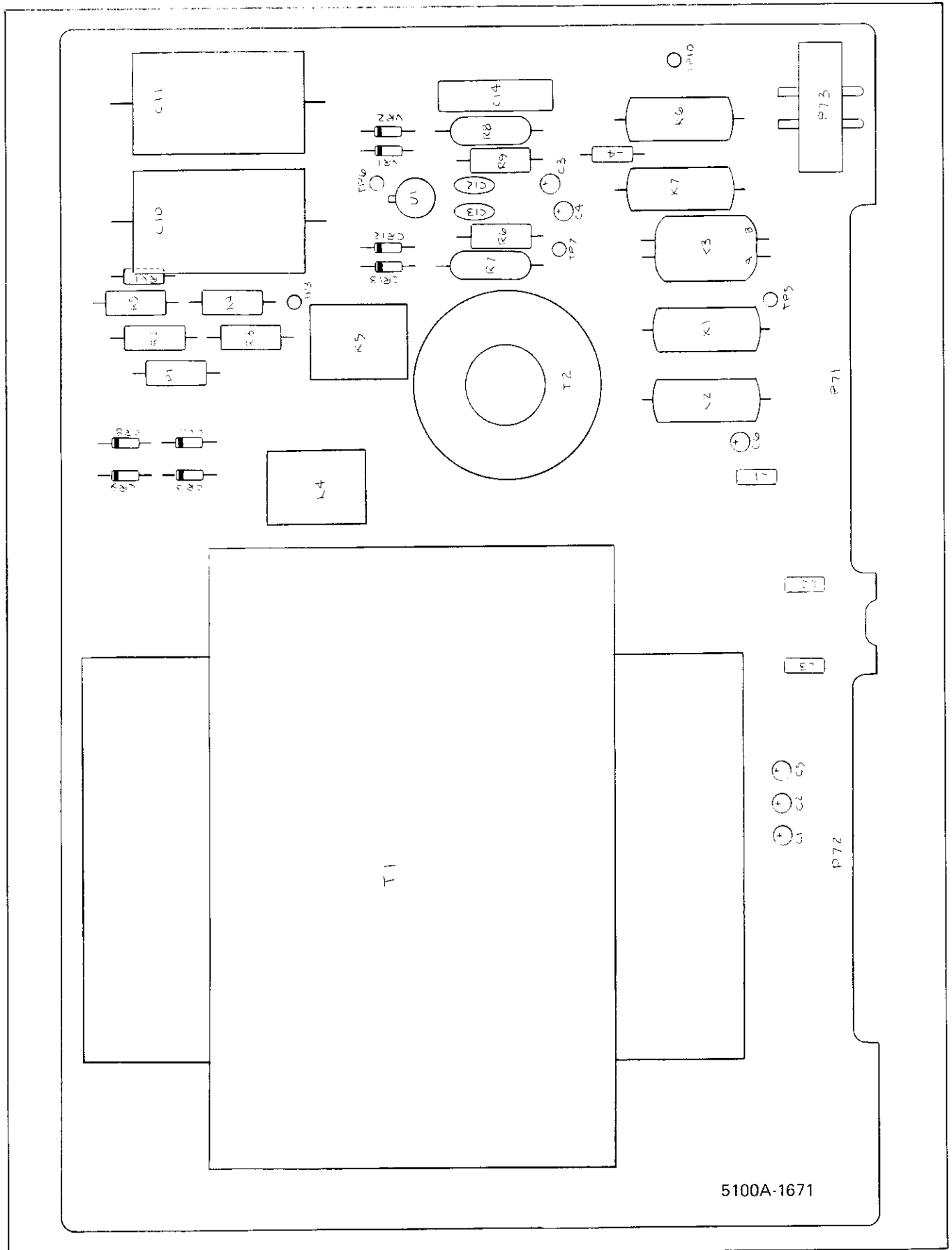

5100A-1671

Figure 5-17. A16 Extended High Voltage PCB Assembly, Non-Environmental Case

Table 5-23. A16 Extended High Voltage PCB Assembly, Environmental Case

REF DES	DESCRIPTION	FLUKE STOCK NO.	MFG SPLY CODE	MFG PART NO. OR TYPE	TOT QTY	REC QTY	NOTE
A16	EXTENDED HIGH VOLTAGE PCB ASSEMBLY FIGURE 5-18 (5102A-4071T) USED ON 5102B	514976	89536	514976		REF	
A16A1	HIGH VOLTAGE CONTROL PCB ASSEMBLY FIGURE 5-18A (5100A-4072)	ORDER	NEXT	HIGHER ASSEMBLY			
C1	CAP, TA, 10 UF +/-20%, 20V	330662	56289	196D106X0020KA1	6		
C2	CAP, TA, 10 UF +/-20%, 20V	330662	56289	196D106X0020KA1		REF	
C3	CAP, TA, 10 UF +/-20%, 20V	330662	56289	196D106X0020KA1		REF	
C4	CAP, TA, 10 UF +/-20%, 20V	330662	56289	196D106X0020KA1		REF	
C5	CAP, TA, 10 UF +/-20%, 20V	330662	56289	196D106X0020KA1		REF	
C6	CAP, TA, 10 UF +/-20%, 20V	330662	56289	196D106X0020KA1		REF	
C10	CAP, POLYSTR, 0.33 UF +/-20%, 2 KV	423301	89536	423301	2		
C11	CAP, POLYSTR, 0.33 UF +/-20%, 2 KV	423301	89536	423301		REF	
C12	CAP, CER, 0.05 UF +/-20%, 100V	149161	56289	55C23A1	2		
C13	CAP, CER, 0.05 UF +/-20%, 100V	149161	56289	55C23A1		REF	
C14	CAP, POLYCAR, 0.33 UF +/-10%, 400V	447623	73445	C280MCF/A330K	1		
CR8	DIODE, SI, FAST RECOVERY	418616	83003	VA20X	4		1
CR9	DIODE, SI, FAST RECOVERY	418616	83003	VA20X		REF	
CR10	DIODE, SI, FAST RECOVERY	418616	83003	VA20X		REF	
CR11	DIODE, SI, FAST RECOVERY	418616	83003	VA20X		REF	
CR12	DIODE, SI, HI-SPEED SWITCHING	203323	07910	1N4448	2		
CR13	DIODE, SI, HI-SPEED SWITCHING	203323	07910	1N4448		REF	
H1	SCREW, PHP, 2-56 X 3/8	146803	73734	22204	1		
H2	SCREW, PHP, 4-40 X 1/4	129890	89536	129890	2		
H3	SCREW, PHP, 6-32 X 5/8	152181	89536	152181	6		
H4	SCREW, PHP, 8-32 X 3/8	114124	89536	114124	4		
H5	SCREW, PHP, SEMS, 6-32 X 1/4	178533	89536	178533	12		
H6	SPACER, HEX, THREADED	246868	89536	246868	4		
K1	RELAY, SPST, DRY REED	446757	77342	R505-E2-Y1-5	2		
K2	RELAY, SPST, DRY REED	446757	77342	R505-E2-Y1-5		REF	
K3	RELAY, DPST, DRY REED	441931	89536	441931	1		
K4	RELAY, TELE, TYPE DPDT	514240	26806	A2-420-12-203	2		
K5	RELAY, TELE, TYPE DPDT	514240	26806	A2-420-12-203		REF	
K6	RELAY, SPST, DRY REED	441949	89536	441949	2		
K7	RELAY, SPST, DRY REED	441949	89536	441949		REF	
L1	CHOKE, 6-TURN	320911	89536	320911	3		
L2	CHOKE, 6-TURN	320911	89536	320911		REF	
L3	CHOKE, 6-TURN	320911	89536	320911		REF	
L4	INDUCTOR	363176	24759	MR-3900	1		
MP1	STRAP, RUBBER, MOUSETAIL	104794	98159	2829-115-3	5		
MP2	SPACER, #6	153155	89536	153155	6		
MP3	PLATE, SIDE	514802	89536	514802	1		
MP4	GUIDE, BRACKET	425140	89536	425140	2		
MP5	DECAL	508143	89536	508143	1		
MP6	BRACKET, HIGH VOLTAGE CONNECTOR	426205	89536	426205	1		
MP7	RETAINER, RELAY	376459	77342	20C249	2		
MP8	MOUNTING BRACKET, BOTTOM	511212	89536	511212	1		

Table 5-23. A16 Extended High Voltage PCB Assembly, Environmental Case (cont)

REF DES	DESCRIPTION	FLUKE STOCK NO.	MFG SPLY CODE	MFG PART NO. OR TYPE	TOT QTY	REC QTY	N O T E
MP9	MOUNTING BRACKET, TOP	511204	89536	511204	1		
P73	CONNECTOR, HIGH VOLTAGE, 2-CONTACT	442897	91637	G16P-AB	1		
R1	RES, COMP, 330K +/-5%, 1W	109777	01121	GB3345	3		
R2	RES, COMP, 330K +/-5%, 1W	109777	01121	GB3345	REF		
R3	RES, COMP, 330K +/-5%, 1W	109777	01121	GB3345	REF		
R4	RES, COMP, 2.7K +/-5%, 1W	296442	01121	GB2725	2		
R5	RES, COMP, 2.7K +/-5%, 1W	296442	01121	GB2725	REF		
R6	RES, COMP, 2.2K +/-10%, 1W	109843	01121	GB2221	1		
R7	RES, MTL. FILM, 7.15K +/-1%, 1/2W	186072	91637	CMF657151F	1		
R8	RES, MTL. FILM, 1.91K +/-1%, 1/2W	245621	91637	CMF651911F	1		
R9	RES, COMP, 390 +/-10%, 1W	109561	01121	GB3911	1		
RV1	VARISTOR, 150V +/-10%	474122	09214	V150MA2B	1		
T1	XFMR, EXT HIGH VOLTAGE	510057	89536	510057	1		
T2	XFMR, HI-FREQUENCY	432997	89536	432997	1		
TP1	TERMINAL, TEFLON FEED-THRU	281865	12615	SL-841-777	1		
U1	IC, LIN, OP AMP, MONOLITHIC, J-FET INPUT	429837	12040	LF356F	1		1
VR1	DIODE, ZENER, 9.1V	459917	12969	UZ8709	2		
VR2	DIODE, ZENER, 9.1V	459917	12969	UZ8709	REF		
W1	CABLE	418764	89536	418764	2		
W2	CABLE	418764	89536	418764	REF		
XK4	SOCKET, RELAY	376665	77342	27E501	2		
XK5	SOCKET, RELAY	376665	77342	27E501	REF		

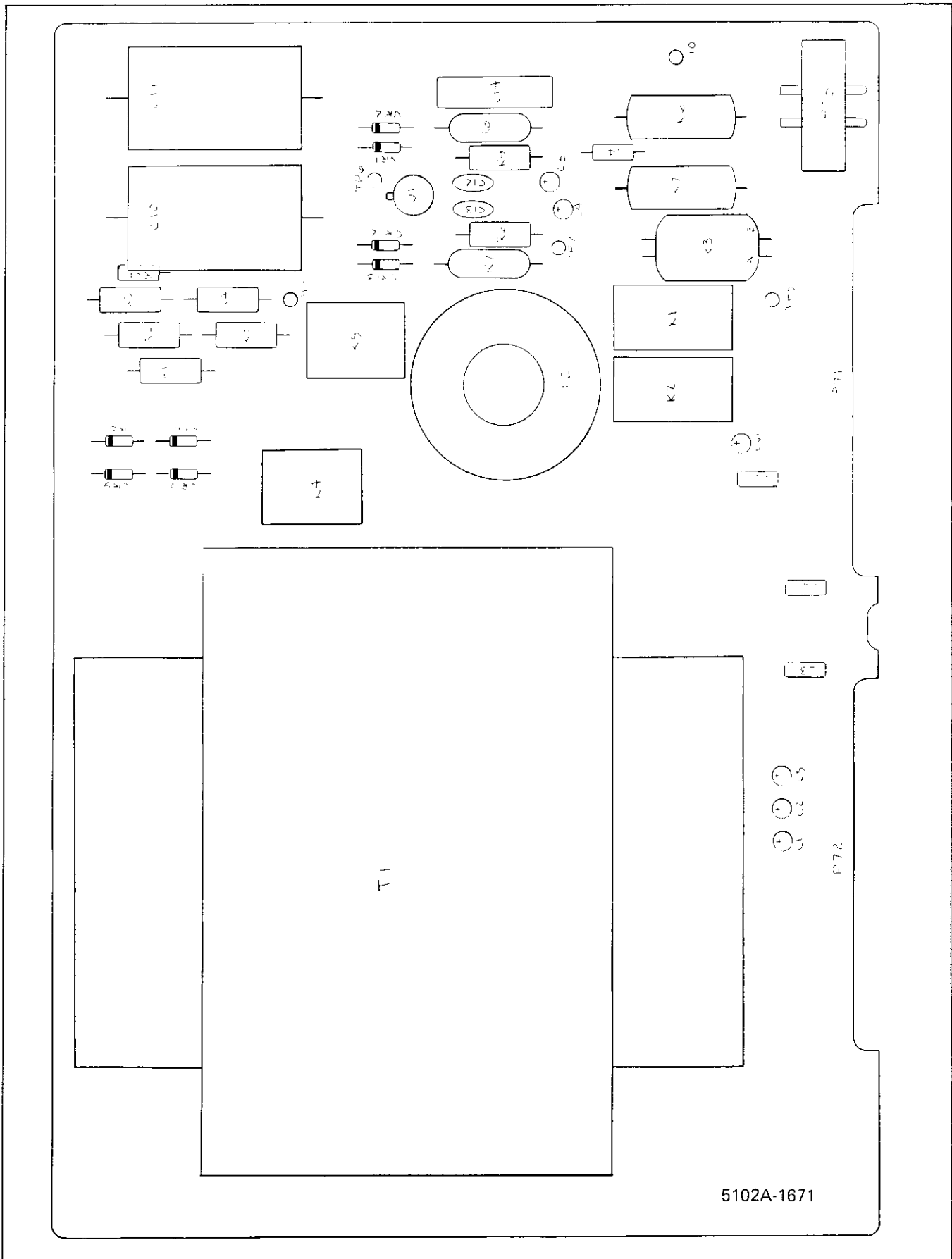
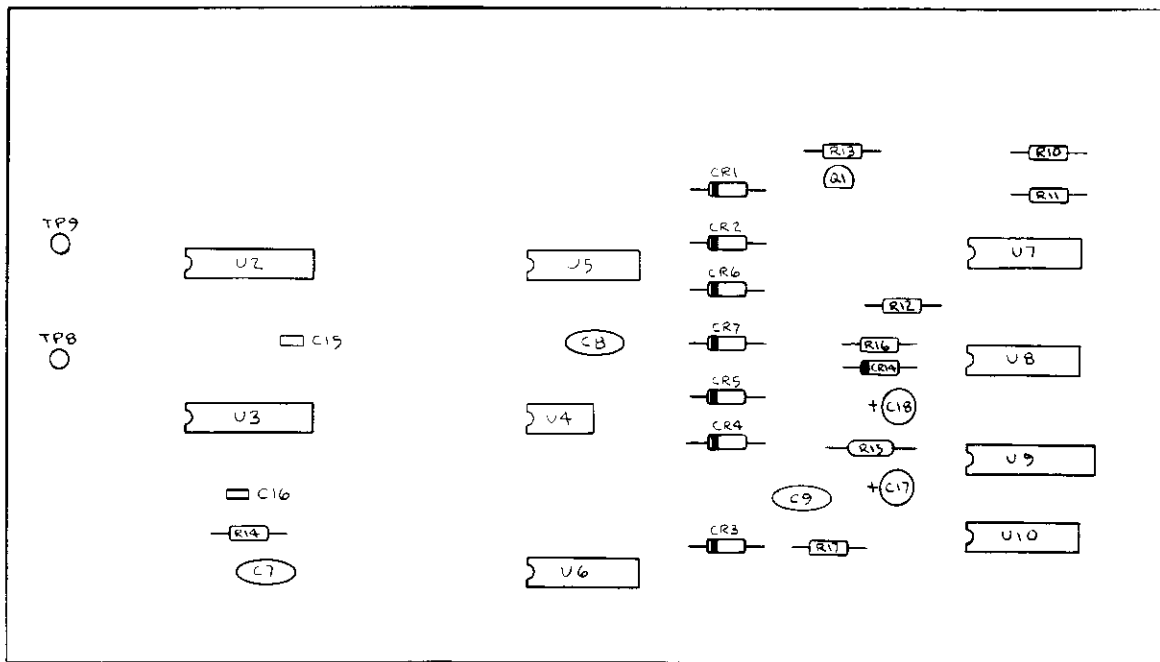

Figure 5-18. A16 Extended High Voltage PCB Assembly, Environmental Case

TABLE 24. A16A1 High Voltage Control PCB Assembly

REF DES	DESCRIPTION	FLUKE STOCK NO.	MFG SPLY CODE	MFG PART NO. OR TYPE	TOT QTY	REC QTY	NO TE
A16A1	⊗ HIGH VOLTAGE CONTROL PCB ASSEMBLY FIGURE 5-18A (5100A-4072)	ORDER	NEXT	HIGHER ASSEMBLY			
C7	CAP, CER, 0.05 UF +/-20%, 100V	149161	56289	55C23A1	3		
C8	CAP, CER, 0.05 UF +/-20%, 100V	149161	56289	55C23A1	REF		
C9	CAP, CER, 0.05 UF +/-20%, 100V	149161	56289	55C23A1	REF		
C15	CAP, CER, 470 PF +/-20%, 100V	358275	72982	8111-A100-W5R-471M	2		
C16	CAP, CER, 470 PF +/-20%, 100V	358275	72982	8111-A100-W5R-471M	REF		
C17	CAP, TA, 39 UF +/-20%, 20V	358234	56289	196D396X0020PE4	2		
C18	CAP, TA, 39 UF +/-20%, 20V	358234	56289	196D396X0020PE4	REF		
CR1	DIODE, SI, HI-SPEED SWITCHING	203323	07910	1N4448	8		2
CR2	DIODE, SI, HI-SPEED SWITCHING	203323	07910	1N4448	REF		
CR3	DIODE, SI, HI-SPEED SWITCHING	203323	07910	1N4448	REF		
CR4	DIODE, SI, HI-SPEED SWITCHING	203323	07910	1N4448	REF		
CR5	DIODE, SI, HI-SPEED SWITCHING	203323	07910	1N4448	REF		
CR6	DIODE, SI, HI-SPEED SWITCHING	203323	07910	1N4448	REF		
CR7	DIODE, SI, HI-SPEED SWITCHING	203323	07910	1N4448	REF		
CR14	DIODE, SI, HI-SPEED SWITCHING	203323	07910	1N4448	REF		
Q1	XSTR, SI, PNP	226290	04713	MPS3640	1		1
R10	RES, DEP, CAR, 47K +/-5%, 1/4W	348896	80031	CR251-4-5P47KT	1		
R11	RES, DEP. CAR, 22K +/-5%, 1/4W	348870	80031	CR251-4-5P22KT	2		
R12	RES, DEP. CAR, 22K +/-5%, 1/4W	348870	80031	CR251-4-5P22KT	REF		
R13	RES, DEP. CAR, 150 +/-5%, 1/4W	343442	80031	CR251-4-5P150ET	1		
R14	RES, DEP. CAR, 4.7K +/-5%, 1/4W	348821	80031	CR251-4-5P4K7T	1		
R15	RES, MTL. FILM, 115K +/-1%, 1/8W	229153	97631	CMF551153F	1		
R16	RES, DEP. CAR, 36K +/-5%, 1/4W	442392	80031	CR251-4-5P36K	1		
R17	RES, DEP. CAR, 10K +/-5%, 1/4W	348839	80031	CR251-4-5P10K	1		
U2	⊗ IC, C-MOS, HEX, BUFFER/INVERTER	381830	02735	CD4050AE	1		1
U3	IC, TTL, HEX, QUAD, "D" TYPE, F/F	393207	01295	SN74LS174N	1		1
U4	IC, DGTL, DUAL PERIPHERAL DRIVER	329706	01295	SN75452P	1		1
U5	IC, TTL, QUAD, 2-INPUT, POS NAND BUFFERS	310201	01295	SN7438N	2		1
U6	IC, TTL, QUAD, 2-INPUT, POS NAND BUFFERS	310201	01295	SN7438N	REF		
U7	⊗ IC, C-MOS, TRIPLE 3-INPUT NAND GATE	418244	12040	MM74C10N	1		1
U8	⊗ IC, C-MOS, DUAL "D" TYPE, F/F	418830	12040	MM74C74	1		
U9	⊗ IC, C-MOS, DUAL, MNSTB/MULTIVBRTR	454017	04713	MC14538BCP	1		
U10	IC, TTL, QUAD, 2-INPUT, POS NAND GATE	393033	01295	SN74LSOON	1		



5100A-1672

Figure 5-18A. A16A1 High Voltage Control PCB Assembly

Table 5-25. A17 Power Amplifier PCB Assembly

REF DES	DESCRIPTION	FLUKE STOCK NO.	MFG SPLY CODE	MFG PART NO. OR TYPE	TOT QTY	REC QTY	NOTE
A17	⊗ POWER AMPLIFIER PCB ASSEMBLY FIGURE 5-19 (5100A-4080T)	458448	89536	458448		REF	
A17A1	POWER TRANSISTOR PCB ASSEMBLY FIGURE 5-20 (5100A-4180)	438606	89536	438606		1	
C1	CAP, TA, 6.8 UF +/-20%, 35V	363713	56289	196D685X0035KA1		2	
C2	CAP, TA, 6.8 UF +/-20%, 35V	363713	56289	196D685X0035KA1		REF	
C3	CAP, MICA, 33 PF +/-5%, 500V	160317	72136	DM15E390J		4	
C4	CAP, CER, 0.22 UF +/-20%, 50V	309849	71590	CW30C224K		3	
C5	CAP, CER, 0.22 UF +/-20%, 50V	309849	71590	CW30C224K		REF	
C6	CAP, POLYSTR, 0.027 +/-10%, 400V	436709	73445	C280MAF/A27K		1	
C7	CAP, MICA, 100 PF +/-5%, 500V	148494	72136	DM15F101J		2	
C8	CAP, CER, 0.05 UF +/-20%, 100V	149161	56289	55C23A1		14	
C9	CAP, CER, 0.05 UF +/-20%, 100V	149161	56289	55C23A1		REF	
C15	CAP, CER, 100 PF +/-2%, 100V	369173	72982	8141-A100-COG-101G		4	
C16	CAP, CER, 100 PF +/-2%, 100V	369173	72982	8141-A100-COG-101G		REF	
C17	CAP, CER, 100 PF +/-2%, 100V	369173	72982	8141-A100-COG-101G		REF	
C18	CAP, CER, 100 PF +/-2%, 100V	369173	72982	8141-A100-COG-101G		REF	
C19	CAP, CER, 0.22 UF +/-20%, 50V	309849	71590	CW30C224K		REF	
C102	CAP, MICA, 470 PF +/-5%, 500V	148429	72136	DM193471J		1	
C103	CAP, MICA, 56 PF +/-1%, 500V	284810	72136	DM15F560F		1	
C104	CAP, CER, 0.05 UF +/-20%, 100V	149161	56289	55C23A1		REF	
C105	CAP, CER, 0.05 UF +/-20%, 100V	149161	56289	55C23A1		REF	
C106	CAP, MICA, 220 PF +/-5%, 500V	170423	72136	DM15F221J		1	
C107	CAP, TA, 2.2 UF +/-20%, 20V	161927	56289	196D225X0020HA1		4	
C108	CAP, MICA, 100 PF +/-5%, 500V	148494	72136	DM15F101J		REF	
C109	CAP, MICA, 1800 PF +/-5%, 500V	148353	72136	DM19F182J		1	
C110	CAP, TA, 1 UF +/-20%, 35V	161919	56289	196D105X0035JA1		1	
C111	CAP, TA, 0.22 UF +/-20%, 35V	161331	56289	196D224X0035HA1		4	
C112	CAP, CER, 0.05 UF +/-20%, 100V	149161	56289	55C23A1		REF	
C113	CAP, TA, 0.22 UF +/-20%, 35V	161331	56289	196D224X0035HA1		REF	
C115	CAP, TA, 47 UF +/-20%, 20V	348516	56289	196D476X0020TE4		4	
C116	CAP, TA, 47 UF +/-20%, 20V	348516	56289	196D476X0020TE4		REF	
C117	CAP, CER, 0.05 UF +/-20%, 100V	149161	56289	55C23A1		REF	
C118	CAP, CER, 0.05 UF +/-20%, 100V	149161	56289	55C23A1		REF	
C119	CAP, CER, 0.05 UF +/-20%, 100V	149161	56289	55C23A1		REF	
C120	CAP, MICA, 39 PF +/-5%, 500V	148544	72136	DM15E390J		1	
C121	CAP, MICA, 33 PF +/-5%, 500V	160317	72136	DM15E390J		REF	
C122	CAP, MICA, 12 PF +/-5%, 500V	175224	72136	DM15C120J		1	
C123	CAP, MICA, 360 PF +/-5%, 500V	325878	72136	DM15F361J		1	
C124	CAP, CER, 0.05 UF +/-20%, 100V	149161	56289	55C23A1		REF	
C125	CAP, CER, 0.05 UF +/-20%, 100V	149161	56289	55C23A1		REF	
C127	CAP, MICA, 33 PF +/-5%, 500V	160317	72136	DM15E390J		REF	
C128	CAP, TA, 0.22 UF +/-20%, 35V	161331	56289	196D224X0035HA1		REF	
C129	CAP, TA, 2.2 UF +/-20%, 20V	161927	56289	196D225X0020HA1		REF	
C130	CAP, TA, 0.22 UF +/-20%, 35V	161331	56289	196D224X0035HA1		REF	
C131	CAP, CER, 0.01 UF +/-20%, 100V	149153	56289	C023B101F103M		2	
C132	CAP, TA, 39 UF +/-20%, 6V	163915	56289	196D396X0006KA1		2	

Table 5-25. A17 Power Amplifier PCB Assembly (cont)

REF DES	DESCRIPTION	FLUKE STOCK NO.	MFG SPLY CODE	MFG PART NO. OR TYPE	TOT QTY	REC QTY	NOTE
C133	CAP, TA, 39 UF +/-20%, 6V	163915	56289	196D396X0006KA1	REF		
C134	CAP, CER, 0.01 UF +/-20%, 100V	149153	56289	C023B101F103M	REF		
C135	CAP, ELECT, 10 UF +/-50, 150V	106351	56289	30D105G150DD	2		
C136	CAP, ELECT, 10 UF +/-50, 150V	106351	56289	30D105G150DD	REF		
C137	CAP, MYLAR, 0.015 UF +/-10%, 100V	182154	14655	DMF2315	1		
C138	CAP, ELECT, 150 UF +50/-10%, 63V	170274	73445	ET151X063A01	2		
C139	CAP, ELECT, 150 UF +50/-10%, 63V	170274	73445	ET151X063A01	REF		
C140	CAP, MICA, 33 PF +/-5%, 500V	160317	72136	DM15E390J	REF		
C141	CAP, CER, 0.05 UF +/-20%, 100V	149161	56289	55C23A1	REF		
C142	CAP, CER, 0.05 UF +/-20%, 100V	149161	56289	55C23A1	REF		
C144	CAP, MICA, 1000 PF +/-5%, 500V	148387	72136	DM19F102J	1		
C145	CAP, TA, 2.2 UF +/-20%, 20V	161927	56289	196D225X0020HA1	REF		
C146	CAP, CER, 0.05 UF +/-20%, 100V	149161	56289	55C23A1	REF		
C147	CAP, CER, 0.05 UF +/-20%, 100V	149161	56289	55C23A1	REF		
C148	CAP, TA, 47 UF +/-20%, 20V	348516	56289	196D476X0020TE4	REF		
C149	CAP, TA, 47 UF +/-20%, 20V	348516	56289	196D476X0020TE4	REF		
C150	CAP, TA, 5.6 UF +/-20, 25V	368969	56289	196D565X0025KA1	1		
C152	CAP, CER, 100 PF +/-10%, 1000V	105593	71590	DD101	1		
CR1	DIODE, SI, HI-SPEED SW	203323	07910	IN4448	30		6
CR2	DIODE, SI, HI-SPEED SW	203323	07910	IN4448	REF		
CR3	DIODE, SI, HI-SPEED SW	203323	07910	IN4448	REF		
CR4	DIODE, SI, HI-SPEED SW	203323	07910	IN4448	REF		
CR5	DIODE, SI, HI-SPEED SW	203323	07910	IN4448	REF		
CR7	DIODE, SI, HI-SPEED SW	203323	07910	IN4448	REF		
CR8	DIODE, SI, HI-SPEED SW	203323	07910	IN4448	REF		
CR9	DIODE, SI, HI-SPEED SW	203323	07910	IN4448	REF		
CR10	DIODE, SI, HI-SPEED SW	203323	07910	IN4448	REF		
CR101	DIODE, SI, HI-SPEED SW	203323	07910	IN4448	REF		
CR102	DIODE, SI, HI-SPEED SW	203323	07910	IN4448	REF		
CR103	DIODE, SI, HI-SPEED SW	203323	07910	IN4448	REF		
CR104	DIODE, SI, HI-SPEED SW	203323	07910	IN4448	REF		
CR105	DIODE, SI, HI-SPEED SW	203323	07910	IN4448	REF		
CR106	DIODE, SI, HI-SPEED SW	203323	07910	IN4448	REF		
CR107	DIODE, SI, RECTIFIER	343491	04713	IN4002	6		2
CR108	DIODE, SI, RECT	343491	04713	IN4002	REF		
CR109	DIODE, SI, HI-SPEED SW	203323	07910	IN4448	REF		
CR110	DIODE, SI, HI-SPEED SW	203323	07910	IN4448	REF		
CR112	DIODE, SI, HI-SPEED SW	203323	07910	IN4448	REF		
CR113	DIODE, SI, HI-SPEED SW	203323	07910	IN4448	REF		
CR114	DIODE, SI, HI-SPEED SW	203323	07910	IN4448	REF		
CR115	DIODE, SI, HI-SPEED SW	203323	07910	IN4448	REF		
CR116	DIODE, SI, HI-SPEED SW	203323	07910	IN4448	REF		
CR117	DIODE, SI, HI-SPEED SW	203323	07910	IN4448	REF		
CR118	DIODE, SI, RECT	343491	04713	IN4002	REF		
CR119	DIODE, SI, RECT	343491	04713	IN4002	REF		
CR120	DIODE, SI, HI-SPEED SW	203323	07910	IN4448	REF		
CR121	DIODE, SI, HI-SPEED SW	203323	07910	IN4448	REF		
CR122	DIODE, SI, HI-SPEED SW	203323	07910	IN4448	REF		
CR123	DIODE, SI, HI-SPEED SW	203323	07910	IN4448	REF		
CR124	DIODE, SI, HI-SPEED SW	203323	07910	IN4448	REF		

Table 5-25. A17 Power Amplifier PCB Assembly (cont)

REF DES	DESCRIPTION	FLUKE STOCK NO.	MFG SPLY CODE	MFG PART NO. OR TYPE	TOT QTY	REC QTY	NOTE
CR125	DIODE, SI, RECT	343491	04713	IN4002	REF		
CR126	DIODE, SI, RECT	343491	04713	IN4002	REF		
CR127	DIODE, FET, CURRENT REG	334714	07910	TCR5315	1	1	
CR128	DIODE, SI, HI-SPEED SW	203323	07910	IN4448	REF		
CR129	DIODE, SI, HI-SPEED SW	203323	07910	IN4448	REF		
H1	NUT, HEX (NOT SHOWN)	184044	73734	8033NP	2		
H3	SPACER, XSTR (NOT SHOWN)	152207	07047	10123DAP	7		
H4	SCREW, SEMS, 4-40 X 1/4 (NOT SHOWN)	185918	89536	185918	6		
K2	RELAY, DRY REED, SPST	404590	71707	CR4503-4.5	2		
K3	RELAY, DRY REED, DPST	340638	95348	F81-5064-1	2		
K4	RELAY, DRY REED, DPST	340638	95348	F81-5064-1	REF		
K5	RELAY, DRY REED, SPST	404590	71707	CR4503-4.5	REF		
K7	RELAY, TELE, TYPE, DPDT	514240	89536	514240	2		
K8	RELAY, TELE, TYPE, DPDT	514240	89536	514240	REF		
K10	RELAY, DRY REED	380725	89536	380725	1		
K11	RELAY, DRY REED,	441949	89536	441949	1		
L1	CHOKER, 6-TURN	320911	89536	320911	1		
Q1	XSTR, SI, PNP	226290	04713	MPS3640	1	1	
Q2	XSTR, SI, NPN	245480	89536	245480	1	1	
Q101	XSTR, FET, N-CHANNEL	370072	89536	370072	2	1	
Q102	XSTR, FET, N-CHANNEL	370072	89536	370072	REF		
Q103	XSTR, SI, NPN	218396	04713	2N3904	5	1	
Q108	XSTR, SI, PNP	341081	07263	2N4121	2	1	
Q109	XSTR, SI, PNP	341081	07263	2N4121	REF		
Q110	XSTR, PWR, SI, PNP	276899	86684	2N5415	3	1	
Q111	XSTR, SI, NPN	218081	04713	MPS6520	1	1	
Q112	XSTR, PWR, SI, NPN	343970	04713	MSPS7104	2	1	
Q113	XSTR, SI, NPN	218396	04713	2N3904	REF		
Q114	XSTR, SI, PNP	266619	07263	PN4888	5	1	
Q115	XSTR, SI, NPN	370684	04713	MPSA42	1	1	
Q116	XSTR, SI, PNP	266619	07263	PN4888	REF		
Q117	XSTR, PWR, SI, NPN	343970	04713	MSPS7104	REF		
Q118	XSTR, PWR, SI PNP	343988	04713	SPS7025	1	1	
Q119	XSTR SET (Q119, Q120)	468926	89536	468926	1	1	
Q120	XSTR, (PART OF Q119 SET)						
Q121	XSTR, SI, NPN	335067	04713	2N3439	4	1	
Q122	XSTR, SI, NPN	335067	04713	2N3439	REF		
Q123	XSTR, PWR, SI, PNP	276899	86684	2N5415	REF		
Q125	XSTR, SI, NPN	335067	04713	2N3439	REF		
Q127	XSTR, SI, PNP	266619	07263	PN4888	REF		
Q128	XSTR, SI, NPN	218396	04713	2N3904	REF		
Q129	XSTR, SI, NPN	218396	04713	2N3904	REF		
Q130	XSTR, SI, PNP	195974	04713	2N3906	2	1	
Q131	XSTR, SI, NPN	335067	04713	2N3439	REF		
Q133	XSTR, PWR, SI, PNP	276899	86684	2N5415	REF		
Q135	XSTR, SI, PNP	195974	04713	2N3906	REF		
Q139	XSTR, SI, PNP	266619	07263	PN4888	REF		
Q140	XSTR, SI, NPN	218396	04713	2N3904	REF		
Q141	XSTR, SI, PNP	266619	07263	PN4888	REF		
RI	RES, DEP. CAR, 22K +/-5%, 1/4W	348870	80031	CR251-4-5P22KT	2		

Table 5-25. A17 Power Amplifier PCB Assembly (cont)

REF DES	DESCRIPTION	FLUKE STOCK NO.	MFG SPLY CODE	MFG PART NO. OR TYPE	TOT QTY	REC QTY	N O T E
R2	RES, DEP. CAR, 22K +/-5%, 1/4W	348870	80031	CR251-4-5P22KT	REF		
R3	RES, DEP. CAR, 150 +/-5%, 1/4W	343442	80031	CR251-4-5P150ET	1		
R4	RES, DEP. CAR, 4.7 +/-5%, 1/4W	348821	80031	CR251-4-5P4K7T	4		
R5	RES, DEP. CAR, 390 +/-5%, 1/4W	441543	80031	CR251-4-5P389ET	3		
R8	RES, DEP. CAR, 15K +/-5%, 1/4W	348854	80031	CR251-4-5P15KT	1		
R9	RES, DEP. CAR, 2K +/-5%, 1/4W	441469	80031	CR251-4-5P2KT	3		
R10	RES, DEP. CAR, 9.1K +/-5%, 1/4W	441691	80031	CR251-4-5P9K1T	1		
R11	RES, DEP. CAR, 3.9K +/-5%, 1/4W	342600	80031	CR251-4-5P3K9T	1		
R12	RES, DEP. CAR, 12K +/-5%, 1/4W	348847	80031	CR251-4-5P12KT	1		
R13	RES, MTL. FILM, 20K +/-1%, 1/8W	291872	91637	CMF552002F	2		
R14	RES, DEP. CAR, 20K +/-5%, 1/4W	441477	80031	CR251-4-5P20KT	1		
R15	RES, MTL. FILM, 20K +/-1%, 1/8W	291872	91637	CMF552002F	REF		
R16	RES, DEP. CAR, 10K +/-5%, 1/4W	348839	80031	CR251-4-5P10KT	18		
R17	RES, VAR, CERMET, 10K +/-10%, 1/2W	285171	89536	285171	1	1	
R18	RES, DEP. CAR, 2.2K +/-5%, 1/4W	343400	80031	CR251-4-5P2K2T	1		
R19	RES, DEP. CAR, 330 +/-5%, 1/4W	368720	80031	CR251-4-5P330ET	1		
R20	RES, MTL. FILM, 24.9K +/-1%, 1/8W	291369	91637	CMF552492F	1		
R21	RES, MTL. FILM, 10K +/-1%, 1/8W	168260	91637	CMF331002F	1		
R22	RES, MTL. FILM, 2K +/-1%, 1/2W	151266	91637	CMF652001F	1		
R23	RES, MTL. FILM, 442 +/-1%, 1/2W	150813	91637	CMF654420F	1		
R24	RES, DEP. CAR, 1K +/-5%, 1/4W	343426	80031	CR251-4-5P1KT	4		
R25	RES, DEP. CAR, 10K +/-5%, 1/4W	348839	80031	CR251-4-5P10KT	REF		
R26	RES, DEP. CAR, 10K +/-5%, 1/4W	348839	80031	CR251-4-5P10KT	REF		
R27	RES, DEP. CAR, 10K +/-5%, 1/4W	348839	80031	CR251-4-5P10KT	REF		
R28	RES, DEP. CAR, 10K +/-5%, 1/4W	348839	80031	CR251-4-5P10KT	REF		
R29	RES, DEP. CAR, 10K +/-5%, 1/4W	348839	80031	CR251-4-5P10KT	REF		
R30	RES, DEP. CAR, 10K +/-5%, 1/4W	348839	80031	CR251-4-5P10KT	REF		
R31	RES, DEP. CAR, 10K +/-5%, 1/4W	348839	80031	CR251-4-5P10KT	REF		
R32	RES, DEP. CAR, 10K +/-5%, 1/4W	348839	80031	CR251-4-5P10KT	REF		
R33	RES, DEP. CAR, 10K +/-5%, 1/4W	348839	80031	CR251-4-5P10KT	REF		
R34	RES, DEP. CAR, 10K +/-5%, 1/4W	348839	80031	CR251-4-5P10KT	REF		
R35	RES, DEP. CAR, 10K +/-5%, 1/4W	348839	80031	CR251-4-5P10KT	REF		
R37	RES, DEP. CAR, 10K +/-5%, 1/4W	348839	80031	CR251-4-5P10KT	REF		
R38	RES, DEP. CAR, 10K +/-5%, 1/4W	348839	80031	CR251-4-5P10KT	REF		
R39	RES, DEP. CAR, 10K +/-5%, 1/4W	348839	80031	CR251-4-5P10KT	REF		
R40	RES, DEP. CAR, 10K +/-5%, 1/4W	348839	80031	CR251-4-5P10KT	REF		
R110	RES, MTL. FILM, 5.90K +/-1%, 1/8W	267351	91637	CMF55901F	1		
R111	RES, MTL. FILM, 18.2K +/-1%, 1/8W	236810	91637	CMF551822F	1		
R112	RES, MTL. FILM, 12.7K +/-1%, 1/8W	217448	91637	CMF551272F	1		
R113	RES, MTL. FILM, 21.5 +/-1%, 1/8W	325639	91637	DMF5521R5F	2		
R114	RES. VAR. CER,ET. 200K +/-20%, 1/2W	381509	11236	190PC204B	1	1	
R115	RES, DEP. CAR, 200K +/-5%, 1/4W	441485	80031	CR251-4-5P200KT	1		
R116	RES, DEP. CAR, 2.7K +/-5%, 1/4W	386490	80031	CR251-4-5P2K7T	1		
R117	RES, MTL. FILM, 61.9 +/-1%, 1/8W	305961	91637	CMF55561R9F	1		
R118	RES, MTL. FILM, 953 +/-1%, 1/8W	288555	91637	CMF559530F	1		
R119	RES, MTL. FILM, 365 +/-1%, 1/8W	459859	91637	CMF553650F	1		
R121	RES, MTL. FILM, 61.9K +/-1%, 1/8W	237230	91637	CMF556192F	1		
R122	RES, MTL. FILM, 4.75K +/-1%, 1/8W	260679	91637	CMF554751F	2		
R123	RES, VAR, CERMET, 500 +/-10%, 1/2W	291120	89536	291120	2	1	
R124	RES, MTL. FILM, 1.78K +/-1%, 1/8W	344366	91637	CMF551781F	2		

Table 5-25. A17 Power Amplifier PCB Assembly (cont)

REF DES	DESCRIPTION	FLUKE STOCK NO.	MFG SPLY CODE	MFG PART NO. OR TYPE	TOT QTY	REC QTY	NO TE
R125	RES, DEP. CAR, 91+/-5%, 1/4W	441683	80031	CR251-4-5P91ET	1		
R126	RES, MTL. FILM, 806 +/-1%, 1/8W	223552	91637	CMF558060F	1		
R127	RES, DEP. CAR, 6.8K +/-5%, 1/4W	368761	80031	CR251-4-5P6K8T	2		
R128	RES, MTL. FILM, 174 +/-1%, 1/8W	343913	91637	CMF551740F	1		
R129	RES, DEP. CAR, 6.8K +/-5%, 1/4W	368761	80031	CR251-4-5P6K8T	REF		
R130	RES, DEP. CAR, 470K +/-5%, 1/4W	342634	80031	CR251-4-5P470KT	1		
R131	RES, DEP. CAR 150K +/-5%, 1/4W	348938	80031	CR251-4-5P150KT	1		
R132	RES, DEP. CAR, 1K +/-5%, 1/4W	343426	80031	CR251-4-5P1KT	REF		
R133	RES, DEP. CAR, 7.5K +/-5%, 1/4W	441667	80031	CR251-4-5P7K5T	3		
R134	RES, DEP. CAR, 470 +/-5%, 1/4W	343434	80031	CR251-4-5P470ET	4		
R135	RES, DEP. CAR, 180 +/-5%, 1/4W	441436	80031	CR251-4-5P180ET	2		
R136	RES, DEP. CAR, 180 +/-5%, 1/4W	441436	80031	CR251-4-5P180ET	REF		
R137	RES, DEP. CAR, 470 +/-5%, 1/4W	343434	80031	CR251-4-5P470ET	REF		
R138	RES, DEP. CAR, 10 +/-5%, 1/4W	340075	80031	CR251-5-5P10ET	3		
R139	RES, DEP. CAR, 390 +/-5%, 1/4W	441543	80031	CR251-4-5P389ET	REF		
R140	RES, DEP. CAR, 9.1 +/-5%, 1/4W	441303	80031	CR251-4-5P9E1T	2		
R141	RES, DEP. CAR, 9.1 +/-5%, 1/4W	441303	80031	CR251-4-5P9E1T	REF		
R142	RES, DEP. CAR, 390 +/-5%, 1/4W	441543	80031	CR251-4-5P389ET	REF		
R143	RES, DEP. CAR, 10 +/-5%, 1/4W	340075	80031	CR251-5-5P10ET	REF		
R144	RES, MTL. FILM, 1.82 +/-1%, 1/8W	293670	91637	CMF551821F	1		
R145	RES, MTL. FILM, 1.43K +/-1%, 1/8W	325662	91637	CMF551431F	1		
R146	RES, MTL. FILM, 294 +/-1%, 1/8W	288472	91637	CMF552940F	1		
R147	RES, MTL. FILM, 4.99K +/-1%, 1/8W	168252	91637	DMF554991F	2		
R148	RES, MTL. FILM, 4.99K +/-1%, 1/8W	168252	91637	DMF554991F	REF		
R149	RES, DEP. CAR, 75K +/-5%, 1/4W	394130	80031	CR251-4-5P75KT	1		
R150	RES, VAR, CERMET, 50K +/-10%, 1/2W	288290	90536	288290	3	1	
R151	RES, MTL. FILM, 3.83K +/-1%, 1/8W	235143	91637	CMF553831F	1		
R152	RES, MTL. FILM, 1.37K +/-1%, 1/8W	236752	91627	CMF551372F	1		
R153	RES, MTL. FILM, 15.4K +/-1%, 1/8W	261651	91637	CMF551542F	2		
R154	RES, COMP, 5.1M +/-5%, 1/4W	296467	01121	CB5155	2		
R155	RES, VAR, CERMET, 50K +/-10%, 1/2W	288290	90536	288290	REF		
R156	RES, DEP. CAR, 15 +/-5%, 1/4W	348755	80031	CR251-4-5P15ET	1		
R157	RES, COMP, 2K +/-5%, 2W	276998	01121	HB2025	1		
R158	RES, MTL. FILM, 2.05K +/-1%, 1/8W	293704	91637	CMF553051F	1		
R159	RES, MTL. FILM, 8.25K +/-1%, 1/2W	192492	91637	CMF658251F	1		
R160	RES, DEP. CAR, 100K +/-5%, 1/4W	348920	80031	CR251-4-5P100KT	3		
R162	RES, MTL. FILM, 21.5 +/-1%, 1/8W	325639	91637	DMF5521R5F	REF		
R163	RES, COMP, 11K +/-5%, 1/2W	108613	01121	EB1135	2		
R164	RES, MTL. FILM, 1.58K +/-1%, 1/8W	344341	91637	CMF551581F	1		
R165	RES, VAR, CERMET, 200 +/-10%, 1/2W	285148	89536	285148	1	1	
R166	RES, MTL. FILM, 604 +/-1%, 1/8W	320309	91637	CMF556040F	1		
R167	RES, DEP. CAR, 10 +/-5%, 1/4W	340075	80031	CR251-5-5P10ET	REF		
R168	RES, COMP, 11K +/-5%, 1/2W	108613	01121	EB1135	REF		
R169	RES, MTL. FILM, 215 +/-1%, 1/8W	343533	91637	CMF552150F	1		
R170	RES, DEP. CAR, 4.7 +/-5%, 1/4W	348821	80031	CR251-4-5P4K7T	REF		
R171	RES, DEP. CAR, 2K +/-5%, 1/4W	441469	80031	CR251-4-5P2KT	REF		
R172	RES, DEP. CAR, 4.7 +/-5%, 1/4W	348821	80031	CR251-4-5P4K7T	REF		
R173	RES, DEP. CAR, 91K +/-5%, 1/4W	441709	80031	CR251-4-5P91KT	2		
R174	RES, DEP. CAR, 470 +/-5%, 1/4W	343434	80031	CR251-4-5P470ET	REF		
R175	RES, DEP. CAR, 56 +/-5%, 1/4W	342618	80031	CR251-4-5P56ET	4		

Table 5-25. A17 Power Amplifier PCB Assembly (cont)

REF DES	DESCRIPTION	FLUKE STOCK NO.	MFG SPLY CODE	MFG PART NO. OR TYPE	TOT QTY	REC QTY	NO TE
R176	RES, DEP. CAR, 56 +/-5%, 1/4W	342618	80031	CR251-4-5P56ET	REF		
R177	RES, DEP. CAR, 470 +/-5%, 1/4W	343434	80031	CR251-4-5P470ET	REF		
R178	RES, DEP. CAR, 91K +/-5%, 1/4W	441709	80031	CR251-4-5P91KT	REF		
R179	RES, DEP. CAR, 100K +/-5%, 1/4W	348920	80031	CR251-4-5P100KT	REF		
R180	RES, DEP. CAR, 51 +/-5%, 1/4W	414540	80031	CR251-4-5P51ET	1		
R181	RES, DEP. CAR, 240 +/-5%, 1/4W	376624	80031	CR251-4-5P240ET	2		
R182	RES, COMP, 1.6 +/-5%, 1/2W	218727	01121	EB1G65	2		
R183	RES, COMP, 1.6 +/-5%, 1/2W	218727	01121	EB1G65	REF		
R184	RES, DEP. CAR, 240 +/-5%, 1/4W	376624	80031	CR251-4-5P24-0ET	REF		
R185	RES, DEP. CAR, 10K +/-5%, 1/4W	348839	80031	CR251-4-5P10KT	REF		
R186	RES, MTL. FILM, 15.4K +/-1%, 1/8W	261651	91637	CMF551542F	REF		
R187	RES, DEP. CAR, 56K +/-5%, 1/4W	441626	80031	CR251-4-5P56KT	1		
R188	RES, MTL. FILM, 2.6K +/-1%, 1/8W	289587	91637	CMF552671F	1		
R189	RES, MTL. FILM, 1.40K +/-1%, 1/8W	344333	91637	CMF551401F	1		
R190	RES, MTL. FILM, 200 +/-1%, 1/8W	245340	91637	CMF55R201F	1		
R191	RES, DEP. CAR, 2K +/-5%, 1/4W	441469	80031	CR251-4-5P2KT	REF		
R192	RES, COMP, 5.1M +/-5%, 1/4W	296467	01121	CB5155	REF		
R193	RES, VAR, CERMET, 50K +/-10%, 1/2W	288290	90536	288290	REF		
R194	RES, MTL. FILM, 2K +/-1%, 1/8W	235226	91637	CMF552001F	1		
R195	RES, DEP. CAR, 100K +/-5%, 1/4W	348920	80031	CR251-4-5P100KT	REF		
R196	RES, DEP. CAR, 27K +/-5%, 1/4W	441501	80031	CR251-4-5P27KT	1		
R197	RES, DEP. CAR, 750 +/-5%, 1/4W	441659	80031	CR251-4-5P750ET	1		
R198	RES, DEP. CAR, 100 +/-5%, 1/4W	348771	80031	CR251-4-5P100ET	3		
R199	RES, DEP. CAR, 100 +/-5%, 1/4W	348771	80031	CR251-4-5P100ET	REF		
R200	RES, DEP. CAR, 22 +/-5%, 1/4W	381145	80031	CR251-4-5P22ET	1		
R201	RES, DEP. CAR, 10K +/-5%, 1/4W	348839	80031	CR251-4-5P10KT	REF		
R202	RES, MTL. FILM, 4.75K +/-1%, 1/8W	260679	91637	CMF554751F	REF		
R203	RES, VAR, CERMET, 500 +/-10%, 1/2W	291120	89536	291120	REF		
R204	RES, MTL. FILM, 1.78K +/-1%, 1/8W	344366	91637	CMF551781F	REF		
R205	RES, MTL. FILM, 10 +/-1%, 1/8W	268789	91637	CMF55A100F	2		
R206	RES, DEP. CAR, 300K +/-5%, 1/4W	441535	80031	CR251-4-5P300KT	2		
R207	RES, DEP. CAR, 300K +/-5%, 1/4W	441535	80031	CR251-4-5P300KT	REF		
R208	RES, DEP. CAR, 4.7 +/-5%, 1/4W	348821	80031	CR251-4-5P4K7T	REF		
R209	RES, DEP. CAR, 7.5K +/-5%, 1/4W	441667	80031	CR251-4-5P7K5T	REF		
R210	RES, DEP. CAR, 200 +/-5%, 1/4W	441451	80031	CR251-4-5P200ET	2		
R211	RES, DEP. CAR, 7.5K +/-5%, 1/4W	441667	80031	CR251-4-5P7K5T	REF		
R212	RES, DEP. CAR, 200 +/-5%, 1/4W	441451	80031	CR251-4-5P200ET	REF		
R213	RES, WW, PWR, 0.15 +/-5%, 2W	325712	89536	325712	2	1	
R214	RES, WW, PWR, 0.15 +/-5%, 2W	325712	89536	325712	REF		
R216	RES, DEP. CAR, 1K +/-5%, 1/4W	343426	80031	CR251-4-5P1KT	REF		
R217	RES, MTL. FILM, 100 +/-1%, 1/8W	168195	91637	CMF55R101F	1		
R218	RES, MTL. FILM, 12.1 +/-1%, 1/8W	296608	91637	CMF5512R1F	2		
R219	RES, MTL. FILM, 12.1 +/-1%, 1/8W	296608	91637	CMF5512R1F	REF		
R220	RES, MTL. FILM, 10 +/-1%, 1/8W	268789	91637	CMF55A100F	REF		
R221	RES, DEP. CAR, 1K +/-5%, 1/4W	343426	80031	CR251-4-5P1KT	REF		
R222	RES, DEP. CAR, 56 +/-5%, 1/4W	342618	80031	CR251-4-5P56ET	REF		
R223	RES, DEP. CAR, 56 +/-5%, 1/4W	342618	80031	CR251-4-5P56ET	REF		
R224	RES, DEP. CAR, 100 +/-5%, 1/4W	348771	80031	CR251-4-5P100ET	REF		
R225	RES, COMP, 10M +/-5%, 1/4W	194944	01121	CB1065	2		
R226	RES, COMP, 10M +/-5%, 1/4W	194944	01121	CB1065	REF		

Table 5-25. A17 Power Amplifier PCB Assembly (cont)

REF DES	DESCRIPTION	FLUKE STOCK NO.	MFG SPLY CODE	MFG PART NO. OR TYPE	TOT QTY	REC QTY	N O T E
U1	⊗ IC, C-MOS, NAND GATE, DUAL, FOUR-INPUT	429407	12040	MM74C20N	1	1	
U2	⊗ IC, C-MOS, HEX/INVERTERS	381830	02735	CD4050AE	1	1	
U3	IC, TTL, HEX, QUAD "D" TYPE, F/F	393207	01295	SN74LS174N	1	1	
U4	IC, HEX, QUAD, "D" TYPE, F/F	393215	01295	SN74LS175N	1	1	
U5	IC, TTL, QUAD, 2-IN, POS NAND BUFF W/OPN	310201	01295	SN7438N	1	1	
U6	IC, DUAL, PERIPHERAL DRIVER	329706	01295	SN75452P	2	1	
U7	IC, DUAL, PERIPHERAL DRIVER	329706	01295	SN75452P	REF		
U8	IC, TTL, QUAD, 2-INPUT, POS NOR GATE	288845	01295	SN7402N	1	1	
U101	IC, LIN-OP-AMP	402669	12040	LM324N	1	1	
U102	IC, LIN, OP AMP	329912	12040	LM318	1	1	
U103	OPTO-ISOLATOR MATCHED SET (U103/U107)	418434	03911	CL,/8501M	1	1	
U104	IC, OP AMP	225961	24355	AD3092	3	1	
U105	IC, OP AMP	225961	24355	AD3092	REF		
U106	IC, OP AMP	225961	24355	AD3092	REF		
U107	OPTO-ISOLATOR (PART OF U103 SET)				REF		
U108	OPTO-ISOLATOR	312298	29083	Q1813	3	1	
U109	OPTO-ISOLATOR	312298	29083	Q1813	REF		
U110	OPTO-ISOLATOR	312298	29083	Q1813	REF		
VR101	DIODE, ZENER, 3.9V	113316	07910	IN748	4	1	
VR102	DIODE, ZENER 10.0V	246611	07910	IN961B	1	1	
VR103	DIODE, ZENER, 3.9V	113316	07910	IN748	REF		
VR104	DIODE, ZENER, 4.3V	180455	07910	IN749A	2	1	
VR105	DIODE, ZENER, 6.2V	325811	07910	IN753A	1	1	
VR106	DIODE, ZENER, 4.3V	180455	07910	IN749A	REF		
VR108	DIODE, ZENER, 3.9V	113316	07910	IN748	REF		
VR109	DIODE, ZENER, 3.9V	113316	07910	IN748	REF		
VR110	DIODE, ZENER, 5.6V	277236	07910	IN752A	2	1	
VR111	DIODE, ZENER, 5.6V	277236	07910	IN752A	REF		
XK7	SOCKET, RELAY	376665	77342	27E501	2		
XK8	SOCKET, RELAY	376665	77342	27E501	REF		
XQ119	HEAT SINK, ALUMINUM	386235	13103	6032D	2		
XQ120	HEAT SINK, ALUMINUM	386235	13103	6032D	REF		
XQ122	HEAT SINK, PRESS-ON	418384	13103	2225B	5		
XQ123	HEAT SINK, PRESS-ON	418384	13103	2225B	REF		
XQ125	HEAT SINK, PRESS-ON	418384	13103	2225B	REF		
XQ131	HEAT SINK, PRESS-ON	418384	13103	2225B	REF		
XQ133	HEAT SINK, PRESS-ON	418384	13103	2225B	REF		

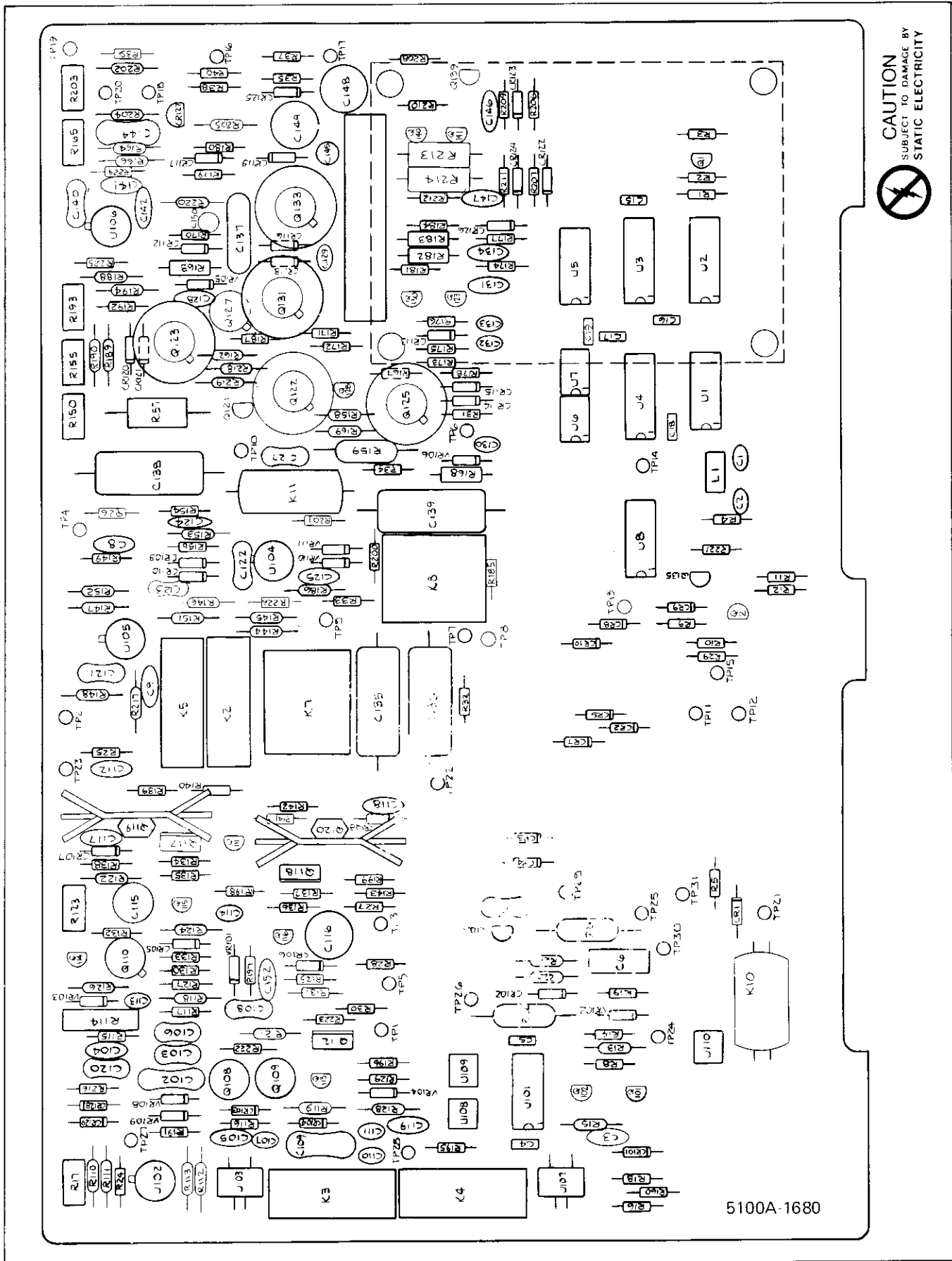
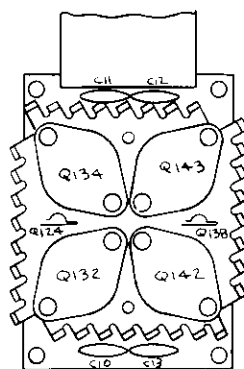

Figure 5-19. A17 Power Amplifier PCB Assembly

Table 5-26. A17A1 Power Transistor PCB Assembly

REF DES	DESCRIPTION	FLUKE STOCK NO.	MFG SPLY CODE	MFG PART NO. OR TYPE	TOT QTY	REC QTY	N O T E
A17A1	POWER TRANSISTOR PCB ASSEMBLY FIGURE 5-20 (5100A-4180)	438606	89536	438606	REF		
C10	CAP, CER, 0.1 UF +/-20%, 100V	149146	56289	33C41B6	4		
C11	CAP, CER, 0.1UF+/-20%, 100V	149146	56289	33C41B6	REF		
C12	CAP, CER, 0.1UF+/-20%, 100V	149146	56289	33C41B6	REF		
C13	CAP, CER, 0.1UF+/-20%, 100V	149146	56289	33C41B6	REF		
H1	SCREW, PHP, 6-32 X 1/2 (NOT SHOWN)	177030	89536	177030	8		
MP1	HEAT SINK, XSTR (NOT SHOWN)	425165	89536	425165	1		
MP2	HEAT SINK, MTG	312413	91502	RU67B1U	2		
MP3	INSULATOR, XSTR	473165	55285	7403-08-FR-05	4		
MP4	CONN, RCPTL, TO FLAT CABLE (NOT SHOWN)	284281	00779	380598-2	10		
Q124	XSTR, SI, NPN	218081	04713	MPS6520	2	1	
Q132	XSTR, PWR, SI, NPN	313213	02735	2N5240	2		
Q134	XSTR, PWR, SI, NPN	313213	02735	2N5240	REF		
Q138	XSTR, SI, NPN	218081	04713	MPS6520	REF		
Q142	XSTR, PWR, CI, NPN	429092	04713	2N6055	1		
Q143	XSTR, PWR, SI, PNP	429084	04713	2N6054	1	1	
W1	CABLE, JUMPER, FLAT	418764	00779	1-86942-7	1		



5100A-1680

Figure 5-20. A17A1 Power Transistor PCB Assembly

Table 5-27. A18 Oscillator PCB Assembly

REF DES	DESCRIPTION	FLUKE STOCK NO.	MFG SPLY CODE	MFG PART NO. OR TYPE	TOT QTY	REC QTY	NOTE
A18	⊗ OSCILLATOR PCB ASSEMBLY FIGURE 5-21 (5100A-4090T)	458455	89536	458455	REF		
C1	CAP, CER, 0.22 UF +/-20%, 50V	309849	71590	CW30C224K	8		
C2	CAP, CER, 0.22 UF +/-20%, 50V	309849	71590	CW30C224K	REF		
C3	CAP, CER, 0.22UF+/-20%, 50V	309849	71590	CW30C224K	REF		
C4	CAP, CER, 0.22UF+/-200%, 50V	309849	71590	CW30C224K	REF		
C5	CAP, TA, 10 UF +/-20%, 20V	330662	56289	196D106X0020KA1	8		
C7	CAP, CER, 0.1 UF +/-20%, 100V	149146	56289	33C41B6	1		
C8	CAP, MICA, 33 PF +/-5%, 500V	160317	72136	DM15E330J	1		
C9	CAP, TA, 10 UF +/-20%, 20V	330662	56289	196D106X0020KA1	REF		
C10	CAP, POLYPRPLN, 0.793 UF +/-1%, 50V	413591	89536	413591	2		
C11	CAP, POLYPRPLN, 0.786 UF +/-1%, 50V	422998	89536	422998	2		
C12	CAP, POLYPRPLN, 0.00715 UF +/-1%, 50V	422980	89536	422980	2		
C13	CAP, MICA, 768 PF +/-1%, 300V	413609	72136	DM15F768F	2		
C14	CAP, VAR, 5-50 PF, 250V	404301	56289	GKC50000	2		
C15	CAP, CER, 0.22 UF +/-20%, 50V	309849	71590	CW30C224K	REF		
C16	CAP, CER, 0.22 UF +/-20%, 50V	309849	71590	CW30C224K	REF		
C17	CAP, POLYPRPLN, 0.793 UF +/-1%, 50V	413591	89536	413591	REF		
C18	CAP, POLYPRPLN, 0.786 UF +/-1%, 50V	422998	89536	422998	REF		
C19	CAP, POLYPRPLN, 0.00715 UF +/-1%, 50V	422980	89536	422980	REF		
C20	CAP, MICA, 768 PF +/-1%, 300V	413609	72136	DM15F768F	REF		
C21	CAP, VAR, 5-50 PF, 250V	404301	56289	GKC50000	REF		
C22	CAP, CER, 0.22 UF +/-20%, 50V	309849	71590	CW30C224K	REF		
C23	CAP, CER, 0.22 UF +/-20%, 50V	309849	71590	CW30C224K	REF		
C24	CAP, TA, 10 UF +/-20%, 20V	330662	56289	196D106X0020KA1	REF		
C25	CAP, TA, 10 UF +/-20%, 20V	330662	56289	196D106X0020KA1	REF		
C26	CAP, TA, 10 UF +/-20%, 20V	330662	56289	196D106X0020KA1	REF		
C27	CAP, TA, 10 UF +/-20%, 20V	330662	56289	196D106X0020KA1	REF		
C28	CAP, TA, 10 UF +/-20%, 20V	330662	56289	196D106X0020KA1	REF		
C29	CAP, TA, 10 UF +/-20%, 20V	330662	56289	196D106X0020KA1	REF		
C36	CAP, MYLAR, 1 UF +/-20%, 200V	106450	89536	106450	1		
C40	CAP, 2 PF, 500V	175208	72136	DM15C020D	2		
C41	CAP, 2 PF, 500V	175208	72136	DM15C020D	REF		
C42	CAP, MICA, 47 PF +/-5%, 500V	148536	72136	DM15E470J	2		
C43	CAP, MICA, 47 PF +/-5%, 500V	148536	72136	DM15E470J	REF		
C44	CAP, TA, 68 UF +/-20%, 15V	193615	56289	196D686X0015TE4	1		
C45	CAP, MICA, 56 PF +/-5%, 500V	148528	72136	DM15F560J	1		
CR1	DIODE, HOT CARRIER	369595	07263	FH1100	4	1	
CR2	DIODE, HOT CARRIER	369595	07263	FH1100	REF		
CR3	DIODE, HOT CARRIER	369595	07263	FH1100	REF		
CR4	DIODE, HOT CARRIER	369595	07263	FH1100	REF		
CR5	DIODE, SI, HI-SPEED SWICING	203323	07910	IN4448	7	2	
CR6	DIODE, SI, HI-SPEED SWICING	203323	07910	IN4448	REF		
CR7	DIODE, SI, HI-SPEED SWICING	203323	07910	IN4448	REF		
CR8	DIODE, SI, HI-SPEED SWICING	203323	07910	IN4448	REF		
CR9	DIODE, SI, HI-SPEED SWICING	203323	07910	IN4448	REF		
CR10	DIODE, SI, HI-SPEED SWICING	203323	07910	IN4448	REF		
CR11	DIODE, SI, HI-SPEED SWICING	203323	07910	IN4448	REF		
CR12	RECTIFIER BRIDGE	418582	83003	VM08	1	1	

Table 5-27. A18 Oscillator PCB Assembly (cont)

REF DES	DESCRIPTION	FLUKE STOCK NO.	MFG SPLY CODE	MFG PART NO. OR TYPE	TOT QTY	REC QTY	N O T E
K1	COIL, REED RELAY	272070	71707	U-D-6-P	2		
	SWITCH, DRY REED	198267	12617	MRH-DT	2		
	SWITCH, DRY REED	219097	12617	MSRH-2	2		
K2	COIL, REED RELAY	272070	71707	U-D-6-P	REF		
	SWITCH, DRY REED	198267	12617	MRH-DT	REF		
	SWITCH, DRY REED	219097	12617	MSRH-2	REF		
K3	RELAY, DRY REED	340638	95348	F81-5064-1	2		
K4	RELAY, DRY REED	404590	71707	CR4503-4.5	2		
K5	RELAY, DRY REED	340638	95348	F81-5064-1	REF		
K6	RELAY, DRY REED	404590	71707	CR4503-4.5	REF		
L1	CHOKE, 6-TURN	320911	89536	320911	3		
L2	CHOKE, 6-TURN	320911	89536	320911	REF		
L3	CHOKE, 6-TURN	320911	89536	320911	REF		
Q1	XSTR, FET, N-CHANNEL	376475	89536	376475	11		3
Q2	XSTR, FET, N-CHANNEL	376475	89536	376475	REF		
Q3	XSTR, FET, N-CHANNEL	376475	89536	376475	REF		
Q4	XSTR, FET, N-CHANNEL	376475	89536	376475	REF		
Q5	XSTR, FET, N-CHANNEL	376475	89536	376475	REF		
Q6	XSTR, FET, N-CHANNEL	376475	89536	376475	REF		
Q7	XSTR, FET, N-CHANNEL	376475	89536	376475	REF		
Q8	XSTR, FET, N-CHANNEL	376475	89536	376475	REF		
Q9	XSTR, FET, N-CHANNEL	376475	89536	376475	REF		
Q10	XSTR, FET, N-CHANNEL	376475	89536	376475	REF		
Q11	XSTR, FET, N-CHANNEL	376475	89536	376475	REF		
Q12	XSTR, SI, PNP	226290	04713	MPS3640	1		1
Q14	⊗ XSTR, FET, P-CHANNEL, MOS	306142	89536	306142	8		2
Q15	⊗ XSTR, FET, P-CHANNEL, MOS	306142	89536	306142	REF		
Q16	⊗ XSTR, FET, P-CHANNEL, MOS	306142	89536	306142	REF		
Q17	⊗ XSTR, FET, P-CHANNEL, MOS	306142	89536	306142	REF		
Q18	⊗ XSTR, FET, P-CHANNEL, MOS	306142	89536	306142	REF		
Q19	⊗ XSTR, FET, P-CHANNEL, MOS	306142	89536	306142	REF		
Q20	⊗ XSTR, FET, P-CHANNEL, MOS	306142	89536	306142	REF		
Q21	⊗ XSTR, FET, P-CHANNEL, MOS	306142	89536	306142	REF		
Q23	XSTR, SI, PNP	195974	04713	2N3906	1		
Q24	XSTR, SI, NPN	218396	04713	2N3904	1		
R1	RES, VAR, CERMET, 5K +/-10%, 1/2W	288282	89536	288282	1		1
R2	RES, MTL. FILM, 4.991K +/-1%, 1/8W	168252	91637	CMF554991F	8		
R3	RES, DEP. CAR, 150K +/-5%, 1/4W	348938	80031	CR251-4-5P150KT	1		
R4	RES, DEP. CAR, 3.3K +/-5%, 1/4W	348813	80031	CR251-4-5P3K3T	2		
R5	RES, DEP. CAR, 100K +/-5%, 1/4W	348920	80031	CR251-4-5P100KT	4		
R6	RES, DEP. CAR, 100K +/-5%, 1/4W	348920	80031	CR251-4-5P100KT	REF		
R7	RES, MTL. FILM, 4.991K +/-1%, 1/8W	168252	91637	CMF554991F	REF		
R8	RES, DEP. CAR, 150 +/-5%, 1/4W	343442	80031	CR251-4-5P150ET	2		
R9	RES, MTL. FILM, 4.991K +/-1%, 1/8W	168252	91637	CMF554991F	REF		
R10	RES, DEP. CAR, 3.3K +/-5%, 1/4W	348813	80031	CR251-4-5P3K3T	REF		
R11	RES, MTL. FILM, 4.991K +/-1%, 1/8W	168252	91637	CMF554991F	REF		
R12	RES, MTL. FILM, 3.65K +/-1%, 1/8W	293779	91637	CMF553651F	4		
R13	RES, MTL. FILM, 12.4K +/-1%, 1/8W	261644	91637	CMF551242F	1		
R14	RES, MTL. FILM, 4.991K +/-1%, 1/8W	168252	91637	CMF554991F	REF		
R15	RES, MTL. FILM, 4.991K +/-1%, 1/8W	168252	91637	CMF554991F	REF		

Table E-27. A18 Oscillator PCB Assembly (cont)

REF DES	DESCRIPTION	FLUKE STOCK NO.	MFG SPLY CODE	MFG PART NO. OR TYPE	TOT QTY	REC QTY	NO TE
R16	RES, MTL. FILM, 10K +/-1%, 1/8W	168260	91637	CMF551002F	2		
R17	RES, MTL. FILM, 20K +/-1%, 1/8W	291872	91637	CMF552002F	4		
R18	RES, MTL. FILM, 20K +/-1%, 1/8W	291872	91637	CMF552002F	REF		
R19	RES, DEP. CAR, 36K +/-5%, 1/4W	442392	80031	CR251-4-5P36KT	1		
R20	RES, DEP. CAR, 3.9K +/-5%, 1/4W	342600	80031	CR251-4-5P3K9T	1		
R21	RES, MTL. FILM, 4.991K +/-1%, 1/8W	168252	91637	CMF554991F	REF		
R22	RES, MTL. FILM, 4.991K +/-1%, 1/8W	168252	91637	CMF554991F	REF		
R23	RES, MTL. FILM, 10K +/-1%, 1/8W	168260	91637	CMF551002F	REF		
R24	RES, MTL. FILM, 20K +/-1%, 1/8W	291872	91637	CMF552002F	REF		
R25	RES, MTL. FILM, 20K +/-1%, 1/8W	291872	91637	CMF552002F	REF		
R26	RES, DEP. CAR, 47K +/-5%, 1/4W	348896	80031	CR251-4-5P47KT	6		
R27	RES, DEP. CAR, 47K +/-5%, 1/4W	348896	80031	CR251-4-5P47KT	REF		
R28	RES, DEP. CAR, 47K +/-5%, 1/4W	348896	80031	CR251-4-5P47KT	REF		
R29	RES, DEP. CAR, 47K +/-5%, 1/4W	348896	80031	CR251-4-5P47KT	REF		
R30	RES, DEP. CAR, 47K +/-5%, 1/4W	348896	80031	CR251-4-5P47KT	REF		
R31	RES, DEP. CAR, 47K +/-5%, 1/4W	348896	80031	CR251-4-5P47KT	REF		
R32	RES, DEP. CAR, 10K +/-5%, 1/4W	348839	80031	CR251-4-5P10KT	3		
R33	RES, DEP. CAR, 150 +/-5%, 1/4W	343442	80031	CR251-4-5P150ET	REF		
R37	RES, DEP. CAR, 1K +/-5%, 1/4W	343426	80031	CR251-4-5P1KT	2		
R40	RES, VAR, CERMET, 100K +/-10%, 1/2W	288308	89536	288308	1	1	
R41	RES, MTL. FILM, 1.10K +/-1%, 1/8W	241497	91637	CMF551101F	1		
R42	RES, MTL. FILM, 3.65K +/-1%, 1/8W	293779	91637	CMF553651F	REF		
R43	RES, MTL. FILM, 3.65K +/-1%, 1/8W	293779	91637	CMF553651F	REF		
R44	RES, MTL. FILM, 3.65K +/-1%, 1/8W	293779	91637	CMF553651F	REF		
R45	RES, DEP. CAR, 100K +/-5%, 1/4W	348920	80031	CR251-4-5P100KT	REF		
R46	RES, DEP. CAR, 470K +/-5%, 1/4W	342634	80031	CR251-4-5P470KT	2		
R47	RES, DEP. CAR, 100K +/-5%, 1/4W	348920	80031	CR251-4-5P100KT	REF		
R48	RES, DEP. CAR, 470K +/-5%, 1/4W	342634	80031	CR251-4-5P470KT	REF		
R49	RES, DEP. CAR, 510 +/-5%, 1/4W	441600	80031	CR251-4-5P510ET	1		
R50	RES, VAR, CERMET, 1K +/-10%, 1/2W	285155	89536	285155	1	1	
R51	RES, MTL. FILM, 41.2K +/-1%, 1/8W	289538	91637	CMF554122F	1		
R52	RES, MTL. FILM, 18.2K +/-1%, 1/8W	236810	91637	CMF551822F	1		
R53	RES, MTL. FILM, 1K +/-1%, 1.8W	168229	91637	CMF551001F	1		
R54	RES, DEP. CAR, 10K +/-5%, 1/4W	348839	80031	CR251-4-5P10KT	REF		
R55	RES, DEP. CAR, 10K +/-5%, 1/4W	348839	80031	CR251-4-5P10KT	REF		
R56	RES, MTL. FILM, 523K +/-1%, 1/8W	260752	91637	CMF555233F	1		
R57	RES, MTL. FILM, 100 +/-1%, 1/8W	168195	91637	CMF551000F	1		
R58	RES, MTL. FILM, 1.62M +/-1%, 1/8W	446633	91637	CMF551624F	1		
U1	IC, LIN, OP AMP	483495	89536	483495	2	1	
U2	IC, LIN, OP AMP	483495	89536	483495	REF		
U3	IC, OP AMP	271502	12040	LM301A	2	1	
U4	IC, LIN, OP AMP	429837	12040	LF356H	2	1	
U5	IC, LIN, OP AMP	429837	12040	LF356H	REF		
U6	IC, TTL, QUAD, 2-INPUT, POS NAND BUFFER	310201	01295	SN7438N	2	1	
U7	IC, HEX, BUFFER/DRIVER	418236	12040	DM7407	1	1	
U8	IC, TTL, LO-PWR, HEX, QUAD "D"-TYPE, F/F	393215	01295	SN74LS175N	2	1	
U9	IC, TTL, LO-PWR, HEX, QUAD "D"-TYPE, F/F	393215	01295	SN74LS175N	REF		
U10	⊗ IC, C-MOS, TRIPLE, 3-INPUT, NAND GATE	418244	12040	MM74C10N	1	1	
U11	⊗ IC, C-MOS, HEX, BUFFER/INVERTERS	381830	02735	CD4050A3	2	1	
U12	⊗ IC, C-MOS, HEX, BUFFER/INVERTERS	381830	02735	CD4050A3	REF		
U13	IC, TTL, QUAD, 2-INPUT, POS NAND BUFFER	310201	01295	SN7438N	REF		
U14	IC, OP AMP	271502	12040	LM301A	REF		
VR1	DIODE, ZENER, 5.6V	277236	07910	IN752A	1	1	
VR2	DIODE, ZENER, 5.1V	159798	07910	IN751A	1	1	

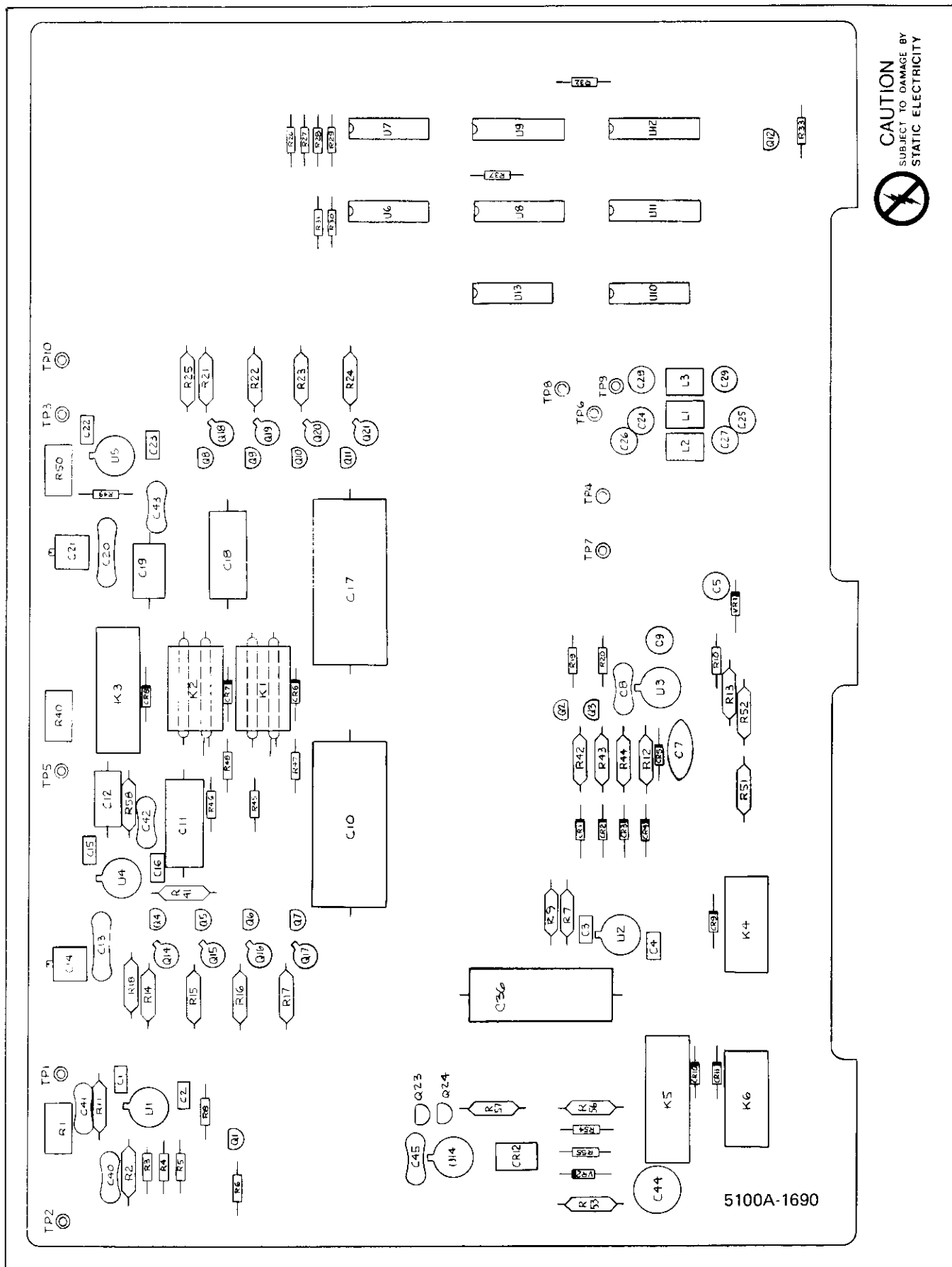

Figure 5-21. A18 Oscillator PCB Assembly

Table 5-28. A19 Isolator PCB Assembly

REF DES	DESCRIPTION	FLUKE STOCK NO.	MFG SPLY CODE	MFG PART NO. OR TYPE	TOT QTY	REC QTY	NO TE
A19	⊗ ISOLATOR PCB ASSEMBLY FIGURE 5-22 (MIS-4181)	383877	89536	383877	REF		
C1	CAP, MICA, 220 PF +/-5%, 500V	170423	72136	DM15F221J	2		
C2	CAP, MICA, 18 PF +/-5%, 500V	266585	72136	DM15C180J	1		
C3	CAP, MICA, 180 PF +/-5%, 500V	148460	72136	DM15F181J	1		
C4	CAP, MICA, 220 PF +/-5%, 500V	170423	72136	DM15F221J	REF		
C5	CAP, MICA, 68 PF +/-5%, 500V	148510	72136	DM15F680J	1		
C6	CAP, TA, 39 UF +/-20%, 6V	163915	56289	196D396X0006KA1	1		
C7	CAP, ELECT, 150 UF -10/+50%, 16V	186296	73445	ET151X016A5	1	1	
C8	CAP, MICA, 27 PF +/-5%, 500V	177998	72136	DM15E270J	2		
C9	CAP, MICA, 27 PF +/-5%, 500V	177998	72136	DM15E270J	REF		
C10	CAP, CER, 0.22 UF +/-20%, 50V	309849	71590	CW30C224K	3		
C11	CAP, CER, 0.0047 UF +/-10%, 500V	106724	71590	CF-472	1		
C12	CAP, CER, 0.22 UF +/-20%, 50V	309849	71590	CW30C224K	REF		
C13	CAP, CER, 0.22 UF +/-20%, 50V	309849	71590	CW30C224K	REF		
H1	SCREW, PHP, 4-40 X 5/8 (NOT SHOWN)	145813	73734	19027	2		
MP1	SPRING, COIL (NOT SHOWN)	424465	83553	CO120-014-0380	2		
Q1	XSTR, SI, PNP	226290	04713	MPS3640	1	1	
R1	RES, COMP, 220 +/-5%, 1/4W	147959	01121	CB2215	1		
R2	RES, COMP, 10K +/-5%, 1/4W	148106	01121	CB1035	8		
R3	RES, COMP, 47K +/-5%, 1/4W	148163	01121	CB4735	1		
R4	RES, COMP, 4.7K +/-5%, 1/4W	148072	01121	CB4725	2		
R5	RES, COMP, 10K +/-5%, 1/4W	148106	01121	CB1035	REF		
R6	RES, COMP, 1K +/-5%, 1/4W	148023	01121	CB1025	1		
R7	RES, COMP, 4.7K +/-5%, 1/4W	148072	01121	CB4725	REF		
R8	RES, COMP, 10K +/-5%, 1/4W	148106	01121	CB1035	REF		
R9	RES, COMP, 10K +/-5%, 1/4W	148106	01121	CB1035	REF		
R10	RES, COMP, 10K +/-5%, 1/4W	148106	01121	CB1035	REF		
R11	RES, COMP, 10K +/-5%, 1/4W	148106	01121	CB1035	REF		
R12	RES, COMP, 10K +/-5%, 1/4W	148106	01121	CB1035	REF		
R13	RES, COMP, 10K +/-5%, 1/4W	148106	01121	CB1035	REF		
R14	RES, COMP, 150 +/-5%, 1/4W	147934	01121	CB1515	1		
R15	RES, COMP, 470 +/-5%, 1/4W	147983	01121	CB4715	1		
T1	INDUCTOR	437608	89536	437608	4		
T2	INDUCTOR	437590	89536	437590	4		
T3	INDUCTOR	437608	89536	437608	REF		
T4	INDUCTOR	437590	89536	437590	REF		
T5	INDUCTOR	437590	89536	437590	REF		
T6	INDUCTOR	437608	89536	437608	REF		
T7	INDUCTOR	437590	89536	437590	REF		
T8	INDUCTOR	437608	89536	437608	REF		
U1	⊗ IC, C-MOS, HEX, BUFFER/INVERTER	381830	02735	CD4050AE	3	1	
U2	⊗ IC, C-MOS, HEX, BUFFER/INVERTER	381830	02735	CD4050AE	REF		
U3	IC, TTL, MSI 8-BIT SHIFT REGISTER	293118	01295	SN74165N	2	1	
U4	IC, TTL, QUAD, 2-IN, HI-VOLT INTRF NAND	408021	18324	N7426A	2	1	
U5	⊗ IC, C-MOS, HEX, BUFFER/INVERTER	381830	02735	CD4050AE	REF		
U6	IC, TTL, POS NAND GATES, HEX, INVERTERS	393058	01295	SN74LS04N	2	1	
U7	IC, TTL, MSI 8-BIT SHIFT REGISTER	293118	01295	SN74165N	REF		
U8	IC, TTL, LO-PWR, SNGL/DUAL RETRIG	404186	01295	SN74LS123N	3	1	

Table 5-28. A19 Isolator PCB Assembly (cont)

REF DES	DESCRIPTION	FLUKE STOCK NO.	MFG SPLY CODE	MFG PART NO. OR TYPE	TOT QTY	REC QTY	N O T E
U9	IC, TTL, QUAD, 2-INPUT, NAND GATE	363580	01295	SN74S00N	1	1	
U10	IC, POS NAND GATES, TRIPLE 3-INPUT	393074	01295	SN74LS10N	1	1	
U11	IC, POS NOR GATES, TOTEM POLE OUTPUTS	393041	01295	SN74LS02N	2	1	
U12	⊗ IC, C-MOS, QUAD, 2-INPUT, NOR GATES	355172	02735	CD4001AE	3	1	
U13	⊗ IC, C-MOS, TRI-STATE, HEX, NONINV BFFRS	407759	12040	MM80C97N	2	1	
U14	IC, TTL, LO-PWR, SNGL/DUAL RETRIG	404186	01295	SN74LS123N	REF		
U15	IC, TTL, QUAD, 2-IN, HI-VOLT INTRE NAND	408021	18324	N7426A	REF		
U16	IC, SHIFT REGISTER, 8-BIT PARALLEL OUT	272138	01295	SN74164N	2	1	
U17	RESISTOR NETWORK, 10K +/-5%, 1/4W	355305	89536	355305	1	1	
U18	⊗ IC, C-MOS, QUAD, 2-INPUT AND GATE	408401	02735	CD4081B1	1	1	
U19	IC, POS NOR GATES, TOTEM POLE OUTPUTS	393041	01295	SN74LS02N	REF		
U20	IC, SHIFT REGISTER, 8-BIT PARALLEL OUT	272138	01295	SN74164N	REF		
U21	⊗ IC, C-MOS, TRI-STATE, HEX, NONINV BFFRS	407759	12040	MM80C97N	REF		
U22	⊗ IC, C-MOS, QUAD, 2-INPUT, NOR GATES	355172	02735	CD4001AE	REF		
U23	IC, TTL, LO-PWR, SNGL/DUAL RETRIG	404186	01295	SN74LS123N	REF		
U24	IC, TTL, POS NAND GATES, HEX, INVERTERS	393058	01295	SN74LS04N	REF		
U25	⊗ IC, C-MOS, TRIPLE 3-INPUT NOR GATES	355180	02735	CD4025AE	1	1	
U26	⊗ IC, C-MOS, QUAD, 2-INPUT, NOR GATES	355172	02735	CD4001AE	REF		

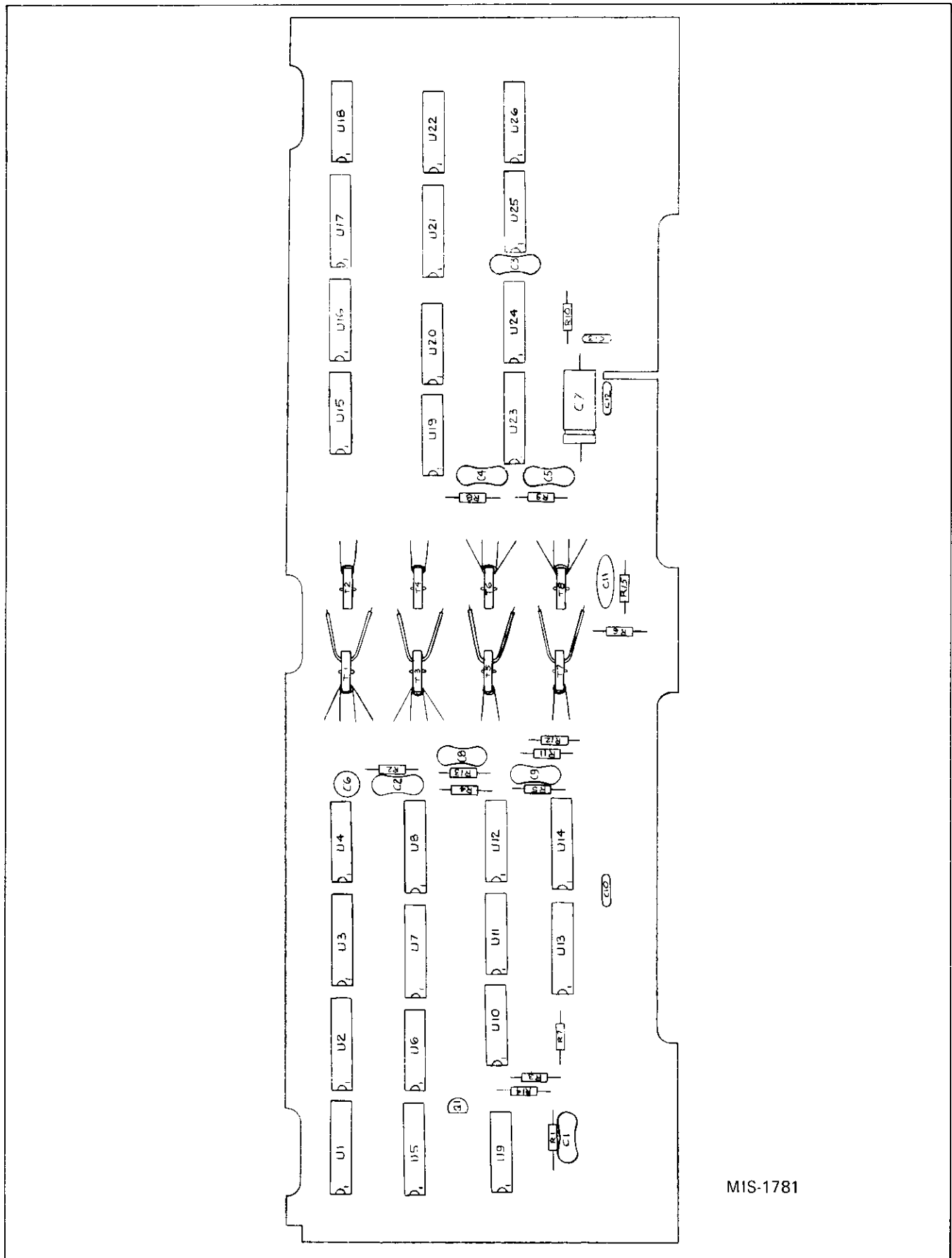

MIS-1781

Figure 5-22. A19 Isolator PCB Assembly

Table 5-29. A20 Controller PCB Assembly

REF DES	DESCRIPTION	FLUKE STOCK NO.	MFG SPLY CODE	MFG PART NO. OR TYPE	TOT QTY	REC QTY	NO TE
A20	CONTROLLER PCB ASSEMBLY FIGURE 5-23 (5100A-4185T)	477083	89536	477083	REF		
C1	CAP, MICA, 22 PF +/-5%, 500V	148551	72136	DM15E220J	1		
C2	CAP, MICA, 47 PF +/-5%, 500V	148536	72136	DM15E470J	1		
C3	CAP, CER, 0.01 UF +/-20%, 100V	407361	72982	8121-A100-W5R-103M	15		
C4	CAP, CER, 0.01 UF +/-20%, 100V	407361	72982	8121-A100-W5R-103M	REF		
C5	CAP, CER, 0.01 UF +/-20%, 100V	407361	72982	8121-A100-W5R-103M	REF		
C6	CAP, CER, 0.047 UF +/-20%, 50V	460733	71590	CW20C473M	1		
C7	CAP, CER, 0.01 UF +/-20%, 100V	407361	72982	8121-A100-W5R-103M	REF		
C8	CAP, MICA, 4 PF +/-0.5 PF, 500V	190397	72136	DM15C040D	2		
C9	CAP, MICA, 4 PF +/-0.5 PF, 500V	190397	72136	DM15C040D	REF		
C10	CAP, CER, 1 UF +/-20%, 50V	436782	51642	300-050-601-105M	1		
C11	CAP, CER, 0.01 UF +/-20%, 100V	407361	72982	8121-A100-W5R-103M	REF		
C12	CAP, CER, 0.01 UF +/-20%, 100V	407361	72982	8121-A100-W5R-103M	REF		
C13	CAP, CER, 0.01 UF +/-20%, 100V	407361	72982	8121-A100-W5R-103M	REF		
C14	CAP, CER, 0.01 UF +/-20%, 100V	407361	72982	8121-A100-W5R-103M	REF		
C15	CAP, CER, 0.01 UF +/-20%, 100V	407361	72982	8121-A100-W5R-103M	REF		
C16	CAP, CER, 0.01 UF +/-20%, 100V	407361	72982	8121-A100-W5R-103M	REF		
C17	CAP, CER, 0.01 UF +/-20%, 100V	407361	72982	8121-A100-W5R-103M	REF		
C18	CAP, TA, 15 UF +/-20%, 6V	161935	56289	196D156X0006JA1	1		
C19	CAP, CER, 0.22 UF +/-20%, 50V	309849	71590	CW30C224K	1		
C20	CAP, CER, 0.01 UF +/-20%, 100V	407361	72982	8121-A100-W5R-103M	REF		
C21	CAP, CER, 0.01 UF +/-20%, 100V	407361	72982	8121-A100-W5R-103M	REF		
C22	CAP, TA, ELECT, 1 UF +/-5%, 15V	461152	56289	150D105X5015A	1		1
C23	CAP, CER, 0.01 UF +/-20%, 100V	407361	72982	8121-A100-W5R-103M	REF		
C24	CAP, MICA, 33 PF +/-5%, 500V	160317	72136	DM15E330J	2		
C25	CAP, TA, 39 UF +/-20%, 6V	163915	56289	196D396X0006KA1	1		
C26	CAP, CER, 2200 PF +/-10%, 500V	268425	72982	851-000-Z5R-222K	1		
C27	CAP, MICA, 33 PF +/-5%, 500V	160317	72136	DM15E330J	REF		
C28	CAP, CER, 0.022 UF -20/+100%, 40V	358325	72982	8121,A050-651-223Z	1		
C29	CAP, TA, 2.2 UF +/-20%, 20V	161927	56289	196D2225X0020HA1	3		
C30	CAP, TA, 2.2 UF +/-20%, 20V	161927	56289	196D2225X0020HA1	REF		
C31	CAP, TA, 2.2 UF +/-20%, 20V	161927	56289	196D2225X0020HA1	REF		
C32	CAP, CER, 0.01 UF +/-20%, 100V	407361	72982	8121-A100-W5R-103M	REF		
C33	CAP, TA, 1500 UF +/-20%, 6V	460204	56289	183DR157X0006F	1		
CR1	DIODE, SI, HI-SPEED SWITCHING	203323	07910	IN4448	1		1
H1	SCREW, PHP, 4-40 X 3/8	256164	89536	256164	1		
J1	SOCKET, IC, 9-PIN	436774	30035	SS-109-1-09	1		
MP1	SPRING, COL	424465	83553	C-0120-014-0380	1		
MP2	DECAL	453589	89536	453589	1		
R1	RES, VAR, CERMET, 10K +/-10%, 1/2W	285171	89536	285171	1		1
R2	RES, COMP, 100K +/-5%, 1/4W	148189	01121	CB1045	3		
R3	RES, COMP, 4.7K +/-5%, 1/4W	148072	01121	CB4725	6		
R4	RES, COMP, 2K +/-5%, 1/4W	202879	01121	CB2025	4		
R5	RES, COMP, 6.8K +/-5%, 1/4W	148098	01121	CB6825	2		
R6	RES, COMP, 10M +/-5%, 1/4W	194944	01121	CB1065	1		
R7	RES, COMP, 2K +/-5%, 1/4W	202879	01121	CB2025	REF		
R8	RES, COMP, 4.7K +/-5%, 1/4W	148072	01121	CB4725	REF		
R9	RES, COMP, 4.7K +/-5%, 1/4W	148072	01121	CB4725	REF		

Table 5-29. A20 Controller PCB Assembly (cont)

REF DES	DESCRIPTION	FLUKE STOCK NO.	MFG SPLY CODE	MFG PART NO. OR TYPE	TOT QTY	REC QTY	NOTE
R10	RES, COMP, 4.7K +/-5%, 1/4W	148072	01121	CB4725	REF		
R11	RES, COMP, 4.7K +/-5%, 1/4W	148072	01121	CB4725	REF		
R12	RES, COMP, 10K +/-5%, 1/4	148106	01121	CB1035	2		
R13	RES, COMP, 10K +/-5%, 1/4	148106	01121	CB1035	REF		
R14	RES, MTL. FILM, 715 +/-1%, 1/8W	313080	91637	CMF557150F	1		
R15	RES, MTL. FILM, 523 +/-1%, 1/8W	294835	91637	CMF555320F	1		
R16	RES, COMP, 4.7K +/-5%, 1/4W	148072	01121	CB4725	REF		
R17	RES, MTL. FILM, 4.99K +/-1%, 1/8W	168252	91637	CMF554991F	1		
R18	RES, MTL. FILM, 23.2K +/-1%, 1/8W	291351	91637	CMF552322F	1		
R19	RES, COMP, 2K +/-5%, 1/4W	202879	01121	CB2025	REF		
R20	RES, COMP, 10K +/-5%, 1/4	148106	01121	CB1035	REF		
R21	RES, COMP, 6.8K +/-5%, 1/4W	148098	01121	CB6825	REF		
R22	RES, COMP, 3K +/-5%, 1/4W	193508	01121	CB3025	1		
R23	RES, COMP, 680K +/-5%, 1/4W	188433	01121	CB6845	1		
R24	RES, COMP, 1.5K +/-5%, 1/4W	148031	01121	CB1525	1		
R25	RES, COMP, 100K +/-5%, 1/4W	148189	01121	CB1045	REF		
R26	RES, COMP, 30K +/-5%, 1/4W	193417	01121	CB3035	1		
R27	RES, COMP, 2K +/-5%, 1/4W	202879	01121	CB2025	REF		
R28	RES, COMP, 100K +/-5%, 1/4W	148189	01121	CB1045	REF		
RN1	RESISTOR NETWORK, 4.7K +/-2%, 1/8W	412916	89536	412916	2		
RN2	RESISTOR NETWORK, 4.7K +/-2%, 1/8W	412916	89536	412916	REF		
RN3	RESISTOR NETWORK, 10K +/-2%, 1/8W	412924	89536	412924	1	1	
U1	IC, TTL, LO-PWR DUAL-J-K, F/F	412999	01295	SN74LS109N	1	1	
U2⊗	IC, C-MOS, HEX, BUFFER/INVERTERS	381830	02735	CD4050AE	1	1	
U3⊗	IC, C-MOS, NAND GATE	413211	07263	34011PC/4011PC	1	1	
U5⊗	IC, MOS, 1024 BIT	404558	01295	TMS4042-INL	4		
U6⊗	IC, MOS, 1024 BIT	404558	01295	TMS4042-INL	REF		
U8	IC, TTL, AND-OR-INVERTER GATES TOTEM OUT	412981	01295	SN74LS51N	1	1	
U9⊗	IC, C-MOS, HEX, INVERTER	404699	12040	MM74C04N	1	1	
U10⊗	IC, MOS, MICROPROCESSER	404541	34649	C8080A	1	1	
U12⊗	IC, MOS, 1024 BIT	404558	01295	TMS4042-INL	REF		
U13⊗	IC, MOS, 1024 BIT	404558	01295	TMS4042-INL	REF		
U14⊗	IC, C-MOS, DUAL, "D"-TYPE, F/F	340117	02735	CD4013AE	2	1	
U15	IC, TTL, QUAD, 2-INPUT, POS AND GATES	393066	01295	SN74LS08N	1	1	
U16	IC, TTL, POS NAND GATES, HEX, INVERTER	393058	01295	SN74LS04N	2	1	
U17⊗	IC, C-MOS, NAND GATES, TRIPLE, 3-INPUT	375147	02735	CD4023AE	1	1	
U18	IC, TTL, LO-PWR, HEX, QUAD, "D"-TYPE F/F	393207	01295	SN74LS174N	1	1	
U19⊗	IC, C-MOS, MSI STRUBED, HEX INVT/BUFFER	408211	04713	MC14502CP	2	1	
U20	IC, TTL, MSI, DECOD DEMULT	393165	01295	SN74LS139N	1	1	
U21	IC, TTL, POS NAND GATES, HEX, INVERTER	393058	01295	SN74LS04N	REF		
U23⊗	IC, C-MOS, TRI-STATE HEX, NON INV/BUFF	407759	12040	MM80C97N	3	1	
U24⊗	IC, C-MOS, TRI-STATE HEX, NON INV/BUFF	407759	12040	MM80C97N	REF		
U26⊗	IC, LIN, C-MOS, PHASE LOCKED LOOP	403584	02735	CD4046AE	1	1	
U27⊗	IC, C-MOS, QUAD, 2-INPUT OF GATE	408393	02735	CD4071BE	1	1	
U28⊗	IC, C-MOS, 8-BIT, PRIORITY ENCODER	412973	02735	CD4532BE	1	1	
U29⊗	IC, C-MOS, MSI STRUBED, HEX INVT/BUFFER	408211	04713	MC14502CP	REF		
U30⊗	IC, C-MOS, TRI-STATE HEX, NON INV/BUFF	407759	12040	MM80C97N	REF		
U31	IC, TTL, POS NAND GATES, TRIPLE, 3-INPUT	393074	01295	SN74LS10N	1	1	
U32⊗	IC, C-MOS, HEX, INVERTER	404681	02735	CD4069BE	1	1	
U34⊗	IC, C-MOS, DUAL UP COUNTER	355164	04713	MC14520CL/CP	1	1	

Table 5-29. A20 Controller PCB Assembly (cont)

REF DES	DESCRIPTION	FLUKE STOCK NO.	MFG SPLY CODE	MFG PART NO. OR TYPE	TOT QTY	REC QTY	N O T E
U35Ⓞ	IC, C-MOS, DUAL, "D"-TYPE, F/F	340117	02735	CD4013AE	REF		
U36Ⓞ	IC, C-MOS, RETRG/RESET, MONO/MULTI	454017	04713	MC14538BCP	1	1	
U37Ⓞ	IC, C-MOS, NOR GATES, QUAD, 2-INPUT	429944	02735	CD4001BE	1	1	
U38Ⓞ	IC, C-MOS, QUAD, 2-INPUT NAND SMITT/TR	404632	02735	CD4093BE	1		
WT1	TIE, CABLE, NYLON	172080	06383	SST-1M	1		
XU4	SOCKET, IC, 18-PIN	418228	91506	318-AG39D	6		
XU5	SOCKET, IC, 18-PIN	418228	91506	318-AG39D	REF		
XU6	SOCKET, IC, 18-PIN	418228	91506	318-AG39D	REF		
XU10	SOCKET, IC 40-PIN	418988	91506	340-AG39D	1		
XU11	SOCKET, IC, 18-PIN	418228	91506	318-AG39D	REF		
XU12	SOCKET, IC, 18-PIN	418228	91506	318-AG39D	REF		
XU13	SOCKET, IC, 18-PIN	418228	91506	318-AG39D	REF		
XU25	SOCKET, SINGLE LINE, 12-PIN	417733	30035	SS-109-1-12	2		
Y1	CRYSTAL, QUARTZ, 1.70 MHZ	412932	89536	412932	1		

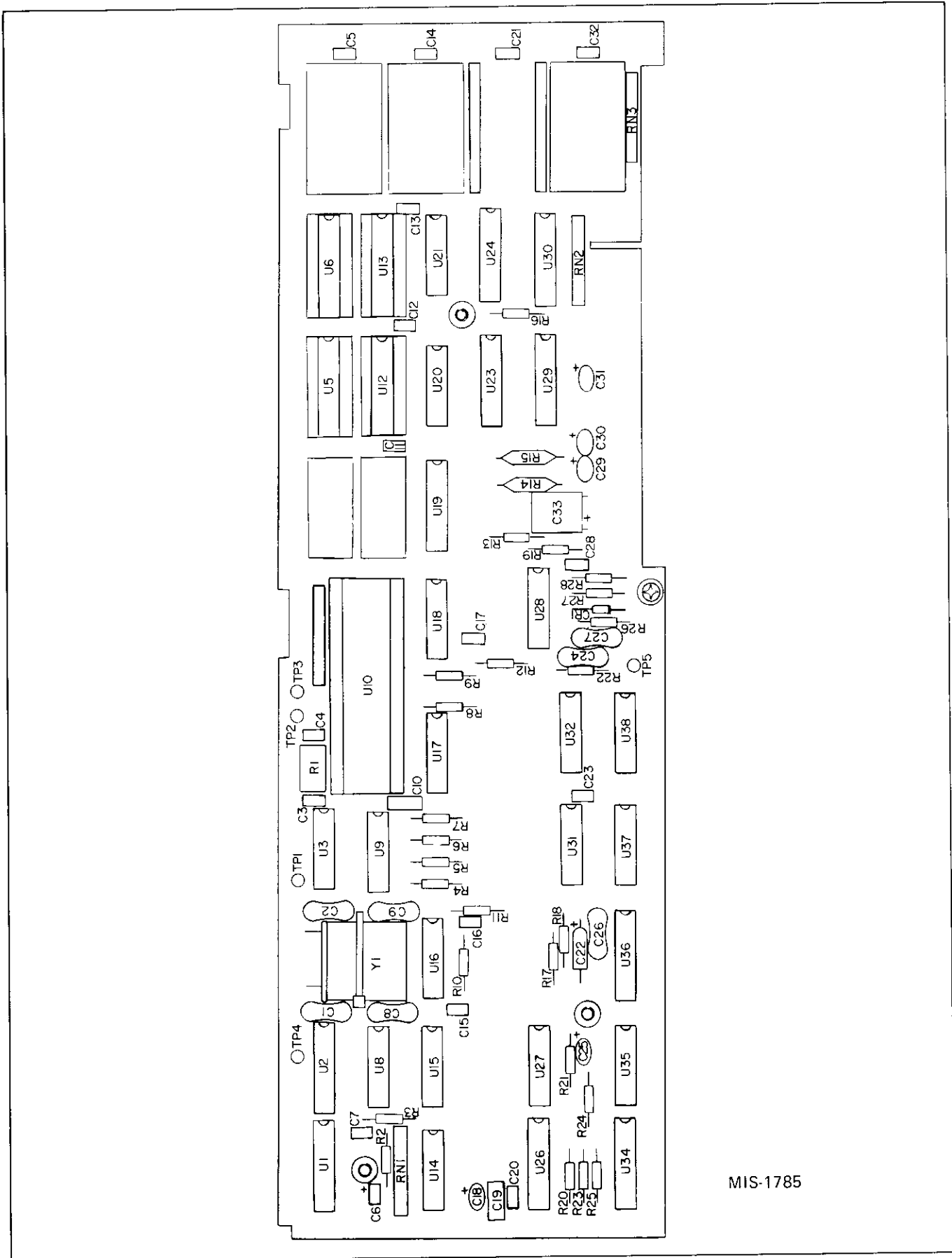

MIS-1785

Figure 5-23. A20 Controller PCB Assembly

Table 5-30. A21 PROM-ROM-RAM PCB Assembly, Non-Storage

REF DES	DESCRIPTION	FLUKE STOCK NO.	MFG SPLY CODE	MFG PART NO. OR TYPE	TOT QTY	REC QTY	NOTE
A21	PROM-ROM-RAM PCB ASSEMBLY FIGURE 5-24 (5100A-4088T) USED ON 5100B AND 5102B (NON-STORAGE)	522821	89536	522821			REF
C1	CAP, CER, 0.01 UF +/-20%, 100V	407361	72982	8121-A100-W5R-103M	2		
C2	CAP, CER, 0.01 UF +/-20%, 100V	407361	72982	8121-A100-W5R-103M			REF
C3	CAP, CER, 0.22 UF +/-20%, 50V	309849	71590	CW30C224K	13		
C4	CAP, CER, 0.22 UF +/-20%, 50V	309849	71590	CW30C224K			REF
C5	CAP, CER, 0.22 UF +/-20%, 50V	309849	71590	CW30C224K			REF
C6	CAP, CER, 0.22 UF +/-20%, 50V	309849	71590	CW30C224K			REF
C7	CAP, CER, 0.22 UF +/-20%, 50V	309849	71590	CW30C224K			REF
C8	CAP, CER, 0.22 UF +/-20%, 50V	309849	71590	CW30C224K			REF
C9	CAP, CER, 0.22 UF +/-20%, 50V	309849	71590	CW30C224K			REF
C11	CAP, CER, 0.22 UF +/-20%, 50V	309849	71590	CW30C224K			REF
C12	CAP, CER, 0.22 UF +/-20%, 50V	309849	71590	CW30C224K			REF
C13	CAP, CER, 0.22 UF +/-20%, 50V	309849	71590	CW30C224K			REF
C14	CAP, CER, 0.22 UF +/-20%, 50V	309849	71590	CW30C224K			REF
C15	CAP, CER, 0.22 UF +/-20%, 50V	309849	71590	CW30C224K			REF
C16	CAP, CER, 0.22 UF +/-20%, 50V	309849	71590	CW30C224K			REF
C17	CAP, TA, 5.6 UF +/-20%, 25V	368969	56289	196D565X0025KA1	1		
C18	CAP, TA, 2.2 UF +/-20%, 15V	161927	56289	196D225X0015HA1	1		
H1	WASHER	187989	89536	187989	6		
MP1	DECAL (522821)	524090	89536	524090	1		
P1	CONNECTOR, 36-PIN	447813	22526	65501-136	2		
P2	CONNECTOR, 36-PIN	447813	22526	65501-136			REF
R1	RES, DEP CAR, 10K +/-5%, 1/4W	348839	80031	CR251-4-5-10KT	1		
U1	IC, TTL, LO-PWR, 3-8 LINE DECODER	407585	01295	SN74LS138N	2		
U2	IC, TTL, LO-PWR, 3-8 LINE DECODER	407585	01295	SN74LS138N			REF
U3	IC, ROM, 5101B-8021	523936	89536	523936	1		
U4	IC, ROM, 5101B-8022	523944	89536	523944	1		
U5	IC, ROM, 5101B-8023	523951	89536	523951	1		
U6	IC, ROM, 5101B-8024	523969	89536	523969	1		
U7	IC, ROM, 5101B-8025	523977	89536	523977	1		
U17⊗	IC, CMOS, TRI-STATE HEX, NON-INV BUFF	407759	12040	MM80C97N	3		
U18⊗	IC, CMOS, TRI-STATE HEX, NON-INV BUFF	407759	12040	MM80C97N			REF
U19⊗	IC, CMOS, TRI-STATE HEX, NON-INV BUFF	407759	12040	MM80C97N			REF
U20	IC, TTL, QUAD, 2-IN POS AND GATE	393066	01295	SN74LS08N	1		
U21	IC, TTL, QUAD, 2-IN POS OR GAT ²	393108	01295	SN74LS32N	1		
XU3	SOCKET, COMP, LEAD	376418	22526	75060-007	228		
XU4	SOCKET, 24-PIN	376236	91506	324-AG39D	3		
XU5	SOCKET, 24-PIN	376236	91506	324-AG39D			REF
XU6	SOCKET, 24-PIN	376236	91506	324-AG39D			REF
XU7	SOCKET, COMP, LEAD	376418	22526	75060-007			REF
XU8	SOCKET, COMP, LEAD	376418	22526	75060-007			REF
XU9	SOCKET, COMP, LEAD	376418	22526	75060-007			REF
XU10	SOCKET, COMP, LEAD	376418	22526	75060-007			REF
XU11	SOCKET, COMP, LEAD	376418	22526	75060-007			REF
XU12	SOCKET, COMP, LEAD	376418	22526	75060-007			REF
XU13	SOCKET, COMP, LEAD	376418	22526	75060-007			REF
XU14	SOCKET, COMP, LEAD	376418	22526	75060-007			REF
XU15	SOCKET, COMP, LEAD	376418	22526	75060-007			REF
XU16	SOCKET, COMP, LEAD	376418	22526	75060-007			REF

Table 5-31. A21 PROM-ROM-RAM PCB Assembly, Storage

REF DES	DESCRIPTION	FLUKE STOCK NO.	MFG SPLY CODE	MFG PART NO. OR TYPE	TOT QTY	REC QTY	NOTE
A21	PROM-ROM-RAM PCB ASSEMBLY FIGURE 5-24 (5101B-4088T) USED ON 5101B (STORAGE)	522854	89536	522854		REF	
C1	CAP, CER, 0.01 UF +/-20%, 100V	407361	72982	8121-A100-W5R-103M	2		
C2	CAP, CER, 0.01 UF +/-20%, 100V	407361	72982	8121-A100-W5R-103M		REF	
C3	CAP, CER, 0.22 UF +/-20%, 50V	309849	71590	CW30C224K	13		
C4	CAP, CER, 0.22 UF +/-20%, 50V	309849	71590	CW30C224K		REF	
C5	CAP, CER, 0.22 UF +/-20%, 50V	309849	71590	CW30C224K		REF	
C6	CAP, CER, 0.22 UF +/-20%, 50V	309849	71590	CW30C224K		REF	
C7	CAP, CER, 0.22 UF +/-20%, 50V	309849	71590	CW30C224K		REF	
C8	CAP, CER, 0.22 UF +/-20%, 50V	309849	71590	CW30C224K		REF	
C9	CAP, CER, 0.22 UF +/-20%, 50V	309849	71590	CW30C224K		REF	
C11	CAP, CER, 0.22 UF +/-20%, 50V	309849	71590	CW30C224K		REF	
C12	CAP, CER, 0.22 UF +/-20%, 50V	309849	71590	CW30C224K		REF	
C13	CAP, CER, 0.22 UF +/-20%, 50V	309849	71590	CW30C224K		REF	
C14	CAP, CER, 0.22 UF +/-20%, 50V	309849	71590	CW30C224K		REF	
C15	CAP, CER, 0.22 UF +/-20%, 50V	309849	71590	CW30C224K		REF	
C16	CAP, CER, 0.22 UF +/-20%, 50V	309849	71590	CW30C224K		REF	
C17	CAP, TA, 5.6 UF +/-20%, 25V	368969	56289	196D565X0025KA1	1		
C18	CAP, TA, 2.2 UF +/-20%, 15V	161927	56289	196D225X0015HA1	1		
H1	WASHER	187989	89536	187989	6		
MP1	DECAL (522854)	524108	89536	524108	1		
P1	CONNECTOR, 36-PIN	447813	22526	65501-136	2		
P2	CONNECTOR, 36-PIN	447813	22526	65501-136		REF	
R1	RES, DEP CAR, 10K +/-5%, 1/4W	348839	80031	CR251-4-5-10KT	1		
U1	IC, TTL, LO-PWR, 3-8 LINE DECODER	407585	01295	SN74LS138N	2		
U2	IC, TTL, LO-PWR, 3-8 LINE DECODER	407585	01295	SN74LS138N		REF	
U3	IC, ROM, 5101B-8021	523936	89536	523936	1		
U4	IC, ROM, 5101B-8022	523944	89536	523944	1		
U5	IC, ROM, 5101B-8023	523951	89536	523951	1		
U6	IC, ROM, 5101B-8024	523969	89536	523969	1		
U7	IC, ROM, 5101B-8025	523977	89536	523977	1		
U8	IC, ROM, 5101B-8026	523985	89536	523985	1		
U9	IC, ROM, 5101B-8027	523993	89536	523993	1		
U11⊗	IC, MOS, N-CHANNEL	453506	34649	P2114	6		
U12⊗	IC, MOS, N-CHANNEL	453506	34649	P2114		REF	
U13⊗	IC, MOS, N-CHANNEL	453506	34649	P2114		REF	
U14⊗	IC, MOS, N-CHANNEL	453506	34649	P2114		REF	
U15⊗	IC, MOS, N-CHANNEL	453506	34649	P2114		REF	
U16⊗	IC, MOS, N-CHANNEL	453506	34649	P2114		REF	
U17⊗	IC, C-MOS, TRI-ST HEX, NON-INV BUFFR	407759	12040	MM80C97N	3		
U18⊗	IC, C-MOS, TRI-ST HEX, NON-INV BUFFR	407759	12040	MM80C97N		REF	
U19⊗	IC, C-MOS, TRI-ST HEX, NON-INV BUFFR	407759	12040	MM80C97N		REF	
U20	IC, TTL, QUAD, 2-IN POS AND GATE	393066	01295	SN74LS08N	1		
U21	IC, TTL, QUAD, 2-IN POS OR GATE	393108	01295	SN74LS32N	1		
XU3	SOCKET, COMP, LEAD	376418	22526	75060-007	228		
XU4	SOCKET, 24-PIN	376236	91506	324-AG39D	3		

Table 5-31. A21 PROM-ROM-RAM PCB Assembly, Storage (cont)

REF DES	DESCRIPTION	FLUKE STOCK NO.	MFG SPLY CODE	MFG PART NO. OR TYPE	TOT QTY	REC QTY	N O T E
XU5	SOCKET, 24-PIN	376236	91506	324-AG39D		REF	
XU6	SOCKET, 24-PIN	376236	91506	324-AG39D		REF	
XU7	SOCKET, COMP, LEAD	376418	22526	75060-007		REF	
XU8	SOCKET, COMP, LEAD	376418	22526	75060-007		REF	
XU9	SOCKET, COMP, LEAD	376418	22526	75060-007		REF	
XU10	SOCKET, COMP, LEAD	376418	22526	75060-007		REF	
XU11	SOCKET, COMP, LEAD	376418	22526	75060-007		REF	
XU12	SOCKET, COMP, LEAD	376418	22526	75060-007		REF	
XU13	SOCKET, COMP, LEAD	376418	22526	75060-007		REF	
XU14	SOCKET, COMP, LEAD	376418	22526	75060-007		REF	
XU15	SOCKET, COMP, LEAD	376418	22526	75060-007		REF	
XU16	SOCKET, COMP, LEAD	376418	22526	75060-007		REF	

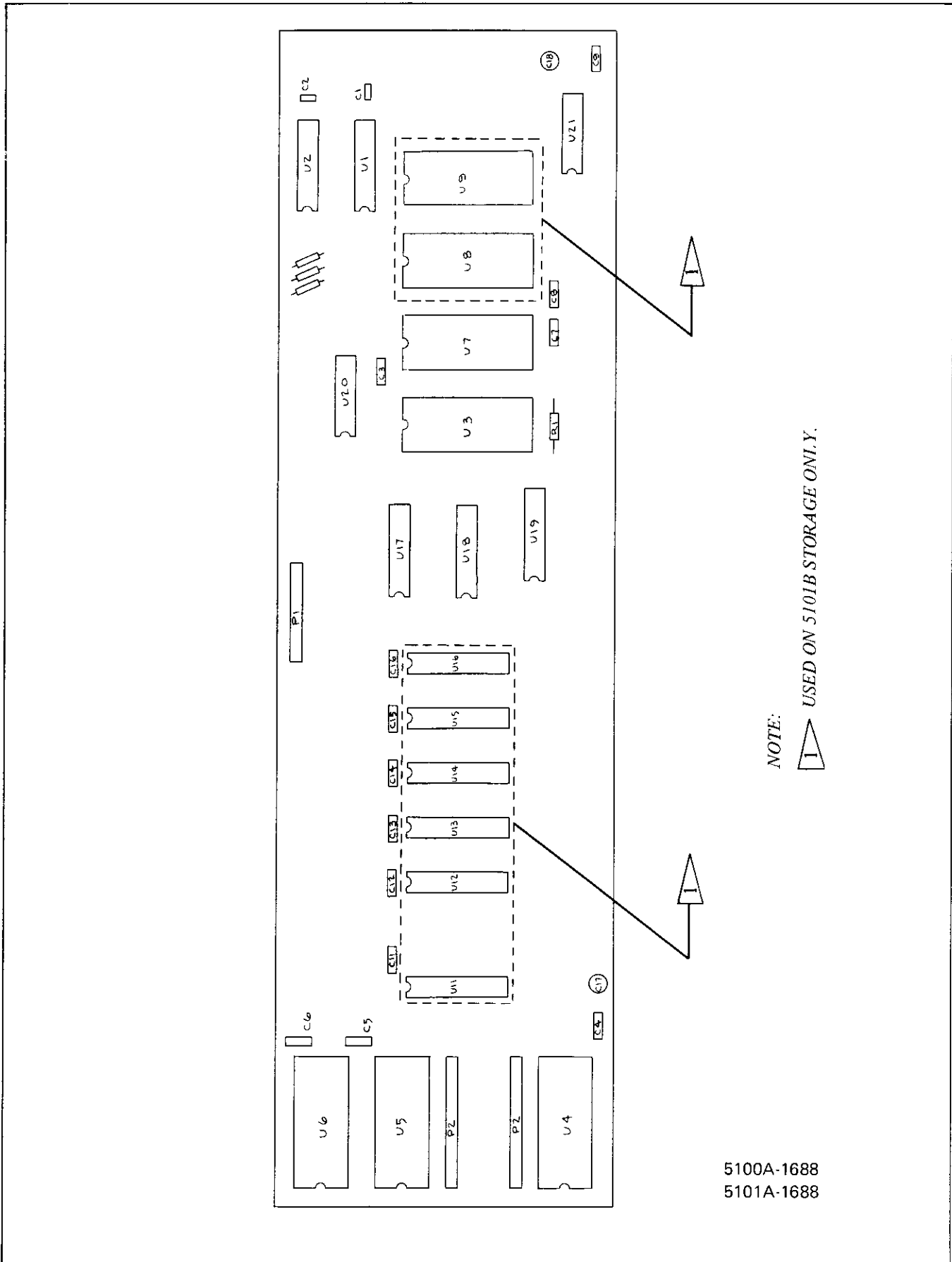

Figure 5-24. A21 PROM-ROM-RAM PCB Assembly

Section 6

Option & Accessory Information

TABLE OF CONTENTS

OPTION/ MODEL NO.	DESCRIPTION	PAGE
ACCESSORIES		
5100A-7003K	Transit Case	600-1
5100A-7005K	PCB and Cable Extender Assembly Kit	600-1
M1S-7190K	Static Controller	600-1
M08-205-600	Rack Mounting Kit	600-1
Y5000	5100 Series Interface	600-1
Y5001	Interface Cable Assembly	600-2
Y5002	Interface Cable Assembly	600-2
Y8005	IEEE-488 Printer (Storage Only)	600-2
Y8006	Bit-Serial Interface (RS-232-C) Printer (Storage Only)	600-2
Y8001	Printer Cables IEEE (Storage Only)	600-3
Y8002	Printer Cables IEEE (Storage Only)	600-3
Y8003	Printer Cables IEEE (Storage Only)	600-3
Y8004	Printer Cables RS-232-C(Storage Only)	600-3
OPTIONS		
-03	Wideband Frequency	603-1
-05	IEEE-488-1975	605-1
-06	Bit Serial Asynchronous Interface (RS-232-C)	606-1

6-1. INTRODUCTION

6-2. This section of the manual contains information on the accessories and options available for the 5100 Series B Calibrators.

6-3. ACCESSORY INFORMATION

6-4. The portion of this section dealing with accessories will contain the details of all accessories available for the 5100 Series B.

6-5. OPTION INFORMATION

6-6. Each of the options available for the 5100 Series B are described separately in a sub-section identified with the option name and number. The option description contains the information on the operating instructions and maintenance not covered in the main body of the text, plus a complete list of replaceable parts for the option.

Accessories

600-1. TRANSIT CASE 5100A-7003K

600-2. This kit contains a case designed to protect the 5100B and 5101B Calibrators while the instrument is in transit. The bottom portion of the case is two inches high, permitting the operator access to the instrument controls when the top cover is removed. This removes the necessity of lifting the instrument from the case and lessens the possibility of damage in transit. The transit case is illustrated in Figure 600-1.

600-3. PCB AND CABLE EXTENDER ASSEMBLY KIT, 5100A-7005K

600-4. This kit contains the extender cables and PCBs required for servicing the instrument. Component parts of the kit are listed in Table 600-1. Replacement items for the kit can be ordered using the FLUKE Stock Number in the Table and the procedure in Section 5.

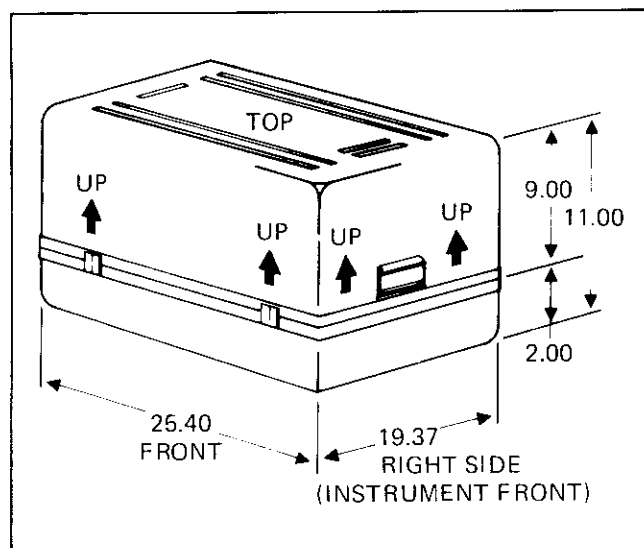

Figure 600-1. Transit Case

Table 600-1. Extender Kit

DESCRIPTION	FLUKE STOCK NO.
Analog Extender PCB	420323
Digital (MIS) Extender PCB	455758

600-5. STATIC CONTROLLER MIS-7190K

600-6. Replaces the Controller PCB in the digital compartment providing the operator switch control of the data and control lines. Operation of the Static Controller is covered in the manual that comes with the device.

600-7. RACK MOUNTING KIT M08-205-600

600-8. Instructions for the use and installation of the rack mounting mounting accessory accompany the kit.

600-9. CHASSIS SLIDES KIT M00-280-610

600-10. Instructions for the installation and use of the chassis slides accessory accompany the kit.

600-11. Y5000 5100 SERIES INTERFACE

600-12. The Model Y5000 is a accessory that allows the calibrator operator to slave a Fluke Model 5205A/5215A Power Amplifier and/or a Fluke Model 5220A Transconductance Amplifier to the calibrator to extend the voltage (power) and or current limits of the instrument. Either the 5205A or 5215A may be used as a power amplifier. Operation is the same except that DC output cannot be obtained from the 5215A. Each amplifier must be connected to the interface with a dedicated cable assembly accessory designed specifically for that instrument combination. The cable accessories available are listed in subsequent paragraphs.

600-13. The accessory is a small box that mounts on the rear of the 5100 Series B calibrator. The front has two connectors that mate with the MIS Bus (Digital) Connector and Analog Bus Connector on the calibrator rear panel. It can be securely attached to the calibrator using the screws included with the assembly. The rear of the assembly has two digital (J1 and J3) and two analog (J2 and J4) connectors to provide simultaneous connection to two separate instruments.

600-14. For a description of the Y5000 Interface and further instructions on the installation and use refer to the instruction manual shipped with the accessory.

600-15. Y5001 INTERFACE CABLE ASSEMBLY

600-16. The Y5001 accessory is a dedicated cable assembly that connects a Fluke Model 5205A/5215A Power Amplifier to the Y5000 5100 Series Interface. It consists of a custom-built cable with a male 36-pin connector and a male 14-pin connector on one end to connect to the digital analog outputs, on the Y5000, respectively, and a female 25-pin connector on the other to mate with the connector labeled 5200 on the 5205A or 5215A rear panel.

CAUTION

Do not connect the analog and digital connectors on the Y5001 Cable Assembly directly to the 5100 Calibrator. They must be connected through the Y5000 Interface or damage may result to the calibrator.

600-17. For a description of the Y5001 Cable Assembly and further instructions on installation, refer to the instruction sheet shipped with the assembly.

600-18. Y5002 INTERFACE CABLE ASSEMBLY

600-19. The Y5002 accessory is a dedicated cable assembly that connects a Fluke Model 5220A Transconductance Amplifier to the Y5000 5100 Series Interface. It consists of a custom-built cable with a male 36-pin connector and a male 14-pin connector on one end to connect to the digital and analog outputs, on the Y5000, respectively, and a male 24-pin connector on the other to mate with the connector labeled P71 on the 5220A rear panel.

CAUTION

Do not connect the analog and digital connectors on the Y5002 directly to the 5100 Calibrator. They must be connected through the Y5000 Interface or damage may result to the calibrator.

600-20. For a description of the Y5002 Cable Assembly and further instructions on installation refer to the instruction sheet shipped with the assembly.

600-21. Y8005 IEEE-488 PRINTER (STORAGE ONLY)

600-22. Description

600-23. A hard copy listing of the program and data of storage model calibrators can be obtained with the printer accessory. The listing is printed on 8½ inch width paper with variable lengths. For operation, the printer requires installation of the -05 IEEE-488 Remote Interface Option in the calibrator and the availability of one of the three accessory IEEE-488 Interface Cables listed below.

600-24. Specifications

Printing Speed: Up to 60 characters per second

Copy Size: 21.6 x 27.9 cm (8.5 x 11.0 in) or
21.6 x 14.8 cm (8.5 x 5.8 in)

Operating Power (100V to 240V ±10%; 50-60 Hz):
150W maximum

Dimensions: 19 cm H x 47 cm L x 48 cm W
(7.5 in H x 18.5 in L x 19 in W)

600-25. Y8006 BIT-SERIAL INTERFACE (RS-232-C) PRINTER (STORAGE ONLY)

600-26. Description

600-27. A hard copy listing of the program stored in the instrument's data storage or of the present output of the instrument can be obtained with the printer accessory. Operation of the printer requires installation of the -06 Bit Serial Asynchronous Remote Interface Option in the calibrator and the availability of the RS-232-C Accessory Interface Cable listed below.

600-28. Specifications

Printing Speed: Up to 60 characters per second

Copy Size: 21.6 x 27.9 cm (8.5 x 11.0 in) or
21.6 x 14.8 cm (8.5 x 5.8 in)

Operating Power (100V to 240V ±10%; 50-60 Hz):
150W maximum

Dimensions: 19 cm H x 47 cm L x 48 cm W
(7.5 in H x 18.5 in L x 19 in W)

Weight: 25 kgm (55 lbs)

**600-29. PRINTER CABLES
(STORAGE ONLY)**

600-30. A cable applicable to the accessory printer in use in the system should be selected from Table 600-2. The cable connects the accessory printer to the applicable remote interface at the rear panel.

Table 600-2. Printer Cables

ACCESSORY NO.	INTERFACE TYPE	LENGTH
Y8001	IEEE	1 meter
Y8002	IEEE	2 meters
Y8003	IEEE	4 meters
Y8004	RS-232-C	1.5 meters

**600-31. Y8007 TAPE CASSETTES
(STORAGE ONLY)**

600-32. A pack of eight, blank, mini-cassettes for use with the tape storage system are available as accessory Y8007.

CAUTION

Tapes used must be certified digital mini-cassettes that conform with ANSI standard X3B5/77-49. Audio quality tapes will not give acceptable results.



-03 Option Wideband Frequency

603-1. INTRODUCTION

603-2. The Wideband (WB) Frequency Option increases the frequency capability of the 5100 Series B Calibrators from the standard 50 Hz-50 kHz to 10 Hz-10 MHz. The output voltage is limited to between 300 μ V (-57.5 dB) and 3.1623V ac rms (+23 dB) into 50 ohms with an output impedance of 50 ohms from the options dedicated BNC connector.

603-3. SPECIFICATIONS

603-4. Specifications for the wideband option are included with the instrument specifications in Section 1. A chart showing the additional attenuation for output cables in excess of one (1) foot is included in Table 603-1.

603-5. INSTALLATION

603-6. The option may be installed at any time by inserting the option's two PCB assemblies into the applicable slots in the analog compartment and connecting the cables included.

603-7. OPERATING FEATURES

603-8. The control connector for this option is installed in all instruments; however, they do not operate until the optional PCB assemblies are installed.

603-9. The option is activated when the WIDEBAND switch in the Data Entry Group is toggled.

603-10. While activated all AC voltage outputs must be taken from the Wideband BNC connector output and the maximum voltage available is 3.1623V rms into 50 Ω .

603-11. OPERATING NOTES

603-12. Operation of the instrument for an AC voltage output with the wideband option installed is basically the same as with the standard calibrator. Before operation can begin the WIDEBAND function must be selected with the keyswitch or through a Remote Interface. The WIDEBAND indicator illuminated signals this has been done. The other major change is the requirement that all outputs must be taken from the dedicated 50 ohm output impedance wideband BNC connector.

Table 603-1. Additional Attenuation in dB and Percent for Additional Cable Length

Total Cable Length (1 Ft Std)	Frequency									
	100 KHz		500 KHz		1 MHz		5 MHz		10 MHz	
	dB	%	dB	%	dB	%	dB	%	dB	%
2 ft	0.0014	0.016	0.0025	0.029	0.0035	0.04	0.009	0.104	0.0132	0.15
3 ft	0.0028	0.032	0.0050	0.058	0.0070	0.08	0.018	0.208	0.0264	0.30
4 ft	0.0042	0.048	0.0075	0.087	0.0105	0.12	0.027	0.312	0.0396	0.45
5 ft	0.0056	0.064	0.0100	0.116	0.0140	0.16	0.036	0.416	0.0528	0.60
6 ft	0.0070	0.080	0.0125	0.145	0.0175	0.20	0.045	0.520	0.0660	0.75
7 ft	0.0084	0.096	0.0150	0.174	0.0210	0.24	0.054	0.624	0.0792	0.90

603-13. The remaining steps of the AC voltage operation in Section 2 remain the same, with the constraints of the new specifications, i.e., 300 μV rms (-57.5 dB) to 3.1623V rms (+23 dB), into 50 Ω .

NOTE

When the internal range is changed as part of Error Mode operations, discontinuities between the ranges can occur because the available resolution greatly exceeds the permissible difference between ranges. Tests should be performed at programmed values that allow the required tolerances without automatically changing internal ranges. The points at which a one-digit LSD increment of the output results in internal ranging are 0.99999 mV, 3.1623 mV, 9.9999 mV, 31.623 mV, 99.999 mV, 0.31623V and 0.99999V.

603-14. THEORY OF OPERATION

603-15. The wideband option, as shown in Figure 603-1, is a wideband (WB) generator which uses the WB Oscillator and WB Output Amplifier PCBs of the option plus various sections of the standard calibrator. The overall block, and each component block, is described in the following paragraphs.

603-16. WB Option

603-17. Frequencies from 100 kHz to 10 MHz are generated by the WB Oscillator while frequencies from 10 Hz to 90 kHz are generated by the oscillator described in Section 3. Either of the oscillators drives the WB Output, which amplifies the voltage to the 3.1623V level required by the output, and has output current sufficient to drive the 50 ohm load.

603-18. WB OSCILLATOR

603-19. The WB Oscillator generates frequencies from 100 kHz to 10 MHz. The frequencies are produced by mixing a 20 MHz reference with frequencies produced by the Voltage Controlled Oscillator (VCO) of 20.1 to 30 MHz. The corresponding difference signal from the mixer varies from 100 kHz to 10 MHz. The mixer output is filtered by a 10 MHz low pass filter and amplified to the level required by the WB Output Amplifier. The output from the WB Oscillator is varied over a range of a little over 3 to 1 by changing the amplitude of the 20 MHz reference input to the mixer. This amplitude variation is produced by a voltage controlled amplitude modulator whose gain changes as a function of a DC voltage "Control".

603-20. The 20 MHz reference signal is generated by an L-C Oscillator, and applied to the amplitude modulator and the 200:1 divider. The VCO, $\div N$ Divider, and Phase Detector form a phase-locked loop. The VCO output is divided by the $\div N$ Divider to produce a 100 kHz signal which is compared with a 100 kHz reference produced by dividing the 20 MHz reference by 200:1. The two 100 kHz signals are applied to the phase detector which produces a DC output proportional to the difference in phase. The phase detector output causes the VCO to produce a frequency which, when divided down by the $\div N$ Divider, is 100 kHz. The $\div N$ Divider is programmed such that it will divide by 201 to produce a 20.1 MHz VCO output and by 300 for a 30 MHz output. The VCO output is then mixed with the 20 MHz reference to produce the output frequencies explained above.

603-21. WB OUTPUT AMPLIFIER

603-22. This amplifier is used to produce the output voltage and current required for a 50 ohm load. It also contains the 50 ohm Attenuator and Thermal Converter. The output of the Power Amplifier varies from 1 to 3.1623V. Lower voltages are obtained from the 50 ohm Attenuator, which is programmed in seven 10 dB steps to reduce the output down to as low as 300 μV with 1V input and 70 dB of attenuation. The Thermal Converter produces a DC output that is proportional to the rms value of the power amplifier output voltages.

603-23. Amplitude Control Loop

603-24. The output amplitude is leveled to the required output voltage by the Amplitude Control Loop. The output voltage is converted by the Thermal Converter to a DC voltage. This voltage is compared with DAC output by the integrator in the same manner as explained previously in Section 3. The integrator output "Control" is applied to the U103 current controlled resistor or to the amplitude modulator in the WB Oscillator. If the output frequency required is in the range of 10 Hz to 90 kHz, U103 will vary the input to Power Amplifier A1 and thereby vary the input to the power amp in the WB Output Amplifier. If the output frequency is in the range of 100 kHz to 10 MHz, the amplitude modulator will use "Control" to vary the WB Oscillator output as explained above. Any difference between the Thermal Converter output and the DAC output will cause the integrator to vary the signal into, and, therefore, signal out of, the WB Output Amplifier and bring the output voltage to the required value.

603-25. MAINTENANCE

603-26. The option consists of two PCBs installed in the analog compartment of the 5100 Series B Calibrators. For general maintenance procedures refer to Section 4 of this manual.

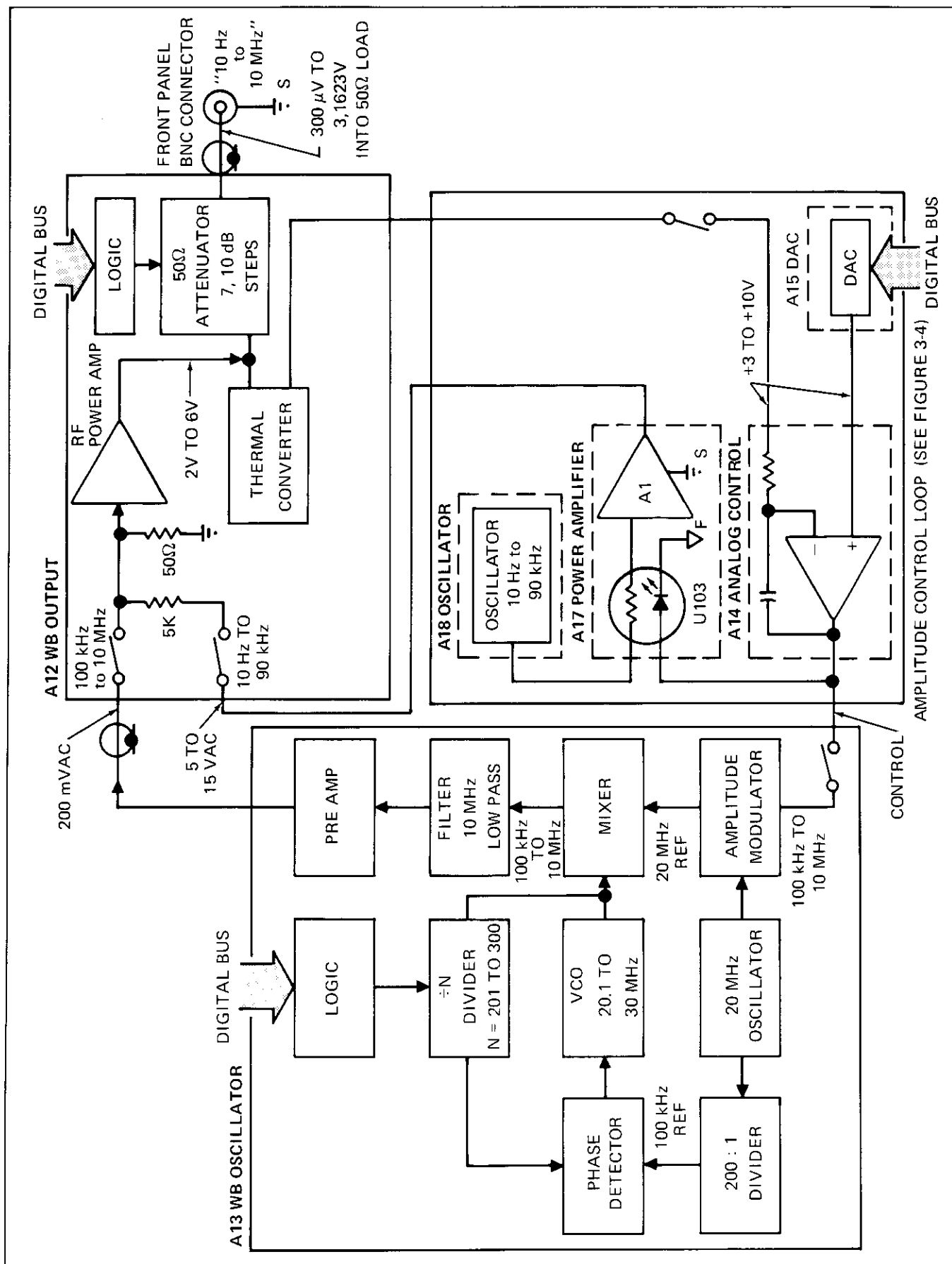

Figure 603-1. WB Option Block Diagram

603-27. PERFORMANCE TEST

603-28. The wideband performance test consists of tests for accuracy in voltage, flatness, and frequency. Test equipment required for the performance test, in addition to those listed in Section 4, are listed in Table 603-2. If the calibrator does not pass the performance test, perform the calibration or troubleshooting procedures, as is deemed applicable by the symptoms. Any repairs resulting from troubleshooting should be followed by a performance test and/or calibration procedure. Perform each of these tests using the applicable portion of the following procedures.

Table 603-2. Additional Test Equipment (Wideband)

ITEM	NOMENCLATURE
Oscilloscope	Tektronix Model 7613
Spectrum Analyzer	Tektronix Model 7L13 Plug-In
True RMS Voltmeter with dc analog output proportional to meter reading — 10 MHz minimum frequency response.	Fluke 8920A
Digital dc Voltmeter with 1 μ V sensitivity (this is a required second DMM)	Fluke 8800A
Standard Attenuators	3 ea. 20 dB GR874-G20L 1 ea. 10 dB GR874-G10L
20 dB (X10) "pad" 50 Ω Termination	Tektronix 011-0054-02 Tektronix 011-0049091
Thermal Converter and Accessories	
Thermal Converter	3V Fluke A55
Thermal Converter Cable	Fluke P/N 122325
Coaxial Tee	GR874-TL
RF 50 Ω Load	GR874-W50BL
Adapter	GR874-QBJL
Coaxial Cable	12" BNC to BNC RG58
Precision 50 Ω Load	2 each 100 Ω \pm 0.1% Metal Film in Parallel

603-29. Wideband Frequency Tests

1. Connect the wideband output connector to a frequency counter input with coaxial cable.
2. Program an output at each frequency in Table 603-3 at 1V rms and verify the counter reads within the frequency range listed for the programmed frequency.

Table 603-3. Wideband Frequency Test

CALIBRATOR FREQUENCY OUTPUT	COUNTER READING	
	MINIMUM	MAXIMUM
10 Hz	9.7 Hz	10.3 Hz
20 Hz	19.4 Hz	20.6 Hz
50 Hz	48.5 Hz	51.5 Hz
100 Hz	97 Hz	103 Hz
1 kHz	970 Hz	1030 Hz
10 kHz	9.7 kHz	51.5 kHz
50 kHz	48.5 kHz	51.5 kHz
100 kHz	97 kHz	103 kHz
500 kHz	485 kHz	515 kHz
1 MHz	0.97 MHz	1.03 MHz
3 MHz	2.91 MHz	3.09 MHz
5 MHz	4.85 MHz	5.15 MHz
10 MHz	9.7 MHz	10.3 MHz

603-30. Wideband Voltage Tests

1. Select STDBY on the calibrator.
2. Connect the equipment as shown in Figure 603-2.
3. Select the voltage settings in step 1 of Table 603-4 for each of the instruments listed.
4. Select a calibrator output frequency of 1 kHz.
5. Select OPR on the calibrator.
6. Select the calibrator Error Mode and modify the output until a null is obtained on the RMS Differential Voltmeter.
7. Verify the displayed error is no greater than the allowable error for the programmed calibrator output of the applicable step.
8. Select STDBY on the calibrator.
9. Repeat steps 3 through 8 for the remainder of Table 603-4.

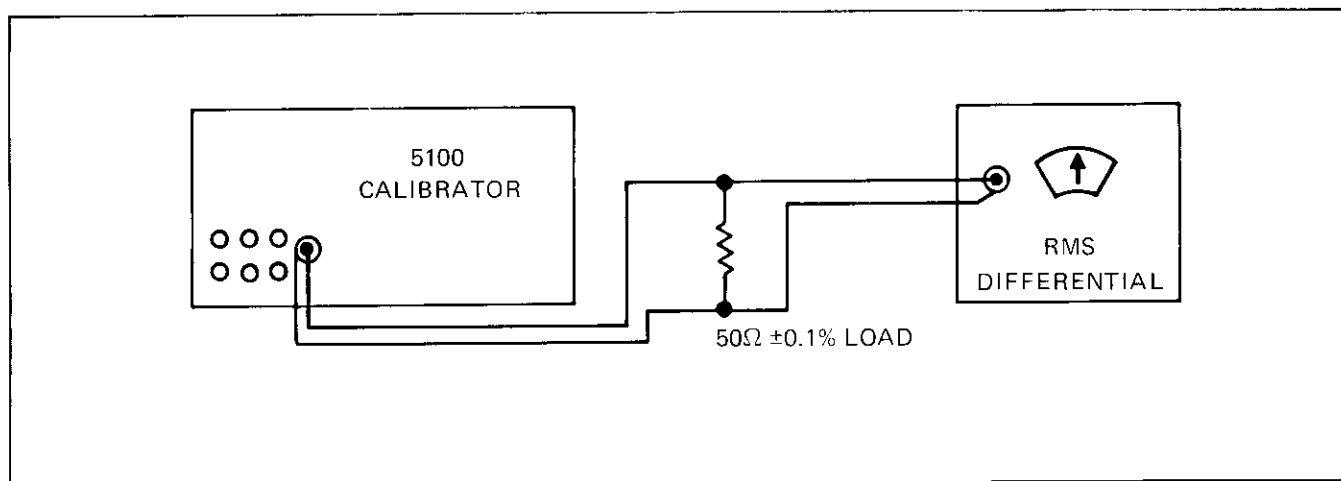

Figure 603-2. Wideband Accuracy Tests

Table 603-4. Wideband Accuracy Tests

STEP	CALIBRATOR PROGRAMMED OUTPUT VOLTAGE	RMS DIFFERENTIAL VOLTMETER SETTING	MAXIMUM CALIBRATOR % ERROR	TEST EQUIPMENT % ERROR	TOTAL PERMISSIBLE % ERROR ON CALIBRATOR DISPLAY
1	3.1585V	3.1585V	±0.5000	±0.1650	±0.6650
2	2.0000V	2.0000V	±0.6250	±0.1750	±0.8000
3	1.0000V	1.0000V	±1.0000	±0.1550	±1.1550
4	0.99999V	0.99999V	±0.7500	±0.1550	±0.9050
5	0.31623V	0.31623V	±1.0000	±0.1650	±1.1650
6	99.999 mV	99.999 mV	±1.2500	±0.1550	±1.4050
7	31.623 mV	31.623 mV	±1.5000	±0.1650	±1.6650
8	9.999 mV	9.999 mV	±1.7500	±0.2000	±1.9500

603-31. Wideband Flatness Tests

603-32. LOW FREQUENCY FLATNESS TESTS

603-33. Perform the Low Frequency Flatness test using the following procedure:

1. Connect the equipment as shown in Figure 603-3.
2. Select autoranging on the DMM.
3. Program the calibrator for 2.9V rms 1 kHz wideband output.
4. Select OPR on the calibrator.
5. Record the reading on the DMM.
6. Program the calibrator for a 2.9V rms 100 Hz wideband output.
7. Select the calibrator Error Mode and modify the calibrator output until the DMM reads the value recorded in step 5 above.
8. Verify the displayed error is no greater than $0 \pm 0.25\%$.
9. Program the calibrator for a 2.9V rms 10 Hz wideband output.
10. Repeat step 7 above.
11. Verify the displayed error is no greater than $0 \pm 0.3\%$.
12. Select STDBY on the calibrator.

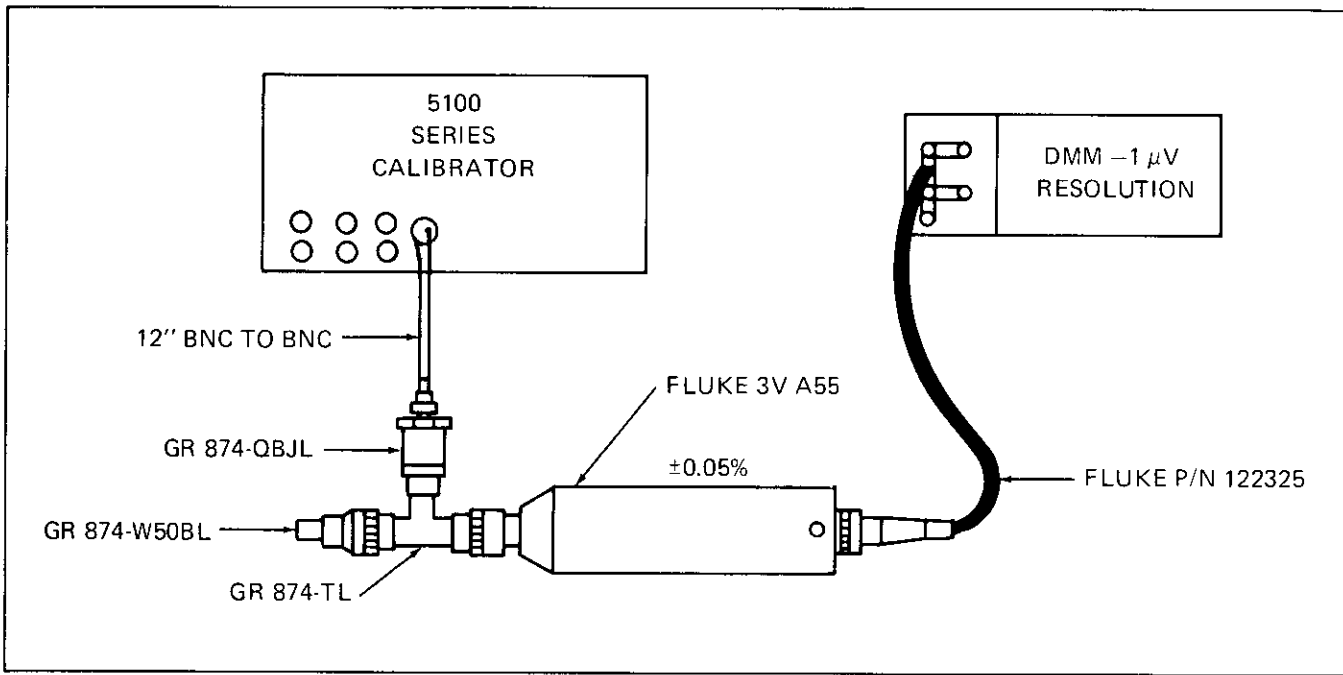

Figure 603-3. Wideband Low Frequency Flatness Tests

603-34. MEDIUM AND HIGH FREQUENCY FLATNESS TESTS

603-35. Verification of the wideband flatness requires termination of the output with the specified 50 ohms. This can be accomplished by using either a 50 ohm input impedance thermal converter or, as in the case of the following procedure, a 50 ohms input impedance detector characterized for flatness using a non-50 ohm converter, i.e., the Fluke A55.

NOTE

The procedure does not cover attenuator flatness since this is not deemed necessary for routine verification. If such a test is desired refer to the attenuator flatness verification portion of the Calibration Procedure.

603-36. 50Ω Detector Characterization

603-37. Characterize the 50Ω detector using the following procedure:

1. Connect the equipment as shown in Figure 603-4.
2. Program a wideband calibrator output of 2.9V at 1 kHz.
3. Select the Error Mode and with the EDIT switch obtain a convenient reference reading (e.g., 0.2900V) on the DMM connected to the rf voltmeter analog output.

4. Allow approximately five minutes for stabilization, then record the display on the DMM connected to the rf voltmeter analog output and the DMM connected to the thermal converter (sample recording form in Figure 603-5).

5. Program in turn outputs of 100 kHz, 10 MHz, 3 MHz, 5 MHz, and 10 MHz. At each frequency use the Error Mode EDIT switch to obtain the Thermal Converter DMM indication recorded in step 4 above, then record the reading displayed on the rf voltmeter DMM.

NOTE

When the internal range is changed as part of Error mode operations, discontinuities between the ranges can occur because the available resolution greatly exceeds the permissible difference between ranges. The test should be performed at programmed values that allow the required tolerances without automatically changing internal ranges. The points at which a one digit LSD increment of the output results in internal ranging are 0.99999 mV, 3.1623 mV, 9.9999 mV, 31.623 mV, 99.999 mV, 0.31623V, and 0.99999V.

6. When all frequencies are tested, return to the 1 kHz setting and verify the reading on the Thermal Converter DMM and rf voltmeter DMM is the same as originally recorded. Repeat the test if required.

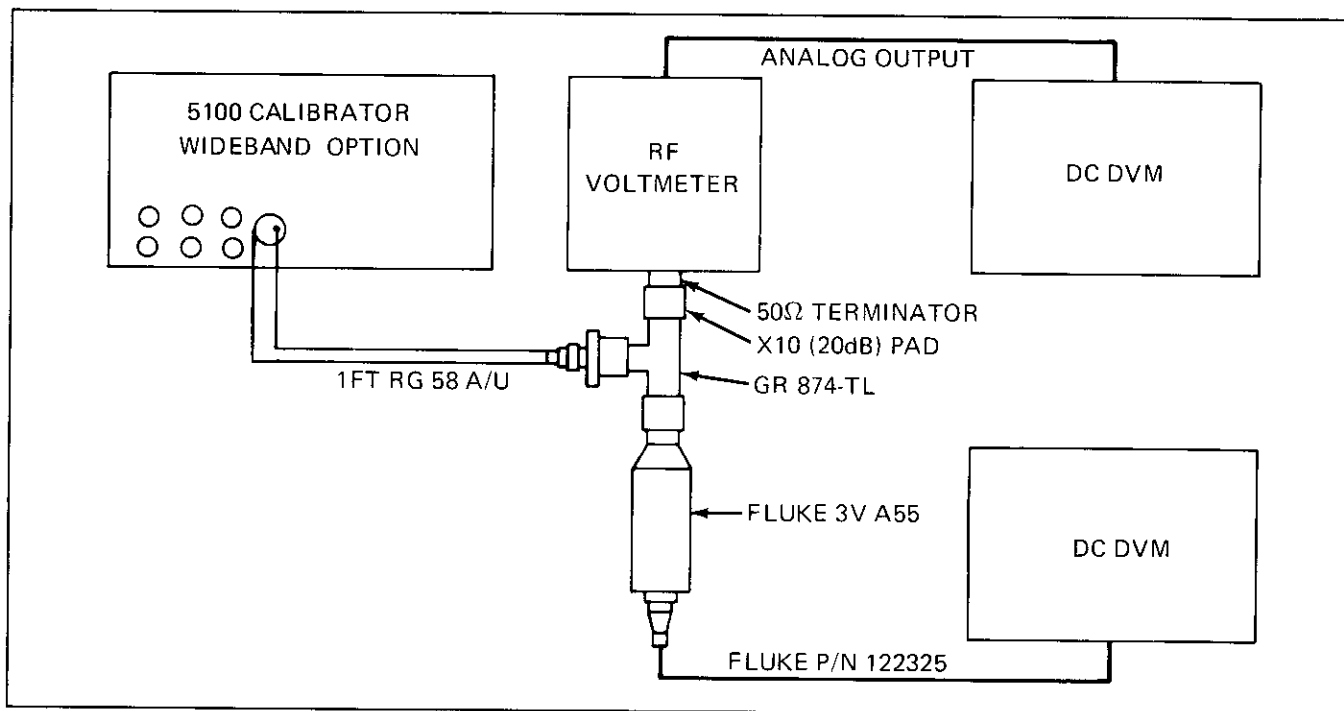

Figure 603-4. Wideband Flatness Tests Characterization

STEP	FREQUENCY	50Ω DETECTOR CHARACTERIZATION		FLATNESS TEST % OF ERROR DISPLAYED
		RF VOLTMETER/ DMM READING	THERMAL CONVERTER/ DMM READING	
1	1 kHz (Ref)	_____	_____	0.0000%
2	100 kHz	_____	_____	_____
3	1 MHz	_____	_____	_____
4	3 MHz	_____	_____	_____
5	5 MHz	_____	_____	_____
6	7 MHz	_____	_____	_____
7	10 MHz	_____	_____	_____
8	1 kHz	_____	_____	_____
		(Must be same as step 1)	(Must be same as step 1)	(0 ±0.02%)

Figure 603-5. Sample Form for 50Ω Flatness Tests

603-38. Medium and High Frequency Verification

603-39. Verify the flatness of the wideband at medium and high frequencies using the following procedure:

1. Connect the equipment as shown in Figure 603-6.
2. Program a wideband calibrator output of 2.9V at 1 kHz.
3. Select the Error Mode on the calibrator and with the EDIT switch obtain the reading on the rf voltmeter. DMM recorded during the characterization procedure at 1 kHz.

4. Depress the NEW REF/CAL 1Ω switch on the calibrator and verify the Central Display reads .0000% error.

NOTE

To avoid changing the error reference level during the remainder of the test, all changes in voltage and frequency must be made with the Error Mode controls. Select the function to be changed, voltage or frequency, with the decade switches (◀ DECADE or DECADE ▶) and then alter the selected figure with the EDIT switch.

5. With the Error Mode EDIT switch obtain a 100 kHz output, then, with the EDIT switch, adjust the output voltage for a display on the DMM of the figure recorded at that frequency during characterization.
6. The Central Display should read no greater than $0 \pm 0.25\%$ ERROR at the recorded figure.
7. Repeat steps 5 and 6 for 1 MHz, 3 MHz, and 5 MHz.
8. Repeat steps 5 and 6 for 7 MHz and 10 MHz allowing an error of $0 \pm 0.6\%$.
9. Return to the 2.9V at 1 kHz initial setting using the EDIT switch and verify the Central Display read $0 \pm 0.02\%$. Repeat the test if this step is not within the stated tolerance.

603-40. CALIBRATION PROCEDURE

603-41. General Preparation

NOTE

Data acquired during the performance test is required to perform the calibration procedure. Complete the performance test immediately prior to starting the calibration procedure to insure the validity of the reference data.

603-42. If the instrument does not meet, or cannot be adjusted to meet, the listed tolerance in any step the instrument does not meet the calibration requirements and should be repaired.

603-43. During calibration of the 5100 B Series Calibrators all outputs should be manually programmed on the front panel.

603-44. Test equipment required, in addition to those listed in Table 4-1, is listed in Table 603-2.

603-45. Oscillator Calibration Procedure

603-46. EQUIPMENT PREPARATION

603-47. Perform the following steps prior to beginning calibration of the Wideband Oscillator:

1. Remove the Analog Control PCB (A14) from the calibrator.
2. Remove the Wideband Oscillator PCB (A13) from the calibrator. Remove the front shield and reinstall the PCB in the calibrator on an extender PCB.

NOTE

Refer to the reference designator WB Oscillator drawing to establish component locations during the calibration procedure.

3. Apply power to the instrument and select WIDEBAND.

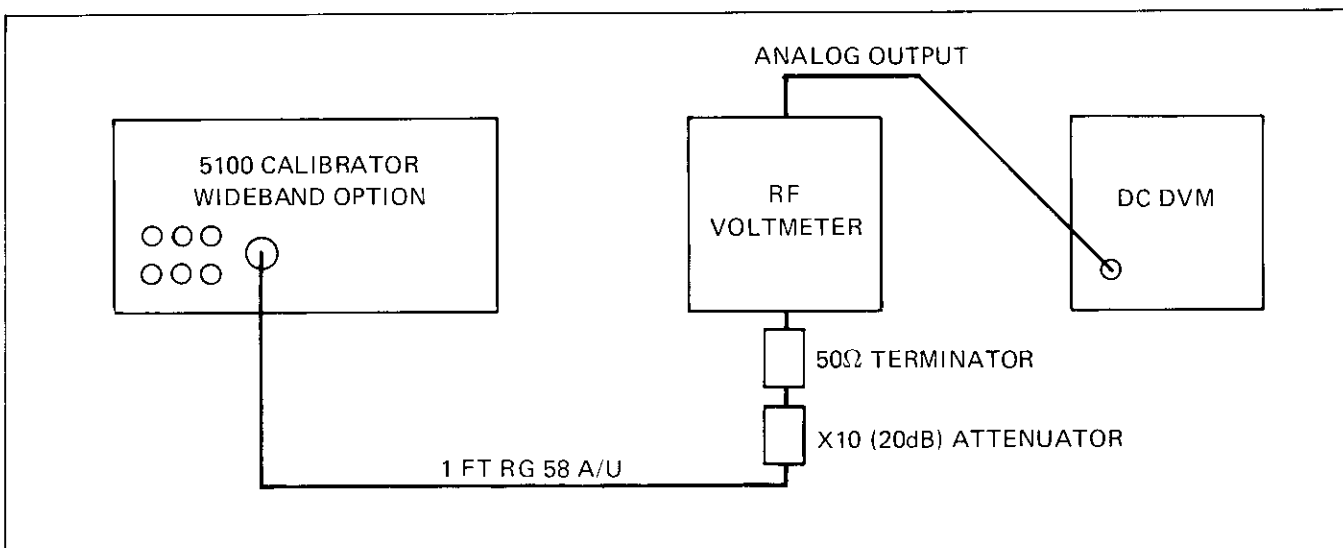

Figure 603-6. Wideband Medium and High Frequency Flatness Tests

603-48. OSCILLATOR ADJUSTMENTS

603-49. Adjust the Wideband 2 MHz Oscillator using the following procedure:

1. Connect a frequency counter between TP7 (HI) and TP9 (LO) on the Oscillator Assembly.
2. Program a calibrator wideband output of 1 volt at 100 kHz.
3. Adjust T1 for reading on the counter between 19.9800 and 20.0200 MHz.
4. Connect TP17 and TP15 (+5V) on the Oscillator Assembly with a jumper.
5. Connect the scope to TP13 and TP9 (ground).
6. Adjust L11 for a maximum signal.
7. Connect a short between TP9 and TP10.
8. Connect the spectrum analyzer to TP8.
9. Adjust L14 for a minimum 20 MHz signal.
10. Remove the short between TP9 and TP10.
11. Adjust L15 for a maximum 20 MHz signal.
12. Repeat steps 6 through 10 until the minimum and maximum are present without interaction.
13. Disconnect the frequency counter from the instrument.

NOTE

Offset errors can result in subsequent test if the frequency counter is not removed.

14. Connect the scope to TP2 and TP9 (ground).
15. Manually program the calibrator for an output of 1V ac at 100 kHz.
16. Adjust T2 for a 2.5V dc display on the scope.
17. Manually program the calibrator for an output of 1V ac at 10 MHz.
18. The DC voltage displayed on the scope should be between 9 and 11V dc.

603-50. DC OFFSET CALIBRATION

603-51. Perform the DC Offset Calibration using the following procedure:

1. Disconnect the jumper between TP15 and TP17.
2. Connect the scope to J123 output connector.
3. Adjust R59 for a scope display of less than 100 mV dc.

603-52. OUTPUT LEVEL CALIBRATION

603-53. Perform the Output Level Calibration using the following procedure:

1. Replace the Analog Control PCB (A14).
2. With the wideband output cable connect J123 to the Wideband Output (A12).
3. Connect a BNC "T" connector to the wideband output on the front panel. Connect the rms differential voltmeter to one side of the T and the 50 ohm precision termination to the other.
4. Manually program the calibrator for a wideband output of 3.1623V ac at 100 kHz.
5. Adjust R36 for a 3.1623 volt reading on the rms differential voltmeter.

603-54. HIGH FREQUENCY BALANCE AND ROLL-OFF CALIBRATION

603-55. Perform the HF Balance and Roll-Off Calibration using the following procedure:

1. Connect the spectrum analyzer to the wideband front panel output through a 20 dB attenuator.
2. Manually program the calibrator for a wideband output of 3.1623V ac at 9 MHz.
3. Tune the analyzer to observe the spurious signal at 11 MHz.
4. Adjust R53 for the minimum signal on the analyzer. It must be at least 56 dB down from the 9 MHz signal.
5. Manually program the calibrator for a wideband output of 3.1623V ac at 400 kHz.

6. Tune the analyzer to center the 20.4 MHz signal.
7. Adjust L23 counterclockwise until the 20.4 MHz signal increases; then turn L23 clockwise until the 20.4 MHz signal is minimum.

603-56. FREQUENCY RESPONSE CALIBRATION

603-57. Perform the Frequency Response Calibration using the following procedure:

1. Connect the test DMM between TP17 (H1) and TP9 (LO).
2. Manually program a calibrator wideband output of 3.1623V ac at 10 MHz.
3. Adjust R36 for a reading of 5.2V dc.
4. Vary the programmed frequency between 9 MHz and 1 MHz in 1 MHz steps; and from 900 kHz to 100 kHz in 100 kHz steps.
5. Verify the displayed voltage stays between 4.5 and 5.5V dc at all frequency steps.

603-58. Output Calibration Procedure

603-59. EQUIPMENT PREPARATION

603-60. Perform the following steps prior to beginning calibration of the wideband output:

1. Remove the Wideband Output PCB (A12) from the calibrator. Remove the front shield and reinstall the PCB in the calibrator on an extender PCB.

CAUTION

Insure the heat sink plate is properly installed and in place on the PCB before reapplying power. It is possible to remove the plate with the shield if all screws are not removed in conjunction with the shield removal.

2. Verify the cable connecting the WB Oscillator (A13) to the WB Output (A12) and the output to the front panel connector are in place and connected.

NOTE

Refer to the reference designator WB output drawing to establish component locations during the calibration procedure.

3. Verify that C6 is turned the maximum clockwise, with the screw adjustment all the way in.

603-61. BIAS AND DC OFFSET ADJUSTMENTS

603-62. Adjust the bias and DC offset voltage using the following procedure:

1. Connect the test DMM between TP1 (H1) and TP2 (LO) on the Output Assembly.
2. Adjust R36 for a reading between 0.73 and 0.77V dc.
3. Connect the test DMM between TP2 (H1) and ground.
4. Adjust R14 for a reading of 0 ± 10 mV dc.

603-63. RMS SENSOR ALIGNMENT

603-64. Align the rms sensor circuit using the following procedure:

1. Connect the rms differential voltmeter to the wideband Output terminal with the 50 ohm precision terminator.
2. Manually program a calibrator output of 3V ac at 1 kHz.
3. Set the rms differential voltmeter for 3.0000V ac.
4. Adjust R79 for a null on the voltmeter.
5. Manually program a calibrator output of 1V ac at 1 kHz.
6. Set the RMS differential voltmeter for 1.0000V ac.
7. Adjust R74 for a null on the voltmeter.
8. Repeat steps 2 through 7 until both outputs null without an adjustment.
9. Manually program a calibrator output of 2V ac at 1 kHz.
10. Set the RMS differential voltmeter for 2.0000V ac.
11. Verify the voltmeter reads a null $\pm 0.2\%$.
12. Manually program a calibrator output of .99999V ac at 1 kHz.

13. Set the rms differential voltmeter for 1.0000V ac.
14. Adjust R85 for a null on the voltmeter.

603-65. HIGH FREQUENCY OUTPUT CALIBRATION

603-66. Adjust the high frequency output using the following procedure:

1. Connect the test equipment as shown in Figure 603-6.
2. Program a calibrator output of 2.9999V ac at 1 kHz. Using the EDIT switch vary the calibrator output until the rf voltmeter; DMM reads the figure recorded for 1 kHz in Figure 603-5.
3. Program a calibrator frequency of 5 MHz.
4. Adjust C40 to obtain on the rf voltmeter; DMM the value recorded for 5 MHz in the rf voltmeter column of Figure 603-5.

603-67. Attenuator Flatness Verification

603-68. This procedure is not deemed necessary for routine recalibration, provided the flatness portion of the performance test was within the specified tolerances. However, it should be performed any time that repairs are made to the attenuator circuits, or output performance is questionable at low levels.

NOTE

Check the DC resistance of the standard attenuators when terminated with 50Ω for a tolerance of ±1% on both inputs.

603-69. Perform the attenuator flatness verification using the following procedure:

1. If not just completed, perform the wideband flatness portion of the performance test, insuring the data listed in the Flatness Test % of Error Displayed column in Figure 603-5, is recorded in Row 1 of Figure 603-7 for the 1 kHz, 100 kHz, 5 MHz, and 10 MHz columns.
2. Connect the equipment as shown in Figure 603-8.
3. Program the calibrator for a wideband output of 2.9V at 1 kHz.

4. Select the Error Mode and with the EDIT switch, adjust the calibrator output for a convenient reference level (e.g., 0.29000V) on the DMM connected to the rf voltmeter.

5. Record the reading on the DMM connected to the rf voltmeter. (See the sample form in Figure 603-7.)

6. Depress the NEW REF; CAL 1Ω switch.
7. The Central Display reads .0000.

NOTE

During the remainder of the test all changes in voltage or frequency must be made with the Error Mode controls. Select the function to be changed, voltage or frequency, with the decade switches (◀ DECADE or DECADE ▶) and then alter the selected figure with the EDIT switch.

8. With the Error Mode EDIT switch set the DMM to the reading recorded in step 5 at frequencies of 100 kHz, 5 MHz, 10 MHz, and 1 kHz, and record the % of error displayed at each frequency (see sample form in Figure 603-7, Row 2, Column 2, 3, 4, and 5, respectively). If the second error reading at 1 kHz is greater than 0.0000% repeat the test.

NOTE

The wideband flatness portion of the performance test is sufficient for low frequencies and no further tests are made during the attenuator flatness verification.

9. Repeat steps 3 through 8 for the remaining test (Rows 6, 9, 12, 15, 18) shown in Figure 603-7. Remove and insert the 10 dB and 20 dB standard attenuators as required to obtain the attenuation listed for that row in each column. Enter the Central Display reading in the applicable space on the form for each test.

NOTE

Complete all measurements before performing the computation to insure the reference (Row 2) remains valid.

10. Perform the computations listed subsequent to each test and compare the result in the double underlined rows (5, 8, 11, 14, 17, 20) to the applicable tolerance in Row 21 (0.25% for columns 2 and 3, and 0.6% for Column 4).

ROW	ACTION	COLUMN	COLUMN 1	COLUMN 2	COLUMN 3	COLUMN 4	COLUMN 5
		FREQ	1 kHz	100 kHz	5 MHz	10 MHz	1 kHz
Row 1	Flatness % of Error from Fig. 603-5		0.0000				
Row 2	Reference Point 60 dB \approx 2.9V		0.0000				
Row 3	50 dB \approx 0.9V						
Row 4	(Row 3) – (Row 2)						
Row 5	(Row 4) – (Row 1)						
Row 6	40 dB \approx 290 mV						
Row 7	(Row 6) – (Row 2)						
Row 8	(Row 7) – (Row 1)						
Row 9	30 dB \approx 90 mV						
Row 10	(Row 9) – (Row 2)						
Row 11	(Row 10) – (Row 2)						
Row 12	20 dB \approx 29 mV						
Row 13	(Row 12) – (Row 2)						
Row 14	(Row 13) – (Row 1)						
Row 15	10 dB \approx 9 mV						
Row 16	(Row 15) – (Row 2)						
Row 17	(Row 16) – (Row 1)						
Row 18	0 dB \approx 2.9 mV						
Row 19	(Row 18) – (Row 2)						
Row 20	(Row 19) – (Row 1)						
Row 21	Tolerance			0.2500%	0.2500%	0.6000%	

Figure 603-7. Attenuator Flatness Verification Sample Form

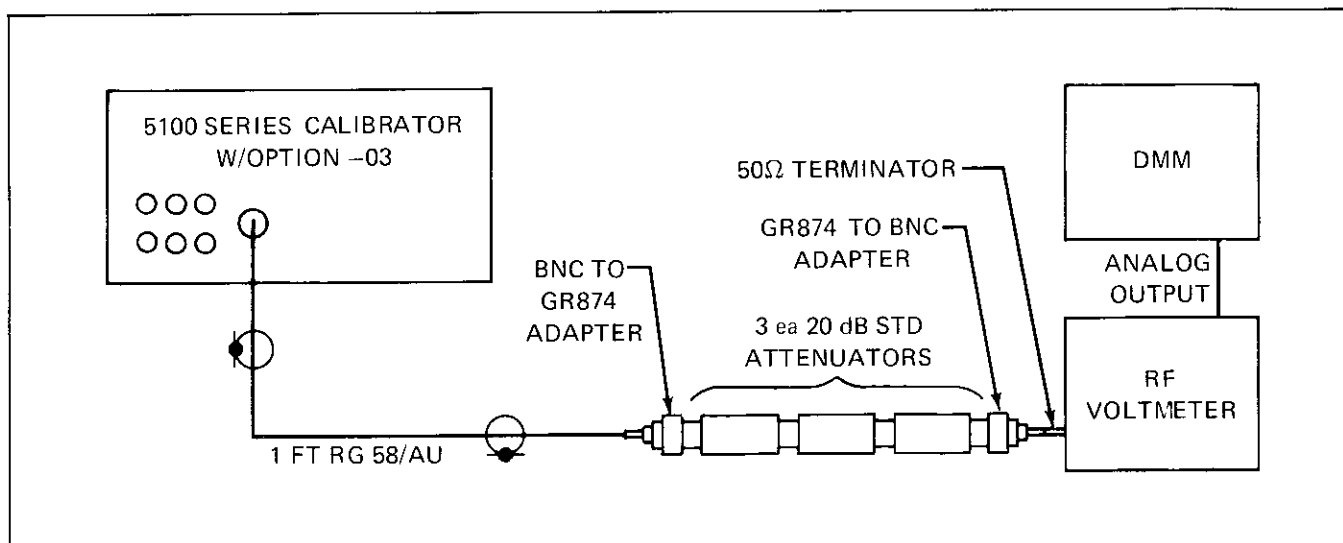

Figure 603-8. Attenuator Flatness Verification Connections

603-70. TROUBLESHOOTING

603-71. Troubleshooting for the -03 Wideband Frequency Option consists of the tabular flow chart in Table 603-5. When a step in the flow chart is completed, check for a decision transfer. If no decision is required, perform the next step of the table in sequence.

603-72. LIST OF REPLACEABLE PARTS

603-73. The wideband option consists of two assemblies and a connecting coaxial cable (J113, J123, Fluke and Mfg. Stock No. 205880 and Mfg. Supply Code 89536). Tables 603-6 and 603-7 contain lists of replaceable parts for the two assemblies. Refer to Section 5 for an explanation of the columnar entries.

Table 603-5. Wideband Option Troubleshooting

STEP NO.	ACTION	Go to the step number given for correct response	
		YES	NO
1	Select WIDEBAND and ENTER, then program an output of 3.1623V at 100 kHz.		
2	Check the voltage at the Wideband Output terminal with RMS differential voltmeter as shown in Figure 603-2.		
3	Does the differential voltmeter read 3.1623V ac $\pm 0.5\%$?	16	4
4	Check the input voltages at the following points: On the Oscillator Assembly with low at TP9 check at TP12 for $+15 \pm 0.05V$ dc, at TP11 for $-15 \pm 0.2V$ dc and at TP1 for $-20 \pm 0.25V$ dc. On the Output Assembly with low at the connector shield of J113 check TP4 for $+15 \pm 0.5V$ dc, at TP5 for $-15 \pm 0.2V$ dc and at TP6 for $-20 \pm 0.25V$ dc.		
5	Are all voltages present and within the stated tolerance?	7	6
6	Check the circuits and the input from the power supply regulator. Repair as required then resume at step 2.		
7	Is 9 volts peak-to-peak present at J114 on the Output Assembly with the output terminals terminated with 50 ohms?	9	8
8	Check the cable and connections between the Output Assembly output at J114 and the front panel output terminal. Repair as required then resume at step 2.		
9	Is 18V peak-to-peak present at TP2 on the Output Assembly?	11	10
10	Check the output attenuator circuit on the Output Assembly. Check Table 603-7, for the correct divider states with the frequency selected. Check Table 603-8, for the relay states for the output voltage selected. Check at U4-9 (A12), U7-6 (A13), and U7-8 (A13) for a clock pulse train with approximately 20 ms period. Repair as required then resume at step 2.		
11	Is 0.9 volts peak-to-peak present at TP3 on the Output Assembly?	13	12
12	Check the amplifier circuit on the Output Assembly. Repair as required then resume at step 2.		
13	Is 0.9 volts peak-to-peak present at J123 on the Oscillator Assembly?	14	15
14	Check K1, K2, and their associated circuitry on the Output Assembly plus the cabling and connectors between the Output and Oscillator Assemblies. Repair as required then resume at step 2.		
15	<p>The problem lies within the Oscillator Assembly. Isolate the fault to a stage by checking the signals at the points below with an Oscilloscope using a 10:1 probe. All signals voltages given are for peak-to-peak (p-p) waveforms in relation to TP9 with a programmed output 3.1623V at 100 kHz. The frequency given is the frequency of the waveform, not the programmed output.</p> <ul style="list-style-type: none"> Collector Q20 – 3V p-p at 100 kHz and Harmonics Base Q18 – 500 mV p-p at 100 kHz and Harmonics Collector Q17 – 1V p-p at 100 kHz and Harmonics Base Q15 – 190 mV p-p at 100 kHz and Harmonics U20-4 – 100 mV p-p at 20 MHz and Harmonics U20-8 – 1.2V p-p at 20.1 MHz and Harmonics TP10 – 0.9V p-p at 20 MHz TP8 – 100 mV p-p at 20 MHz and Harmonics TP13 – 1V p-p at 20 MHz and Harmonics TP3 – 4V p-p at 20.1 MHz and Harmonics TP7 – 4V p-p at 20 MHz <p>Repair as required then resume at step 2.</p>		

Table 603-5. Wideband Option Troubleshooting (cont)

STEP NO.	ACTION	Go to the step number given for correct response	
		YES	NO
16	Check the frequencies of the output signal with a Frequency Counter. The programmed output should be 3.1623V at 100 kHz.		
17	Is the frequency 100 kHz $\pm 3\%$?	34	18
	<i>NOTE</i> All of the following levels on the Oscillator Assembly are in relation to TP9.		
18	Is a 20 MHz signal present at TP7 of the Oscillator Assembly?	20	19
19	Check the 20 MHz Oscillator circuit on the Oscillator Assembly. Repair as required then resume at step 16.		
20	Is a 20-30 MHz signal present at TP3 of the Oscillator Assembly?	22	21
21	Check the VCO circuit on the Oscillator Assembly. Repair as required then resume at step 16.		
22	Is the following waveform present at TP4?	24	23
23	Check the 201-300:1 Divider Circuit on the Oscillator Assembly. Repair as required then resume at step 16.		
24	Is the following waveform present at TP5?	26	25
25	Check the 200:1 Divider Circuit on the Oscillator Assembly. Repair as required then resume at step 16.		

Table 603-6. Wideband Output PCB Assembly

REF DES	DESCRIPTION	FLUKE STOCK NO.	MFG SPLY CODE	MFG PART NO. OR TYPE	TOT QTY	REC QTY	N O T E
A12	⊗ WIDEBAND OUTPUT PCB ASSEMBLY FIGURE 603-9	ORDER	BY	OPTION -03 (PART)			
C1	CAP,CER,0.22 UF+/-20%, 50V	309849	71590	CW30C224K	6		
C2	CAP, TA, 68 UF+/-20%, 15V	193615	56289	196D68X0015TE4	2		
C3	CAP, TA, 68 UF+/-20%, 15V	193615	56289	196D68X0015TE4		REF	
C4	CAP, TA, 4.7 UF+/-20%, 25V	161943	56289	196D475X0025KA1	1		
C5	CAP,CER,0.22 UF+/-20%, 50V	309849	71590	CW30C224K		REF	
C6	CAP, VAR, 0.25-1.5PF, 200V	218206	72982	530-000	1		
C7	CAP, CER, 0.01 UF +/-20%, 100V	149153	56289	C023810F103M	5		
C8	CAP, CER, 0.0012 UF +/-20%	106732	71590	CF122	3		
C9	CAP,MICA, 430 PF +/-5%, 500V	177980	72136	DM15F431J	1		
C10	CAP, CER, 0.01 UF +/-20%, 100V	149153	56289	C023810F103M		REF	
C11	CAP, CER, 0.01 UF +/-20%, 100V	149153	56289	C023810F103M		REF	
C12	CAP, TA, 6.8UF+/-20%, 35V	363713	56289	196D685X0035KA1	2		
C13	CAP, CER, 0.05 UF+/-20%, 100V	149161	56289	55C23A1	4		
C14	CAP, CER, 0.05 UF+/-20%, 100V	149161	56289	55C23A1		REF	
C15	CAP, TA, 6.8UF+/-20%, 35V	363713	56289	196D685X0035KA1		REF	
C16	CAP, CER, 0.22 UF+/-20%, 50V	309849	71590	CW30C224K		REF	
C17	CAP, CER, 0.22 UF+/-20%, 50V	309849	71590	CW30C224K		REF	
C18	CAP, CER, 0.22 UF+/-20%, 50V	309849	71590	CW30C224K		REF	
C19	CAP, CER, 0.05 UF+/-20%, 100V	149161	56289	55C23A1		REF	
C20	CAP, CER, 0.05 UF+/-20%, 100V	149161	56289	55C23A1		REF	
C21	CAP, TA, 22UF+/-20%, 25V	357780	56289	1960226X0025PE4	4		
C22	CAP, TA, 22UF+/-20%, 25V	357780	56289	1960226X0025PE4		REF	
C23	CAP, TA, 22UF+/-20%, 25V	357780	56289	1960226X0025PE4		REF	
C24	CAP, TA, 22UF+/-20%, 25V	357780	56289	1960226X0025PE4		REF	
C25	CAP, TA, 10UF+/-20%, 20V	330662	56289	196D106X0020KA1	5		
C26	CAP, TA, 10UF+/-20%, 20V	330662	56289	196D106X0020KA1		REF	
C27	CAP, TA, 10UF+/-20%, 20V	330662	56289	196D106X0020KA1		REF	
C28	CAP, MICA, 56PF+/-5%, 500V	148528	72136	DM15F560J	1		
C30	CAP, CER, 0.01UF+/-20%, 100V	149153	56289	C023B101F103M		REF	
C31	CAP, CER, 0.01UF+/-20%, 100V	149153	56289	C023B101F103M		REF	
C32	CAP, CER, 0.0012UF+/-20%	106732	71590	CF122		REF	
C33	CAP, MTL POLYCARB, 0.33UF+/-10%, 50V	284703	84411	X463UW3349.50W	2		
C34	CAP, MICA, 33PF+/-5%, 500V	160317	72136	DM15E330J	1		
C35	CAP, CER, 0.0012UF+/-20%	106732	71590	CF122		REF	
C36	CAP, MTL POLYCARB, 0.33UF+/-10%, 50V	284703	84411	X463UW3349.50W		REF	
C37	CAP, TA, 10UF+/-20%, 20V	330662	56289	196D106X0020KA1		REF	
C38	CAP, TA, 10UF+/-20%, 20V	330662	56289	196D106X0020KA1		REF	
C39	CAP, CER, 0.22 UF+/-20%, 50V	309849	71590	CW30C224K		REF	
C40	CAP, VAR, CER, 1.7-10PF, 250V	321109	52769	GKB10000	1		1
CR1	DIODE, SI, HI-SPEED, SWITCHING	203323	07910	IN4448	20		4
CR2	DIODE, SI, HI-SPEED, SWITCHING	203323	07910	IN4448		REF	
CR3	DIODE, SI, HI-SPEED, SWITCHING	203323	07910	IN4448		REF	
CR4	DIODE, SI, HI-SPEED, SWITCHING	203323	07910	IN4448		REF	
CR5	DIODE, SI, HI-SPEED, SWITCHING	203323	07910	IN4448		REF	
CR6	DIODE, SI, HI-SPEED, SWITCHING	203323	07910	IN4448		REF	
CR7	DIODE, SI, HI-SPEED, SWITCHING	203323	07910	IN4448		REF	
CR8	DIODE, SI, HI-SPEED, SWITCHING	203323	07910	IN4448		REF	

Table 603-6. Wideband Output PCB Assembly (cont)

REF DES	DESCRIPTION	FLUKE STOCK NO.	MFG SPLY CODE	MFG PART NO. OR TYPE	TOT QTY	REC QTY	NO TE
CR9	DIODE, SI, HI-SPEED, SWITCHING	203323	07910	IN4448		REF	
CR10	DIODE, SI, HI-SPEED, SWITCHING	203323	07910	IN4448		REF	
CR11	DIODE, SI, HI-SPEED, SWITCHING	203323	07910	IN4448		REF	
CR12	DIODE, SI, HI-SPEED, SWITCHING	203323	07910	IN4448		REF	
CR13	DIODE, SI, HI-SPEED, SWITCHING	203323	07910	IN4448		REF	
CR14	DIODE, SI, HI-SPEED, SWITCHING	203323	07910	IN4448		REF	
CR15	DIODE, SI, HI-SPEED, SWITCHING	203323	07910	IN4448		REF	
CR16	DIODE, SI, HI-SPEED, SWITCHING	203323	07910	IN4448		REF	
CR17	DIODE, SI, HI-SPEED, SWITCHING	203323	07910	IN4448		REF	
CR18	DIODE, SI, HI-SPEED, SWITCHING	203323	07910	IN4448		REF	
CR19	DIODE, SI, HI-SPEED, SWITCHING	203323	07910	IN4448		REF	
CR20	DIODE, SI, HI-SPEED, SWITCHING	203323	07910	IN4448		REF	
H1	SCREW, PH, SEMS, 4-40X3/8 (NOT SHOWN)	152124	73734	19024	6		
H2	SCREW, FPH, 4-40X3/8 (NOT SHOWN)	152124	89536	152124	4		
J113	CONN, MALE, COAX	207639	13511	27-875	2		
J114	CONN, MALE, COAX	207639	13511	27-875		REF	
K1	RELAY, DRY REED, SPST	404590	71707	CR4503	3		
K2	RELAY, DRY REED, SPST	404590	71707	CR4503		REF	
K3	RELAY, DPDT	407536	03508	3SAV5-53-4H1	4		
K4	RELAY, DPDT	407536	03508	3SAV5-53-4H1		REF	
K5	RELAY, DPDT	407536	03508	3SAV5-53-4H1		REF	
K6	RELAY DRY REED, 1100+/-10%, 15V	341024	71482	MRB-2A15	1		
K7	RELAY, DRY REED, SPST	404590	71707	CR4503		REF	
K8	RELAY, DPDT	407536	03508	3SAV5-53-4H1		REF	
L1	FERRITE TUBE, CHOKE CORE	321182	02114	56-590-65-4B	5		
L2	FERRITE TUBE, CHOKE CORE	321182	02114	56-590-65-4B		REF	
L3	CHOKE, 6-TURN	320911	89536	320911	9		
L4	CHOKE, 6-TURN	320911	89536	320911		REF	
L5	CHOKE, 6-TURN	320911	89536	320911		REF	
L6	FERRITE TUBE, CHOKE CORE	321182	02114	56-590-65-4B		REF	
L7	CHOKE, 6-TURN	320911	89536	320911		REF	
L8	CHOKE, 6-TURN	320911	89536	320911		REF	
L9	CHOKE, 6-TURN	320911	89536	320911		REF	
L10	CHOKE, 6-TURN	320911	89536	320911		REF	
L11	CHOKE, 6-TURN	320911	89536	320911		REF	
L12	CHOKE, 6-TURN	320911	89536	320911		REF	
L13	FERRITE TUBE, CHOKE CORE	321182	02114	56-590-65-4B		REF	
L14	FERRITE TUBE, CHOKE CORE	321182	02114	56-590-65-4B		REF	
MP1	PLATE, HEATSINK MTG (NOT SHOWN)	438150	89536	438150	1		
MP2	PLATE, XSTR MTG (NOT SHOWN)	438143	89536	438143	1		
MP3	PLATE, XSTR CLAMP (NOT SHOWN)	438135	89436	438135	1		
MP4	PLATE, CONN, MTG (NOT SHOWN)	438127	89536	438127	1		
MP5	BRACKET, CONN MTG (NOT SHOWN)	462069	89536	462069	1		
MP7	SPACER, DOGBONE (NOT SHOWN)	285346	71590	J64280	8		
Q1	XSTR, SI, NPN	333898	04713	MPSH10	2		1
Q2	XSTR, SI, NPN	333898	04713	MPSH10		REF	
Q3	XSTR, SI, PNP	343012	12040	PN4258	1		1
Q4	XSTR, SI, PNP	402578	04713	2N5160	1		1
Q5	XSTR, SI, NPN	179374	12040	2N2218	2		1
Q6	XSTR, SI, NPN	402602	04713	MRF531	1		1

Table 603-6. Wideband Output PCB Assembly (cont)

REF DES	DESCRIPTION	FLUKE STOCK NO.	MFG SPLY CODE	MFG PART NO. OR TYPE	TOT QTY	REC QTY	NO TE
Q7	XSTR, SI, PNP	402586	04713	2N2905A	1	1	
Q8	XSTR, SI, NPN	407965	04713	2N3553	1	1	
Q9	XSTR, SI, PNP	229898	04713	MPS6522	2	1	
Q10	XSTR, SI, PNP	402560	04713	MM4019	1	1	
Q11	XSTR, SI, NPN	179374	12040	2N2218	REF		
Q12	XSTR, SI, NPN	218081	04713	MPS6520	1	1	
Q13	XSTR, SI, PNP	226290	04713	MPS3640	1	1	
Q14	XSTR, SI, NPN	218396	04713	2N3904	1	1	
Q15	XSTR, SI, PNP	229898	04713	MPS6522	REF		
Q16	XSTR, SI, PNP	195974	04713	2N3906	1	1	
R1	RES, MTL FILM, 2.49+/-1%, 1/8W	226209	91637	CMF552491F	1		
R2	RES, MTL FILM 52.3+/-1%, 1/8W	305912	91637	CMF5552R3F	1		
R3	RES, DEP, CAR, 1K+/-5%, 1/4W	343426	80031	CR251-4-5P1KT	3		
R4	RES, DEP, CAR, 10K+/-5%, 1/4W	348839	80031	CR251-4-5P10KT	3		
R5	RES, DEP, CAR, 100+/-5%, 1/4W	348771	80031	CR251-4-5P100ET	3		
R6	RES, COMP, 27+/-10%, 1/8W	266254	01121	BB2701	1		
R7	RES, COMP, 1.5K+/-5%, 1/2W	266353	01121	EB1525	2		
R8	RES, COMP, 1.5K+/-5%, 1/2W	266353	01121	EB1525	REF		
R9	RES, DEP, CAR, 1K+/-5%, 1/4W	343426	80031	CR251-4-5P1KT	REF		
R10	RES, MTL FILM, 49.9+/-1%, 1/8W	305896	91637	CMF5549R9F	1		
R11	RES, MTL FILM, 953+/-1%, 1/8W	288555	91637	CMF559530F	1		
R12	RES, DEP, CAR, 10K+/-5%, 1/4W	348839	80031	CR251-4-5P10KT	REF		
R13	RES, DEP, CAR, 20K+/-5%, 1/4W	441477	80031	CR251-4-5P20KT	1		
R14	RES, VAR, CERMET, 50K+/-10%, 1/2W	335778	89536	335778	1	1	
R15	RES, DEP, CAR, 5.1K+/-5%, 1/4W	368712	80031	CR251-4-5P5K1T	1		
R16	RES, DEP, CAR, 1K+/-5%, 1/4W	343426	80031	CR251-4-5P1KT	REF		
R17	RES, DEP, CAR, 18+/-5%, 1/4W	441428	80031	CR251-4-5P18ET	1		
R18	RES, DEP, CAR, 10+/-5%, 1/4W	340075	80031	CR251-4-5P10ET	3		
R19	RES, COMP, 3.9+/-5%, 1/2W	188490	01121	EB3R95	2		
R20	RES, MTL FILM, 301+/-1%, 1/8W	267740	91637	CMF553010F	2		
R21	RES, COMP, 1K+/-5%, 1/2W	108597	01121	EB1025	2		
R22	RES, MTL FILM, 24.3K+/-1%, 1/8W	236745	91637	CMF552432F	2		
R23	RES, MTL FILM, 10+/-0.25%, 1/4W	424192	91637	LMF1-4A100C	2		
R24	RES, MTL FILM, 100+/-0.1%, 1/8W	357400	91637	CMF55A101B	2		
R25	RES, MTL FILM, 45.3+/-1%, 1/2W	435560	91637	CMF6545R3F	4		
R26	RES, MTL FILM, 45.3+/-1%, 1/2W	435560	91637	CMF6545R3F	REF		
R27	RES, MTL FILM, 10+/-0.25%, 1/4W	424192	91637	LMF1-4A100C	REF		
R28	RES, MTL FILM, 100+/-0.1%, 1/8W	357400	91637	CMF55A101B	REF		
R29	RES, MTL FILM, 24.3K+/-1%, 1/8W	236745	91637	CMF552432F	REF		
R30	RES, COMP, 1K+/-5%, 1/2W	108597	01121	EB1025	REF		
R31	RES, MTL FILM, 301+/-1%, 1/8W	267740	91637	CMF553010F	REF		
R32	RES, COMP, 3.9+/-5%, 1/2W	188490	01121	EB39G5	REF		
R33	RES, DEP, CAR, 10+/-5%, 1/4W	340075	80031	CR251-4-5P10ET	REF		
R34	RES, DEP, CAR, 4.3+/-5%, 1/4W	441550	80031	CR251-4-5P4E3T	1		
R35	RES, DEP, CAR, 22+/-5%, 1/4W	381145	80031	CR251-4-5P22ET	1		
R36	RES, VAR, CERMET, 100+/-20%, 1/2W	193052	19701	ET50W101	1	1	
R37	RES, MTL FILM, 22.6+/-1%, 1/8W	296640	91637	CMF5522R6F	1		
R38	RES, MTL FILM, 221+/-1%, 1/8	340794	91637	CMF552210F	1		
R39	RES, MTL FILM, 2.55K+/-1%, 1/8W	325498	91637	CMF552551F	1		
R40	RES, DEP, CAR, 510+/-5%, 1/4W	441600	80031	CR251-4-5P510ET	1		

Table 603-6. Wideband Output PCB Assembly (cont)

REF DES	DESCRIPTION	FLUKE STOCK NO.	MFG SPLY CODE	MFG PART NO. OR TYPE	TOT QTY	REC QTY	NO TE
R41	RES, DEP, CAR, 10+/-5%, 1/4W	340075	80031	CR251-4-5P10ET	REF		
R42	RES, DEP, CAR, 270+/-5%, 1/4W	348789	80031	CR251-4-5P270ET	2		
R43	RES, DEP, CAR, 270+/-5%, 1/4W	348789	80031	CR251-4-5P270ET	REF		
R44	RES, DEP, CAR, 430+/-5%, 1/4W	441568	80031	CR251-4-5P430ET	1		
R45	RES, MTL FILM, 96.247+/-0.1%, 1/4W	416727	91637	CMF6096R247B	1		
R46	RES, MTL FILM, 71.151+/-0.1%, 1/8W	416735	91637	CMF5571T151B	1		
R47	RES, MTL FILM, 96.247+/-0.1%, 1/8W	416743	91637	CMF5596R247B	1		
R48	RES, MTL FILM, 61.111+/-0.1%, 1/2W	408435	91637	CMF6561R111	2		
R49	RES, MTL FILM, 247.5/-0.1%, 1/4W	408427	91637	CMF60247R5B	3		
R50	RES, MTL FILM, 61.111+/-0.1%, 1/4W	408419	91637	CMF6061R111B	4		
R51	RES, MTL FILM, 61.111+/-0.1%, 1/2W	408435	91637	CMF6561R111	REF		
R52	RES, MTL FILM, 247.5/-0.1%, 1/4W	408427	91637	CMF60247R5B	REF		
R53	RES, MTL FILM, 61.111+/-0.1%, 1/4W	408419	91637	CMF6061R111B	REF		
R54	RES, MTL FILM, 61.111+/-0.1%, 1/4W	408419	91637	CMF6061R111B	REF		
R55	RES, MTL FILM, 247.5/-0.1%, 1/4W	408427	91637	CMF60247R5B	REF		
R56	RES, MTL FILM, 61.111+/-0.1%, 1/4W	408419	91637	CMF6061R111B	REF		
R57	RES, DEP, CAR, 150+/-5%, 1/4W	343442	80031	CR251-4-5P150ET	1		
R58	RES, DEP, CAR, 10K+/-5%, 1/4W	348839	80031	CR251-4-5P10KT	REF		
R61	RES, CAR, DEP, 360+/-5%, 1/4W	352286	80031	CR251-4-5P360ET	1		
R62	RES, DEP, CAR, 75+/-5%, 1/4W	441642	80031	CR251-4-5P75ET	2		
R63	RES, DEP, CAR, 75+/-5%, 1/4W	441642	80031	CR251-4-5P75ET	REF		
R64	RES, DEP, CAR, 39+/-5%, 1/4W	340836	80031	CR251-4-5P39ET	1		
R65	RES, DEP, CAR, 1.5K+/-5%, 1/4W	343418	80031	CR251-4-5P1K5T	1		
R66	RES, MTL FILM, 178+/-1%, 1/8W	501437	91637	CMF551780	1		
R67	RES, DEP, CAR, 13K+/-5%, 1/4W	441402	80031	CR251-4-5P13KT	1		
R68	RES, DEP, CAR, 1M+/-5%, 1/4W	348987	80031	CR251-4-5P1MT	1		
R69	RES, MTL FILM, 143K+/-1%, 1/8W	291336	91637	CMF551433F	1		
R70	RES, MTL FILM, 100K+/-0.1%, 1/8W	340166	91637	CMF551003B	2		
R71	RES, MTL FILM, 100K+/-0.1%, 1/8W	340166	91637	CMF551003B	REF		
R72	IC ASSY (U8,R72,R73)	462119	89536	426119	REF		
R73	IC ASSY (U8,R72,R73)	462119	89536	426119	REF		
R74	RES, VAR, CERMET, 1K+/-10%, 1/2W	285155	11238	3601102A	1	1	
R75	RES, MTL FILM, 162K+/-1%, 1/8W	375998	91637	CMF551623F	2		
R76	RES, MTL FILM, 162K+/-1%, 1/8W	375998	91637	CMF551623F	REF		
R77	RES, MTL FILM, 432+/-1%, 1/8W	435669	91637	CMF554320F	1		
R78	RES, DEP, CAR, 47+/-5%, 1/4W	441592	80031	CR251-4-5P47ET	2		
R79	RES, VAR, CERMET, 100+/-10%, 1/2W	285130	11236	360T101A	1	1	
R80	RES, DEP, CAR, 47+/-5%, 1/4W	441592	80031	CR251-4-5P47ET	REF		
R81	RES, MTL FILM, 10K+/-1%, 1/8W	168260	91637	CMF551002F	1		
R82	RES, MTL FILM, 9.09+/-1%, 1/8W	223537	91637	CMF559092F	1		
R83	RES, MTL FILM, 40.2K+/-1%, 1/8W	235333	91637	CMF554022F	4		
R84	RES, MTL FILM, 40.2K+/-1%, 1/8W	235333	91637	CMF554022F	REF		
R85	RES, VAR, CERMET, 2K+/-10%, 1/2W	285163	89536	285163	1	1	
R86	RES, MTL FILM, 32.4K+/-1%, 1/8W	446674	91637	CMF553242F	1		
R87	RES, MTL FILM, 6.04K+/-1%, 1/8W	446682	91637	CMF556041F	1		
R88	RES, MTL FILM, 25.5K+/-1%, 1/8W	446666	91637	CMF552552F	1		
R89	RES, DEP, CAR, 100+/-5%, 1/4W	348771	80031	CR251-4-5P100ET	REF		
R90	RES, DEP, CAR, 100+/-5%, 1/4W	348771	80031	CR251-4-5P100ET	REF		
R91	RES, MTL FILM, 45.3+/-1%, 1/2W	435560	91637	CMF6545R3F	REF		
R92	RES, MTL FILM, 45.3+/-1%, 1/2W	435560	91637	CMF6545R3F	REF		

Table 603-6. Wideband Output PCB Assembly (cont)

REF DES	DESCRIPTION	FLUKE STOCK NO.	MFG SPLY CODE	MFG PART NO. OR TYPE	TOT QTY	REC QTY	N O T E
R93	RES, DEP, CAR, 3.9+/-5%, 1/4W	342600	80031	CR251-4-5P3K9T	1		
R94	RES, DEP, CAR, 4.7K+/-5%, 1/4W	348821	80031	CR251-4-5P4K7T	1		
R95	RES, MTL FILM, 40.2K+/-1%, 1/8W	235333	91637	CMF554022F	REF		
R96	RES, MTL FILM, 1.96K+/-1%, 1/8W	288423	91637	CMF551961F	1		
R97	RES, MTL FILM, 13K+/-1%, 1/8W	335539	91637	CMF551302F	1		
R98	RES, MTL FILM, 40.2K+/-1%, 1/8W	235333	91637	CMF554022F	REF		
U1	IC, LIN, OP AMP	329912	12040	LM318H	1	1	
U2	⊗ IC, C-MOS, TRIPLE 3-INPUT NAND GATE	418244	12040	MM74C10N	1	1	
U3	⊗ IC, C-MOS, HEX BUFFER/INVERTERS	381830	02735	CD4050AE	1	1	
U4	IC, TTL, LO-PWR, HEX/QUAD, D F/F	393207	01295	SN74LS174	1	1	
U5	IC, TTL, BUFFERS & INTERFACE GATES	407593	01295	SN7406N	1	1	
U6	IC, OP AMP, LO-BIAS	413732	12040	LM308N	1	1	
U7	IC, OP AMP	413740	12040	LM307N	1	1	
U8	IC ASSY (U8,R72,R73)	462119	89536	426119	1	1	
VR1	DIODE, ZENER, 13V	110726	07910	IN964B	1	1	
VR2	DIODE, ZENER, 8.2V	386771	07910	IN756A	7	2	
VR3	DIODE, ZENER, 8.2V	386771	07910	IN756A	REF		
VR4	DIODE, ZENER, 8.2V	386771	07910	IN756A	REF		
VR5	DIODE, ZENER, 8.2V	386771	07910	IN756A	REF		
VR6	DIODE, ZENER, 8.2V	386771	07910	IN756A	REF		
VR7	DIODE, ZENER, 8.2V	386771	07910	IN756A	REF		
VR8	DIODE, ZENER, 8.2V	386771	07910	IN756A	REF		
VR9	DIODE, ZENER, 7.5V	256446	07910	IN755A	1	1	
VR10	DIODE, ZENER, 5.6V	277236	07910	IN752A	1	1	
VR11	DIODE, ZENER, 10V	246611	07910	IN961A	1	1	
XQ4-1	SOCKET, XSTR	285262	71785	133-23-92-045	7		
XQ4-2	HEATSINK, ROUND (NOT SHOWN)	407262	13103	1130	7		
XQ5-1	SOCKET, XSTR	285262	71785	133-23-92-045	REF		
XQ5-2	HEATSINK, ROUND (NOT SHOWN)	407262	13103	1130	REF		
XQ6-1	SOCKET, XSTR	285262	71785	133-23-92-045	REF		
XQ6-2	HEATSINK, ROUND (NOT SHOWN)	407262	13103	1130	REF		
XQ7-1	SOCKET, XSTR	285262	71785	133-23-92-045	REF		
XQ7-2	HEATSINK, ROUND (NOT SHOWN)	407262	13103	1130	REF		
XQ8-1	SOCKET, XSTR	285262	71785	133-23-92-045	REF		
XQ8-2	HEATSINK, ROUND (NOT SHOWN)	407262	13103	1130	REF		
XQ10-1	SOCKET, XSTR	285262	71785	133-23-92-045	REF		
XQ10-2	HEATSINK, ROUND (NOT SHOWN)	407262	13103	1130	REF		
XQ11-1	SOCKET, XSTR	285262	71785	133-23-92-045	REF		
XQ11-2	HEATSINK, ROUND (NOT SHOWN)	407262	13103	1130	REF		
XU8	SOCKET, IC, 14-PIN	370304	91506	314-AG39D	1		

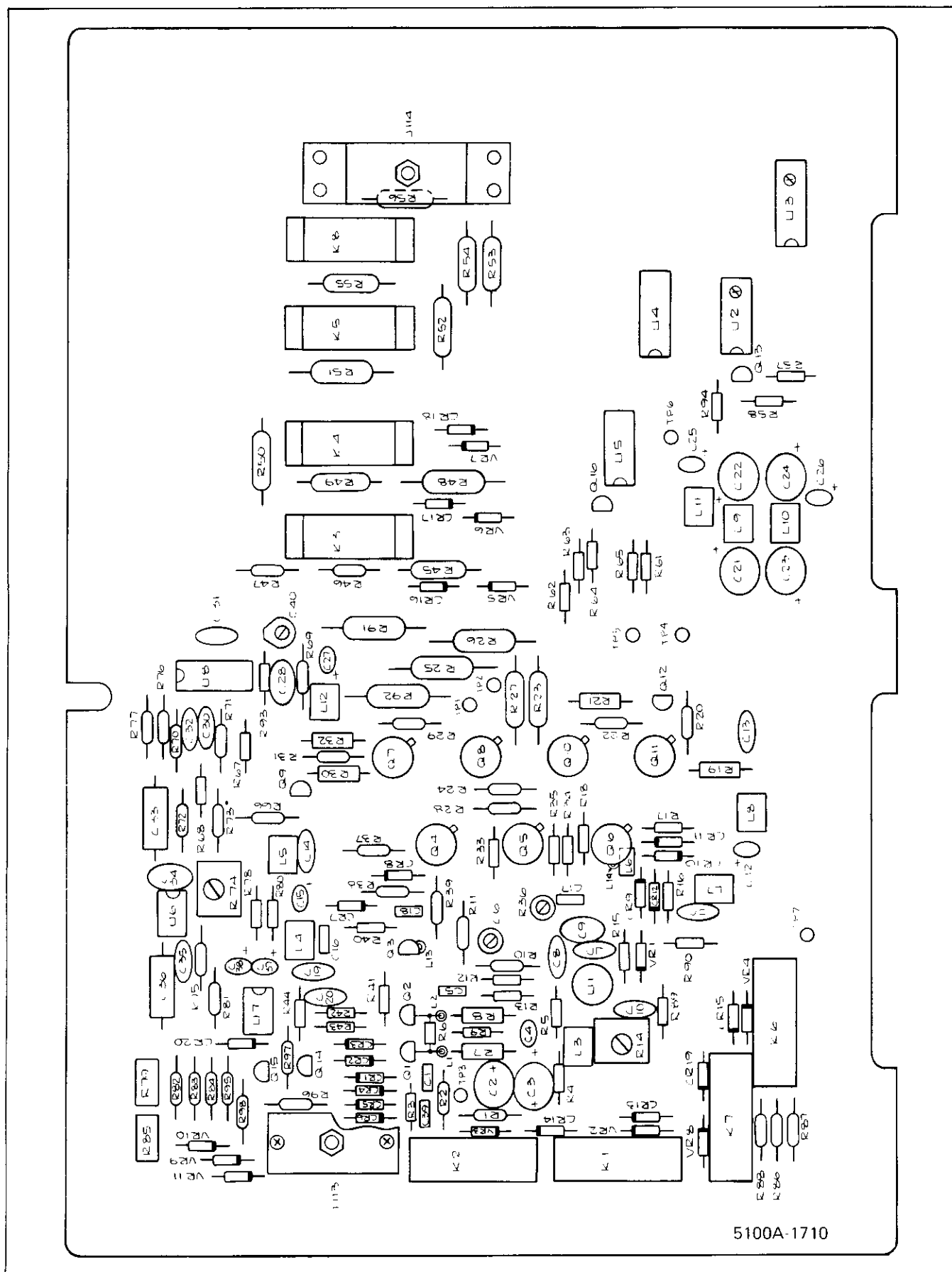

Figure 603-9. Wideband Output PCB Assembly

Table 603-7. Wideband Oscillator PCB Assembly

REF DES	DESCRIPTION	FLUKE STOCK NO.	MFG SPLY CODE	MFG PART NO. OR TYPE	TOT QTY	REC QTY	NO TE
A13	② WIDEBAND OSCILLATOR PCB ASSEMBLY FIGURE 603-10 (5100A-4120)	ORDER	BY	OPTION -03			
C1	CAP, CER, 39 PF +/-5%, 1000V	417410	72982	858-000-R2G-390J	3		
C2	CAP, TA, 10 UF +/-20%, 20V	330662	56289	196D106X0020KA1	39		
C3	CAP, CER, 0.01 UF +/-20%, 100V	149153	56289	C023B101F103M	8		
C4	CAP, TA, 10 UF +/-20%, 20V	330662	56289	196D106X0020KA1	REF		
C6	CAP, TA, 10 UF +/-20%, 20V	330662	56289	196D106X0020KA1	REF		
C7	CAP, TA, 10 UF +/-20%, 20V	330662	56289	196D106X0020KA1	REF		
C8	CAP, TA, 10 UF +/-20%, 20V	330662	56289	196D106X0020KA1	REF		
C9	CAP, TA, 10 UF +/-20%, 20V	330662	56289	196D106X0020KA1	REF		
C10	CAP, MICA, 33 PF +/-5%, 500V	160317	72136	DM15330J	1		
C11	CAP, CER, 300 PF +/-10%, 500V	105734	71590	BB60301KW7W	1		
C12	CAP, TA, 10 UF +/-20%, 20V	330662	56289	196D106X0020KA1	REF		
C13	CAP, TA, 10 UF +/-20%, 20V	330662	56289	196D106X0020KA1	REF		
C14	CAP, TA, 10 UF +/-20%, 20V	330662	56289	196D106X0020KA1	REF		
C15	CAP, POLYSTR FILM, 0.033 UF +/-10%, 250V	234492	73445	C280MAE/A33K	1		
C16	CAP, MICA, 490 PF +/-5%, 500V	148437	72136	DM15F491J	3		
C17	CAP, MICA, 18 PF +/-5%, 5000V	266585	72136	DM15C180J	1		
C18	CAP, MICA, 1200 PF +/-5%, 500V	148379	72136	DM19F122J	2		
C19	CAP, MICA, 490 PF +/-5%, 500V	148437	72136	DM15F491J	REF		
C20	CAP, MICA, 1200 PF +/-5%, 500V	148379	72136	DM19F122J	REF		
C21	CAP, MICA, 360 PF +/-5%, 500V	325878	72136	DM15F361J	1		
C22	CAP, MICA, 1000 PF +/-5%, 500V	148387	72136	DM19F102J	1		
C23	CAP, CER, 0.01 UF +/-20%, 100V	149153	56289	C023B101F103M	REF		
C25	CAP, TA, 10 UF +/-20%, 20V	330662	56289	196D106X0020KA1	REF		
C26	CAP, TA, 10 UF +/-20%, 20V	330662	56289	196D106X0020KA1	REF		
C27	CAP, CER, 39 PF +/-5%, 1000V	417410	72982	858-000-R2G-390J	REF		
C28	CAP, MICA, 510 PF +/-5%, 500V	148411	72136	DM19F511J	1		
C29	CAP, CER, 0.01 UF +/-20%, 100V	149153	56289	C023B101F103M	REF		
C30	CAP, TA, 10 UF +/-20%, 20V	330662	56289	196D106X0020KA1	REF		
C31	CAP, CER, 0.01 UF +/-20%, 100V	149153	56289	C023B101F103M	REF		
C32	CAP, TA, 10 UF +/-20%, 20V	330662	56289	196D106X0020KA1	REF		
C33	CAP, MICA, 22 PF +/-5%, 500V	148551	72136	DM15C220J	4		
C34	CAP, MICA, 22 PF +/-5%, 500V	148551	72136	DM15C220J	REF		
C35	CAP, MICA, 430 PF +/-5%, 500V	177980	72136	DM15F431J	1		
C36	CAP, CER, 39 PF +/-5%, 1000V	417410	72982	858-000-R2G-390J	REF		
C37	CAP, MICA, 490 PF +/-5%, 500V	148437	72136	DM15F491J	REF		
C38	CAP, TA, 10 UF +/-20%, 20V	330662	56289	196D106X0020KA1	REF		
C39	CAP, MICA, 100 PF +/-1%, 500V	170415	72136	DM15F111F	1		
C40	CAP, MICA, 5 PF +/-0.5 PF, 500V	148577	72136	DM15C050D	3		
C41	CAP, MICA, 150 +/-55, 500V	148478	72136	DM15F151J	1		
C42	CAP, MICA, 12 PF +/-5%, 500V	175224	72136	DM15C120J	3		
C43	CAP, MICA, 100 PF +/-5%, 500V	148494	72136	DM15F101J	1		
C44	CAP, CER, 0.05 UF +/-20%, 100V	149161	56289	55C23A1	2		
C45	CAP, CER, 0.05 UF +/-20%, 100V	149161	56289	55C23A1	REF		
C46	CAP, TA, 10 UF +/-20%, 20V	330662	56289	196D106X0020KA1	REF		
C47	CAP, TA, 10 UF +/-20%, 20V	330662	56289	196D106X0020KA1	REF		
C48	CAP, TA, 10 UF +/-20%, 20V	330662	56289	196D106X0020KA1	REF		
C49	CAP, TA, 10 UF +/-20%, 20V	330662	56289	196D106X0020KA1	REF		

Table 603-7. Wideband Oscillator PCB Assembly (cont)

ITEM NO.	DESCRIPTION	FLUKE STOCK NO.	MFG SPLY CODE	MFG PART NO. OR TYPE	TOT QTY	REC QTY	USE CDE
C50	CAP, TA, 10 UF +/-20%, 20V	330662	56289	196D106X0020KA1	REF		
C51	CAP, TA, 4.7 UF +/-20%, 25V	161943	56289	196D475X0015KA1	2		
C52	CAP, TA, 4.7 UF +/-20%, 25V	161943	56289	196D475X0015KA1	REF		
C53	CAP, MICA, 51 PF +/-5%, 500V	277210	72136	DM15E510J	1		
C54	CAP, MICA, 12 PF +/-5%, 500V	175224	72136	DM15C120J	REF		
C55	CAP, MICA, 56 PF +/-5%, 500V	148528	72136	DM15F560J	1		
C56	CAP, TA, 68 UF +/-20%, 15V	193615	56289	196D686X0015TE4	2		
C57	CAP, MICA, 4 PF +/-0.5 PF, 500V	190397	72136	DM15C040D	1		
C58	CAP, MICA, 10 PF +/-10%, 500V	175216	72136	DM15C100K	2		
C59	CAP, MICA, 5 PF +/-0.5 PF, 500V	148577	72136	DM15C050D	REF		
C60	CAP, TA, 68 UF +/-20%, 15V	193615	56289	196D686X0015TE4	REF		
C61	CAP, TA, 10 UF +/-20%, 20V	330662	56289	196D106X0020KA1	REF		
C62	CAP, MICA, 130 PF +/-5%, 500V	266205	72136	DM1F131J	1		
C63	CAP, MICA, 43 PF +/-5%, 500V	277202	72136	DME15430J	1		
C64	CAP, MICA, 270 +/-5%, 500V	148452	72136	DM15F271J	1		
C65	CAP, MICA, 22 PF +/-5%, 500V	148551	72136	DM15C220J	REF		
C66	CAP, MICA, 220 PF +/-5%, 500V	170423	72136	DM15F221J	1		
C67	CAP, TA, 10 UF +/-20%, 20V	330662	56289	196D106X0020KA1	REF		
C68	CAP, TA, 10 UF +/-20%, 20V	330662	56289	196D106X0020KA1	REF		
C69	CAP, MICA, 10 PF +/-10%, 500V	175216	72136	DM15C100K	REF		
C70	CAP, MICA, 5 PF +/-0.5 PF, 500V	148577	72136	DM15C050D	REF		
C71	CAP, TA, 10 UF +/-20%, 20V	330662	56289	196D106X0020KA1	REF		
C72	CAP, TA, 10 UF +/-20%, 20V	330662	56289	196D106X0020KA1	REF		
C73	CAP, TA, 10 UF +/-20%, 20V	330662	56289	196D106X0020KA1	REF		
C76	CAP, CER, 0.005 UF +/-20%, 100V	175232	56289	C023B101E502M	1		
C77	CAP, TA, 10 UF +/-20%, 20V	330662	56289	196D106X0020KA1	REF		
C78	CAP, TA, 10 UF +/-20%, 20V	330662	56289	196D106X0020KA1	REF		
C79	CAP, TA, 10 UF +/-20%, 20V	330662	56289	196D106X0020KA1	REF		
C80	CAP, TA, 10 UF +/-20%, 20V	330662	56289	196D106X0020KA1	REF		
C81	CAP, TA, 10 UF +/-20%, 20V	330662	56289	196D106X0020KA1	REF		
C82	CAP, TA, 10 UF +/-20%, 20V	330662	56289	196D106X0020KA1	REF		
C83	CAP, TA, 10 UF +/-20%, 20V	330662	56289	196D106X0020KA1	REF		
C84	CAP, TA, 10 UF +/-20%, 20V	330662	56289	196D106X0020KA1	REF		
C85	CAP, TA, 22 UF +/-20%, 25V	357780	56289	196D226X0025PE4	1		
C86	CAP, CER, 1200 PF +/-20%, 100V	358283	72982	8121-A100-W5R-122M	1		
C87	CAP, TA, 10 UF +/-20%, 20V	330662	56289	196D106X0020KA1	REF		
C88	CAP, TA, 10 UF +/-20%, 20V	330662	56289	196D106X0020KA1	REF		
C89	CAP, TA, 10 UF +/-20%, 20V	330662	56289	196D106X0020KA1	REF		
C90	CAP, CER, 0.01 UF +/-20%, 100V	149153	56289	C023B101F103M	REF		
C91	CAP, CER, 0.01 UF +/-20%, 100V	149153	56289	C023B101F103M	REF		
C92	CAP, TA, 10 UF +/-20%, 20V	330662	56289	196D106X0020KA1	REF		
C93	CAP, TA, 10 UF +/-20%, 20V	330662	56289	196D106X0020KA1	REF		
C94	CAP, CER, 0.01 UF +/-20%, 100V	149153	56289	C023B101F103M	REF		
C95	CAP, CER, 0.01 UF +/-20%, 100V	149153	56289	C023B101F103M	REF		
C96	CAP, TA, 10 UF +/-20%, 20V	330662	56289	196D106X0020KA1	REF		
C97	CAP, MICA, 47 PF +/-5%, 500V	148536	72136	DM15E470J	1		
C98	CAP, MICA, 22 PF +/-5%, 500V	148551	72136	DM15C220J	REF		
C99	CAP, MICA, 12 PF +/-5%, 500V	175224	72136	DM15C120J	REF		
CR1	DIODE, VOL-VAR TUNING	363812	04713	MV109	1		1
CR2	DIODE, SI, HI-SPEED SWITCHING	203323	07910	IN4448	2		1

Table 603-7. Wideband Oscillator PCB Assembly (cont)

REF DES	DESCRIPTION	FLUKE STOCK NO.	MFG SPLY CODE	MFG PART NO. OR TYPE	TOT QTY	REC QTY	N O T E
CR3	DIODE, SI, SCHKY, BARRIER SWITCHING	313247	28480	5082-6264	1		1
CR4	DIODE, SI, RECT	116111	05277	IN4817	1		1
CR5	DIODE, SI, HI-SPEED SWITCHING	203323	07910	IN4448	REF		
H1	SCREW, PHP, SEMS (NOT SHOWN)	185918	89536	185918	2		
H2	SPACER, STANDOFF	340547	89536	340547	5		
J123	CONN, MALE, BULKHEAD RECPT	207639	02660	27-875	1		
K1	RELAY, DRY REED	404590	71707	CR4503	1		
L1	CHOKE, 6-TURN	320911	89536	320911	23		
L2	CHOKE, 6-TURN	320911	89536	320911	REF		
L3	INDUCTOR, SUB-MINI	363184	24759	MR-6800	3		
L4	INDUCTOR, SUB-MINI	363184	24759	MR-6800	REF		
L5	INDUCTOR, SUB-MINI	363184	24759	MR-6800	REF		
L6	CHOKE, 6-TURN	320911	89536	320911	REF		
L7	CHOKE, 6-TURN	320911	89536	320911	REF		
L8	CHOKE, 6-TURN	320911	89536	320911	REF		
L9	CHOKE, 6-TURN	320911	89536	320911	REF		
L10	CHOKE, 6-TURN	320911	89536	320911	REF		
L11	COIL, RF	385850	89536	385850	6		
L12	CHOKE, RF	174730	72259	WEE-10	1		
L13	CHOKE, 6-TURN	320911	89536	320911	REF		
L14	COIL, RF	385850	89536	385850	REF		
L15	COIL, RF	385850	89536	385850	REF		
L16	INDUCTOR, SUB-MINI	329664	24759	MR-0.47	2		
L17	INDUCTOR, SUB-MINI	329664	24759	MR-0.47	REF		
L18	CHOKE, 6-TURN	320911	89536	320911	REF		
L19	CHOKE, 6-TURN	320911	89536	320911	REF		
L20	CHOKE, 6-TURN	320911	89536	320911	REF		
L21	INDUCTOR, SUB-MINI	413864	24759	MR-3.9	1		
L22	CHOKE, 6-TURN	320911	89536	320911	REF		
L23	COIL, RF	385850	89536	385850	REF		
L24	INDUCTOR, SUB-MINI	413856	24759	MR-1.5	1		
L25	CHOKE, 6-TURN	320911	89536	320911	REF		
L26	CHOKE, 6-TURN	320911	89536	320911	REF		
L27	CHOKE, 6-TURN	320911	89536	320911	REF		
L28	CHOKE, 6-TURN	320911	89536	320911	REF		
L29	CHOKE, 6-TURN	320911	89536	320911	REF		
L30	INDUCTOR, SUB-MINI	363192	24759	MR-27,000	1		
L31	CHOKE, 6-TURN	320911	89536	320911	REF		
L32	CHOKE, 6-TURN	320911	89536	320911	REF		
L33	FERRITE TUBE, CHOKE, CORE	321182	02114	56-590-65-4B	1		
L35	CHOKE, 6-TURN	320911	89536	320911	REF		
L36	CHOKE, 6-TURN	320911	89536	320911	REF		
L37	CHOKE, 6-TURN	320911	89536	320911	REF		
L38	CHOKE, 6-TURN	320911	89536	320911	REF		
L39	INDUCTOR, SUB-MINI	413880	24759	MR-2.2	1		
MP1	CONNECTOR, MTG. PLATE (TO J123)	438127	89536	438127	1		
MP2	FENCE	450031	89536	450031	1		
Q1	XSTR, SI, NPN	248351	04713	MPS918	7		2
Q2	XSTR, SI, NPN	248351	04713	MPS918	REF		
Q3	XSTR, SI, NPN	248351	04713	MPS918	REF		

Table 603-7. Wideband Oscillator PCB Assembly (cont)

REF DES	DESCRIPTION	FLUKE STOCK NO.	MFG SPLY CODE	MFG PART NO. OR TYPE	TOT QTY	REC QTY	NOTE
Q4	XSTR, SI, PNP	226290	04713	MPS3640	6		1
Q5	XSTR, SI, NPN	248351	04713	MPS918	REF		
Q6	XSTR, SI, PNP	226290	04713	MPS3640	REF		
Q7	XSTR, SI, PNP	229898	04713	MPS6522	1		1
Q8	XSTR, SI, NPN	218396	04713	2N3904	1		1
Q9	XSTR, SI, NPN	248351	04713	MPS918	REF		
Q10	XSTR, SI, NPN	248351	04713	MPS918	REF		
Q11	XSTR, SI, NPN	248351	04713	MPS918	REF		
Q13	XSTR, SI, PNP	343012	12040	PN4258	4		1
Q14	XSTR, SI, PNP	343012	12040	PN4258	REF		
Q15	XSTR, SI, NPN	453431	04713	SPS7503	4		1
Q16	XSTR, SI, NPN	453431	04713	SPS7503	REF		
Q17	XSTR, SI, PNP	343012	12040	PN4258	REF		
Q18	XSTR, SI, NPN	453431	04713	SPS7503	REF		
Q19	XSTR, SI, NPN	453431	04713	SPS7503	REF		
Q20	XSTR, SI, PNP	343012	12040	PN4258	REF		
Q21	XSTR, SI, NPN	346916	04713	2N2219A	1		1
Q22	XSTR, SI, PNP	226290	04713	MPS3640	REF		
Q23	XSTR, SI, PNP	226290	04713	MPS3640	REF		
Q24	XSTR, SI, PNP	226290	04713	MPS3640	REF		
Q25	XSTR, SI, PNP	226290	04713	MPS3640	REF		
R1	RES, DEP. CAR, 10K +/-5%, 1/4W	348839	80031	CR251-4-5P10KT	4		
R2	RES, DEP. CAR, 100 +/-5%, 1/4W	348771	80031	CR251-4-5P100ET	10		
R3	RES, DEP. CAR, 1.2K +/-5%, 1/4W	441378	80031	CR251-4-5P1K2T	4		
R4	RES, DEP. CAR, 1.2K +/-5%, 1/4W	441378	80031	CR251-4-5P1K2T	REF		
R5	RES, DEP. CAR, 3K +/-5%, 1/4W	441527	80031	CR251-4-5P3KT	2		
R6	RES, DEP. CAR, 270 +/-5%, 1/4W	348789	80031	CR251-4-5P270ET	4		
R7	RES, DEP. CAR, 360 +/-5%, 1/4W	352286	80031	CR251-4-5P360ET	3		
R8	RES, DEP. CAR, 62 +/-1%, 1/4W	441634	80031	CR251-4-5P62ET	1		
R9	RES, MTL. FILM, 750 +/-1%, 1/8W	312801	91637	CMF557500F	2		
R10	RES, MTL. FILM, 3.83K +/-1%, 1/8W	235143	91637	CMF553831F	1		
R11	RES, MTL. FILM, 5.49K +/-1%, 1/8W	334565	91637	CMF555491F	1		
R12	RES, MTL. FILM, 9.09 +/-1%, 1/8W	221663	91627	CMF559092F	1		
R13	RES, DEP. CAR, 100 +/-5%, 1/4W	348771	80031	CR251-4-5P100ET	REF		
R14	RES, DEP. CAR, 47 K +/-5%, 1/4W	348896	80031	CR251-4-5P47KT	1		
R15	RES, MTL. FILM, 1.78K +/-1%, 1/2W	247296	91637	CMF651781F	1		
R16	RES, DEP. CAR, 750 +/-5%, 1/4W	441659	80031	CR251-4-5P750ET	1		
R17	RES, DEP. CAR, 3.9K +/-5%, 1/4W	342600	80031	CR251-4-5P39KT	1		
R18	RES, DEP. CAR, 2K +/-5%, 1/4W	441469	80031	CR251-4-5P2KT	2		
R19	RES, DEP. CAR, 560K +/-5%, 1/4W	342642	80031	CR251-4-5P560KT	1		
R20	RES, DEP. CAR, 100 +/-5%, 1/4W	348771	80031	CR251-4-5P100ET	REF		
R21	RES, DEP. CAR, 100 +/-5%, 1/4W	348771	80031	CR251-4-5P100ET	REF		
R22	RES, DEP. CAR, 1.2K +/-5%, 1/4W	441378	80031	CR251-4-5P1K2T	REF		
R23	RES, DEP. CAR, 1.2K +/-5%, 1/4W	441378	80031	CR251-4-5P1K2T	REF		
R24	RES, DEP. CAR, 360 +/-5%, 1/4W	352286	80031	CR251-4-5P360ET	REF		
R25	RES, DEP. CAR, 3K +/-5%, 1/4W	441527	80031	CR251-4-5P3KT	REF		
R26	RES, DEP. CAR, 270 +/-5%, 1/4W	348789	80031	CR251-4-5P270ET	REF		
R27	RES, DEP. CAR, 10K +/-5%, 1/4W	348839	80031	CR251-4-5P10KT	REF		
R28	RES, DEP. CAR, 4.7K +/-5%, 1/4W	348821	80031	CR251-4-5P47KT	1		
R29	RES, DEP. CAR, 10K +/-5%, 1/4W	348839	80031	CR251-4-5P10KT	REF		

Table 603-7. Wideband Oscillator PCB Assembly (cont)

REF DES	DESCRIPTION	FLUKE STOCK NO.	MFG SPLY CODE	MFG PART NO. OR TYPE	TOT QTY	REC QTY	NOTE
R30	RES, DEP, CAR, 10K +/-5%, 1/4W	348839	80031	CR251-4-5P10KT	REF		
R31	RES, DEP, CAR, 150 +/-5%, 1/4W	343442	80031	CR251-4-5P150ET	2		
R32	RES, DEP, CAR, 150 +/-5%, 1/4W	343442	80031	CR251-4-5P150ET	REF		
R33	RES, MTL, FILM, 3.01K +/-1%, 1/8W	312645	91637	CMF553011F	1		
R34	RES, MTL, FILM, 182 +/-1%, 1/8W	289579	91637	CMF551820F	2		
R35	RES, MTL, FILM, 4.02K +/-1%, 1/8W	235325	91637	CMF554021F	1		
R36	RES, VAR, CERMET, 500 +/-10%, 1/2W	325613	89536	325613	1	1	
R37	RES, MTL, FILM, 324 +/-1%, 1/8W	443010	91637	CMF553240F	1		
R38	RES, MTL, FILM, 182 +/-1%, 1/8W	289579	91637	CMF551820F	REF		
R39	RES, MTL, FILM, 49.9 +/-1%, 1/8W	305896	91637	CMF5549R9F	5		
R40	RES, MTL, FILM, 49.9 +/-1%, 1/8W	305896	91637	CMF5549R9F	REF		
R41	RES, MTL, FILM, 49.9 +/-1%, 1/8W	305896	91637	CMF5549R9F	REF		
R42	RES, DEP, CAR, 2K +/-5%, 1/4W	441469	80031	CR251-4-5P2KT	REF		
R45	RES, DEP, CAR, 100 +/-5%, 1/4W	348771	80031	CR251-4-5P100ET	REF		
R46	RES, MTL, FILM, 422 +/-1%, 1/8W	288506	91637	CMF554220F	1		
R47	RES, MTL, FILM, 49.9 +/-1%, 1/8W	305896	91637	CMF5549R9F	REF		
R48	RES, DEP, CAR, 5.1 +/-5%, 1/4W	441287	80031	CR251-4-5P5E1T	2		
R49	RES, MTL, FILM, 49.9 +/-1%, 1/8W	305896	91637	CMF5549R9F	REF		
R50	RES, MTL, FILM, 750 +/-1%, 1/8W	312801	91637	CMF557500F	REF		
R51	RES, MTL, FILM, 649 +/-1%, 1/8W	309955	91637	CMF556490F	1		
R52	RES, MTL, FILM, 732 +/-1%, 1/8W	294884	91637	CMF557320F	2		
R53	RES, VAR, CERMET, 20 +/-20%, 1/2W	275727	11236	360T200B	1	1	
R54	RES, MTL, FILM, 634 +/-1%, 1/8W	223560	91637	CMF556340F	1		
R55	RES, MTL, FILM, 301 +/-1%, 1/8W	267740	91637	CMF553010F	1		
R56	RES, DEP, CAR, 10 +/-5%, 1/4W	340075	80031	CR251-4-5P10ET	1		
R57	RES, DEP, CAR, 240 +/-5%, 1/4W	376624	80031	CR251-4-5P240ET	1		
R58	RES, MTL, FILM, 100 +/-1%, 1/8W	168195	91637	CMF55A100F	2		
R59	RES, VAR, CERMET, 1K +/-20%, 1/2W	193060	19701	ET50W102	1		
R60	RES, MTL, FILM, 100 +/-1%, 1/8W	168195	91637	CMF55A100F	REF		
R61	RES, MTL, FILM, 453 +/-1%, 1/8W	267393	91637	CMF554530F	1		
R62	RES, DEP, CAR, 270 +/-5%, 1/4W	348789	80031	CR251-4-5P270ET	REF		
R63	RES, DEP, CAR, 1.3K +/-5%, 1/4W	441394	80031	CR251-4-5P-1K3T	4		
R64	RES, DEP, CAR, 4.7 +/-5%, 1/4W	441584	80031	CR251-4-5P4E7T	2		
R65	RES, DEP, CAR, 1.3K +/-5%, 1/4W	441394	80031	CR251-4-5P-1K3T	REF		
R66	RES, DEP, CAR, 100 +/-5%, 1/4W	348771	80031	CR251-4-5P100ET	REF		
R67	RES, COMP, 680 +/-5%, 1/2W	178392	01121	EB6815	3		
R68	RES, DEP, CAR, 500 +/-5%, 1/4W	441600	80031	CR251-4-5P500ET	1		
R69	RES, DEP, CAR, 5.6 +/-5%, 1/4W	441618	80031	CR251-4-5P5E6T	2		
R70	RES, DEP, CAR, 100 +/-5%, 1/4W	348771	80031	CR251-4-5P100ET	REF		
R71	RES, DEP, CAR, 100 +/-5%, 1/4W	348771	80031	CR251-4-5P100ET	REF		
R72	RES, DEP, CAR, 1.3K +/-5%, 1/4W	441394	80031	CR251-4-5P-1K3T	REF		
R73	RES, DEP, CAR, 4.7 +/-5%, 1/4W	441584	80031	CR251-4-5P4E7T	REF		
R74	RES, DEP, CAR, 1.3K +/-5%, 1/4W	441394	80031	CR251-4-5P-1K3T	REF		
R75	RES, DEP, CAR, 1K +/-5%, 1/4W	343426	80031	CR251-4-5P1KT	1		
R76	RES, COMP, 680 +/-5%, 1/2W	178392	01121	EB6815	REF		
R77	RES, MTL, FILM, 732 +/-1%, 1/8W	294884	91637	CMF557320F	REF		
R78	RES, DEP, CAR, 5.6 +/-5%, 1/4W	441618	80031	CR251-4-5P5E6T	REF		
R79	RES, MTL, FILM, 150 +/-1%, 1/8W	448555	91637	CMF551500F	2		
R80	RES, COMP, 680 +/-5%, 1/2W	178392	01121	EB6815	REF		
R81	RES, MTL, FILM, 150 +/-1%, 1/8W	448555	91637	CMF551500F	REF		

Table 603-7. Wideband Oscillator PCB Assembly (cont)

REF DES	DESCRIPTION	FLUKE STOCK NO.	MFG SPLY CODE	MFG PART NO. OR TYPE	TOT QTY	REC QTY	NO TE
R82	RES, DEP. CAR, 1.8K +/-5%, 1/4W	441444	80031	CR251-4-5P1K8T	1		
R83	RES, MTL. FILM, 10K +/-1%, 1/8W	168260	91637	CMF551002F	1		
R85	RES, MTL. FILM, 3.5K +/-1%, 1/8W	226217	80031	CMF553571F	1		
R86	RES, DEP. CAR, 5.1 +/-5%, 1/4W	441287	80031	CR251-4-5P5E1T	REF		
R87	RES, DEP. CAR, 200 +/-5%, 1/4W	441451	80031	CR251-4-5P200ET	3		
R89	RES, DEP. CAR, 4.3K +/-5%, 1/4W	441576	80031	CR251-4-5P4K3T	1		
R90	RES, COMP, 510 +/-5%, 1/2W	108951	01121	EB5115	1		
R92	RES, DEP. CAR, 30K +/-5%, 1/4W	368753	80031	CR251-4-5P30KT	2		
R93	RES, DEP. CAR, 330 +/-5%, 1/4W	368720	80031	CR251-4-5P330ET	2		
R94	RES, DEP. CAR, 160 +/-55, 1/4W	441410	80031	CR251-4-5P160ET	2		
R95	RES, DEP. CAR, 100 +/-5%, 1/4W	348771	80031	CR251-4-5P100ET	REF		
R96	RES, DEP. CAR, 200 +/-5%, 1/4W	441451	80031	CR251-4-5P200ET	REF		
R97	RES, DEP. CAR, 20K +/-5%, 1/4W	441447	80031	CR251-4-5P20KT	2		
R98	RES, DEP. CAR, 30K +/-5%, 1/4W	368753	80031	CR251-4-5P30KT	REF		
R99	RES, DEP. CAR, 330 +/-5%, 1/4W	368720	80031	CR251-4-5P330ET	REF		
R100	RES, DEP. CAR, 160 +/-55, 1/4W	441410	80031	CR251-4-5P160ET	REF		
R101	RES, DEP. CAR, 100 +/-5%, 1/4W	348771	80031	CR251-4-5P100ET	REF		
R102	RES, DEP. CAR, 200 +/-5%, 1/4W	441451	80031	CR251-4-5P200ET	REF		
R103	RES, DEP. CAR, 20K +/-5%, 1/4W	441447	80031	CR251-4-5P20KT	REF		
R104	RES, DEP. CAR, 270 +/-5%, 1/4W	348789	80031	CR251-4-5P270ET	REF		
R105	RES, DEP. CAR, 360 +/-5%, 1/4W	352286	80031	CR251-4--5P360ET	REF		
R106	RES, DEP. CAR, 2 +/-5%, 1/4W	442053	80031	CR251-4-5-P2ET	1		
T1	COIL, RF	385850	89536	385850	REF		
T2	COIL, RF	385850	89536	385850	REF		
U2	IC, TTL, LO-PWR, DUAL J-K, F/F	414029	01295	SN74LS112N	1		1
U3	IC, TTL, DUAL 4-BIT DECADE & BINARY CNT	402552	01295	SN74390N	1		1
U4	IC, TTL, PHADE FREQUENCY DETECTOR	320721	04713	MC4044P	1		1
U5	IC, OP, AMP	271502	12040	LM301A	1		1
U6	IC, TTL, TRIPLE, 3-INPUT, POS NAND GATES	363457	01295	SN74311N	2		1
U7	⊗ IC, C-MOS, DUAL, 4-INPUT, NAND GATE	429407	12040	MM74C20N	1		1
U9	⊗ IC, C-MOS, HEX, BUFFER/INVERTERS	381830	02735	CD4050AE	1		1
U11	IC, TTL, LO-PWR, HEX/QUAD, D-TYPE F/F	393207	01295	SN74LS174N	2		1
U12	IC, TTL, LO-PWR, HEX/QUAD, D-TYPE F/F	393207	01295	SN74LS174N	REF		
U13	IC, TTL, 50 MHZ, DECADE COUNTER	320754	01295	SN74196N	1		1
U14	IC, TTL, 30 MHZ, PST DECADE	393256	01295	SN74LS196N	2		1
U15	IC, TTL, 30 MHZ, PST DECADE	393256	01295	SN74LS196N	REF		
U17	IC, TTL, TRIPLE, 3-INPUT, POS NAND GATES	363457	01295	SN74311N	REF		
U18	IC, TTL, DUAL, J-K EDGE TRIG, F/F	293100	01295	SN74H106N	1		1
U19	IC, TTL, DUAL, J-K EDGE-TRIG, F/F	363440	01295	SN74S112N	1		1
U20	IC, LIN, BALANCED MODULATOR/DEMOMULATOR	344036	04713	MC1496L	1		1
U21	IC, LIN, 5-XSTR, ARRAY	248906	02735	CA4036	1		1
U23	IC, HEX, INVERTER, BUFFER/DRIVER	407593	01295	SN7406N	1		1
VR1	DIODE, ZENER 10V	246611	07910	IN961B	3		1
VR2	DIODE, ZENER 10V	246611	07910	IN961B	REF		
VR3	DIODE, ZENER, 4.3V	180455	07910	IN749A	1		1
VR4	DIODE, ZENER, 6.8V	342527	07910	IN754B			
VR5	DIODE, ZENER 10V	246611	07910	IN961B	REF		
VR6	DIODE, ZENER, 5.1	159798	07910	IN751A	1		1
VR7	DIODE, ZENER, 15V	266601	07910	IN965B	2		1
VR8	DIODE, ZENER, 15V	266601	07910	IN965B	REF		
XQ21A	HEATSINK, XSTR	104646	05820	207-AB	1		
XQ21B	TRANSIPAD	152207	07047	10123DAP	1		

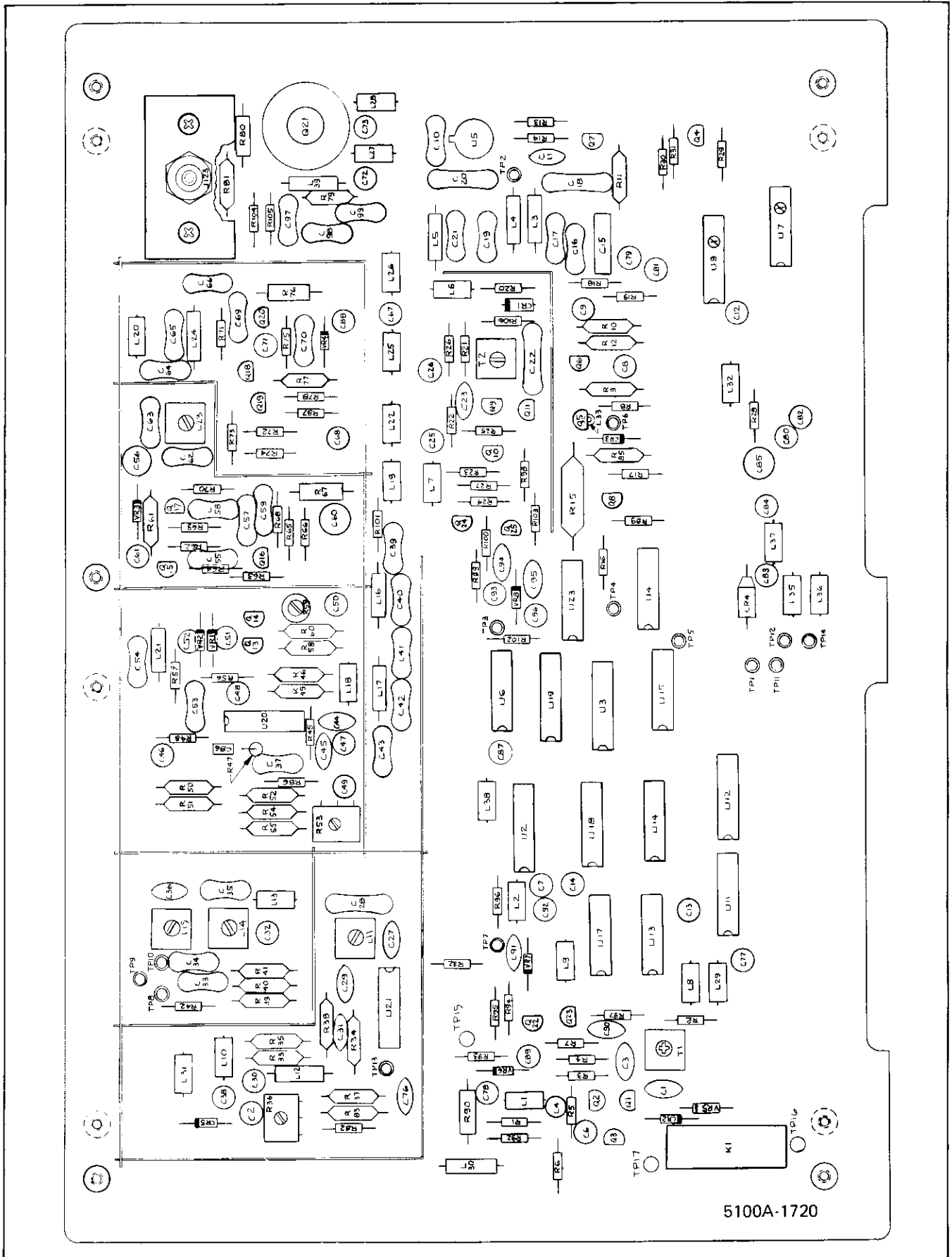

5100A-1720

Figure 603-10. Wideband Oscillator PCB Assembly

-05 Option IEEE 488-1975 Standard Interface

605-1. INTRODUCTION

605-2. The IEEE 488-1875 Interface places the 5100 Series B Calibrator on an IEEE Bus, allowing it to be programmed through a system controller. The instrument outputs are available to the bus, at the direction of the controller, for routing to the instrument(s) under test. All controls and responses of the calibrator can be accessed with the system controller except the POWER switch.

CAUTION

There are protective diodes between the signal (logic) ground and equipment (chassis) ground. Damage to the equipment could result if the potential between these points exceeds 0.6V dc.

605-3. SPECIFICATIONS

605-4. Specifications for the IEEE 488-1975 Standard Interface, Option -05, conform to those established in the IEEE Standard Digital Interface for Programmable Instrumentation as published by the Institute of Electrical and Electronics Engineers; 345 E. 47th St.; N.Y., NY 10017. For an explanation of the IEEE 488-1975 Standard refer to the standard document.

605-5. INSTALLATION

605-6. The option may be installed at any time by inserting the option's pcb assembly into the rearmost connector in the digital compartment and removing the plate from the rear panel interface access port. All interface options go into this slot; however, only one can be installed at a time.

605-7. OPERATING FEATURES

605-8. Attached to the assembly and accessible through a port on the rear panel (Figure 605-1) are a standard specified connector, five address switches, and a Talk Only Mode switch. The connector is standard for the IEEE Bus and is specified by the standard document. The address of the instrument is set using the five address switches. The characters used to address the instrument in the Talk and Listen Modes are given in Table 605-1. The five low order bits of the message determine the address, the next two higher bits differentiate between the Talk and Listen Modes. Normal operation allows the calibrator to both talk and listen to the bus. The Listen Mode can be disabled with the Talk Only switch, if desired.

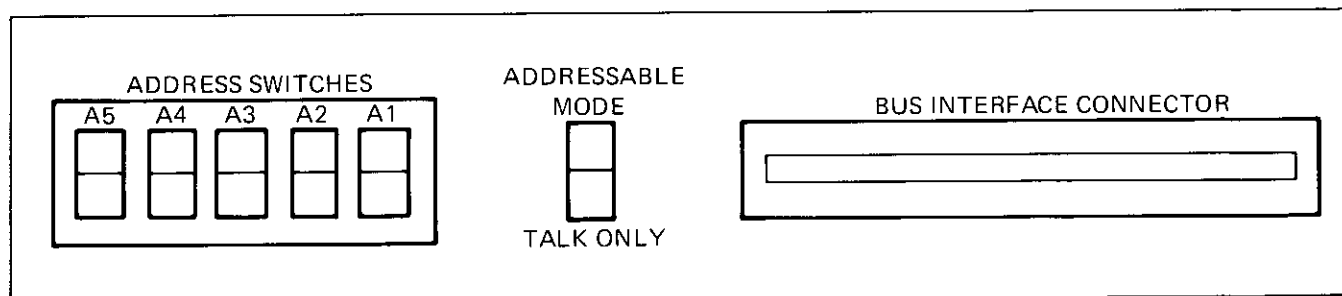

Figure 605-1. IEEE Access Port

Table 605-1. Allowable Listen and Talk Addresses

DECIMAL	5 4 3 2 1 BINARY	ASCII CHARACTER	
		LISTEN	TALK
0	0 0 0 0 0	SP	@
1	0 0 0 0 1	!	A
2	0 0 0 1 0	"	B
3	0 0 0 1 1	#	C
4	0 0 1 0 0	\$	D
5	0 0 1 0 1	%	E
6	0 0 1 1 0	&	F
7	0 0 1 1 1	'	G
8	0 1 0 0 0	(H
9	0 1 0 0 1)	I
10	0 1 0 1 0	*	J
11	0 1 0 1 1	+	K
12	0 1 1 0 0	,	L
13	0 1 1 0 1	-	M
14	0 1 1 1 0	.	N
15	0 1 1 1 1	/	O
16	1 0 0 0 0	0	P
17	1 0 0 0 1	1	Q
18	1 0 0 1 0	2	R
19	1 0 0 1 1	3	S
20	1 0 1 0 0	4	T
21	1 0 1 0 1	5	U
22	1 0 1 1 0	6	V
23	1 0 1 1 1	7	W
24	1 1 0 0 0	8	X
25	1 1 0 0 1	9	Y
26	1 1 0 1 0	:	Z
27	1 1 0 1 1	;	[
28	1 1 1 0 0	<	\
29	1 1 1 0 1	=]
30	1 1 1 1 0	>	^

605-9. OPERATING NOTES

605-10. Instrument Programming

605-11. The programming instructions required to operate the instrument are found in Section 2 of this manual.

605-2

605-12. Interface Control

605-13. Information is input to the interface from the controller on the System Bus, which contains eight data lines, three handshake lines, and five bus management lines. Control of the handshake and management lines is from the controller and will vary with the controller used. Refer to the instructions with the system controller for the information on how to obtain the correct level on these lines. The lines, and a brief explanation of their function, are given in Table 605-2. Refer to the IEEE 488-1975 Standard Manual for a further explanation of their function.

Table 605-2. Interface Control Lines

MNEMONIC	TITLE	EXPLANATION
EOI	End or Identify	Indicates end of multiple byte message.
DAV	Data Available	True with data on the bus.
NFRD	Not Ready For Data	True with all instruments on bus ready for data.
NDAC	Not Data Accepted	True with data accepted and can be removed.
IFC	Interface Clear	True places all interfaces in known quiescent state.
SRQ	Service Request	Draws attention of the controller to issuing device.
ATN	Attention	Differentiate between interface (True) and device dependent message (False).
REN	Remote Enable	Selects Remote (True) or Local (False).

605-14. Interface Messages

605-15. Multiple line messages are input to the interface from the controller using the data lines. The ones used within the instrument are listed with their codes in Table 605-3. Further information on the messages can be obtained from the IEEE 488-1975 Standard Manual.

605-16. Status Request Responses

605-17. A service request (SRQ) can be generated within the interface by either an error or ready condition, provided it was enabled by the applicable Interface

Table 605-3. Interface Messages

MNEMONIC	MESSAGE	CODING			ALL DEVICES RESPOND (Universal)	ADDRESSED DEVICES ONLY RESPOND	DEVICE IN LOCAL RESPONDS AND GOES TO REMOTE	NOTE
		BINARY	OCTAL	HEX				
MLA	My Listen Address	X F T A5 A4 A3 A2 A1				X	X	1
MTA	My Talk Address	X T F A5 A4 A3 A2 A1				X	X	1
UNL	Unlisten	X F T T T T T T	077	3F	X			
UNT	Untalk	X T F T T T T T	137	5F	X		X	
OTA	Other Talk Address	X X X X X X X X					X	2
SPE	Serial Poll Enable	X F F T T F F F	030	18	X		X	
SPD	Serial Poll	X F F T T F F T	031	19	X		X	
LLO	Local Lockout	X F F T F F F T	021	11	X		X	
GTL	Go To Local	X F F F F F F T	001	01		X		
DCL	Device Clear	X F F T F T F F	024	14	X			
SDO	Selected Clear	X F F F F T F F	004	04		X		

1. Setting of Address Switch
2. Any Address other than MTA

Interrupt Enable Code. When the instrument is addressed during a serial poll operation by the IEEE-488 Controller, and an interrupt was generated, the response byte will be a zero for ready or the numeric of the applicable Error Code. If the SRQ was not generated by the calibrator, the response is a null character (binary 00000000) to the controller.

605-18. THEORY OF OPERATION

605-19. General

605-20. The IEEE-488 interface assembly transfers data between the System Bus and the Internal Digital Bus. Signals on the system bus are fully defined in the IEEE-488 Standard with a brief description given in the paragraph on interface control.

605-21. The assembly consists of two PCBs that are fastened together electrically with a 56-pin post and connector set, and mechanically with screws and standoffs. The mainboard (MB) is numbered MIS-1172 and the secondary or piggyback board (PB) MIS-1072.

Refer to the schematics in Section 8 during the following discussion for the drawings of these two PCBs. Reference designators will be followed by the abbreviation for the applicable board, i.e., MB or PB, during the discussion.

605-22. Data Lines

605-23. Data is applied to the interface from the System Bus through the receiver/drivers U21 (MB) and U24 (MB) on lines DI01 through DI08 and is inverted and placed on the Digital Bus ID0 through ID7 from the Data Registers, U30 (MB) and U29 (MB). The data is latched in U26 (MB) and U29 (MB) to hold it after removal from the System Bus by the system controller, and at the same time the five low order bits are applied to the control register U11 (PB), U14 (PB) and U16 (PB). In addition, the data is decoded by S1, U3, U5, U6, U8, U12, and U19 (all on the mainboard) to obtain, if present, one of the signals in Table 605-3. In addition to the proper code, ATN must be low on the System Bus (J3-11) for any of the signals in Table 605-3 to be present. The signal GET (Group Execute Trigger) decoded at U8-11 (MB) is not used in the 5100 Series B.

605-24. Address Lines

605-25. The instrument address lines (IC0-IC6) are input on the Digital Bus and decoded to perform a series of internal functions, all of which generate an ACK at U6-1 (PB) for return to the instrument controller. IC1, 4, 5, high, are decoded at U12-6 (PB) to enable the response register, U26 (MB) and U29 (MB). IC3, 4, 6, high, are decoded at U12-10 (PB) to clock the control register; U11 (PB), U14 (PB) and U16 (PB). If ID0 is high at the same time, a Return to Local Signal is generated at U8-3 (PB). IC0, 3, 5, high, are decoded at U13-6 (PB) to provide a software reset at U8-8 (PB) to accompany the power-on reset at U8-9 (PB). IC0, 4, 6, high, are decoded at U13-10 (PB) to enable the data register U30 (MB) and U31 (MB).

605-26. Control Register

605-27. The control register consists of U11 (PB), U14 (PB) and U16 (PB). Four of the six latches are enabled from U12-10 (PB) described above. Of these INT (Interrupt) at U14-2 (PB) is controlled by ID3, SRQ at U14-13 (PB) by ID2, NFRD at U16-1 (PB) by ID2, and EOI at U11-13 (PB) by ID0. A NDAC is generated at U16 (PB) for the System Bus and to reset the NRFD previously generated. DAV is generated at U11-2 (PB), when clocked from U12-6 and addressed as a talker. INT is generated for an interrupt, with the proper input signals, except when the latch is held reset by the power-on reset routine. Refer to Table 605-2 for a brief explanation of the other signals.

605-28. Status Register

605-29. The status register in U28 (MB) and part of U31 (MB) stores signals decoded or input from the System Bus for placement on the Digital Bus. The register is clocked from U13-9 (PB) with IC0, IC4, and IC6, high. When the register has been enabled it reflects the status of the Talk Only Mode (high) on ID0, Remote Enable (REN) from the System Bus on ID1, GTI on ID2, MIA on ID3, INA for an interface message on ID4, device dependent message on ID5, serial-poll on ID6 and on ID7 when the system controller requests data.

605-30. Mode Register

605-31. Data that selects the operating mode is latched into the Mode Register by DAV. MIA will be at U11-1, if decoded, and MTA at U11-15. They are mutually exclusive and both points cannot be high simultaneously. U15-1 is clocked high when the instrument is in the Remote Mode and U15-15 when the serial-poll has been selected.

605-32. Reset

605-33. The instrument is automatically reset when power is reapplied after an interruption by the circuitry at U8-9 (PB). This prevents the instrument from coming up in an undesirable or unknown logic state. Software resets the instrument with a front panel RESET switch depression, system programming request or a momentary power interruption that is too short for the C3; R8 (PB) combination to discharge and cause a reset.

605-34. MAINTENANCE

605-35. Refer to Section 4 of the manual for instructions on the installation and cleaning of the assembly. The assembly is disassembled by removing the screws and standoffs that fasten the boards together, then pulling straight apart, to prevent damage to the electrical connectors.

605-36. PERFORMANCE TEST

605-37. Operation of the IEEE-488 interface may be verified by programming changes in range, output, and mode while observing the front panel for the proper indication. Operation of the calibrator should be verified before an attempt is made to program remotely.

605-38. CALIBRATION

605-39. The IEEE-488 interface assembly does not require any calibration.

605-40. TROUBLESHOOTING

605-41. Troubleshooting for the -05 Option IEEE 488-1975 Remote Interface consists of the tabular flow chart in Table 605-4. When a step in the flow chart is completed, check for a decision transfer. If no decision is required, perform the next step of the table in sequence.

605-42. LIST OF REPLACEABLE PARTS

605-43. Tables 605-5 and 605-6 are a list of replaceable parts for the IEEE-488 interface option. Refer to Section 5 for an explanation of the columnar entries.

Table 605-4. IEEE Remote Interface Troubleshooting

STEP NO.	ACTION	Go to the step number given for correct response	
		YES	NO
	<i>NOTE</i> <i>Due to the speed and complexity of the data on the bus system it is recommended that when a problem is isolated to the interface, the pcb be sent to the nearest Fluke Service Center for repair. The following table will be some assistance troubleshooting simpler problems; however, many problems will require the use of a Fluke Trendar, or similar logic board tester. The instrument must be connected through a bus network to a system controller, e.g., the Tektronix 4051 or HP 9825, to operate.</i>		
1	This test is based on the assumption that the instrument was checked and found operational in all local aspects prior to installing the IEEE Remote Interface in the instrument.		
2	Install the IEEE Interface Assembly in the instrument and apply power from the front panel switch.		
3	Does the Output Display read 0.0000 mV dc?	5	4
4	If the display is blank check the ACK circuit on the Piggyback (PB) PCB. If the display is incorrect (garbled or wrong) check the input latches and output buffers on the Main (MB) PCB. Repair as required then resume at step 2.		
5	Address the instrument on the IEEE Bus with the applicable address.		
6	Does the instrument go into remote?	8	7
7	On the Main Board check the address lines through the Receiver/Driver, the address switches, the MLA circuitry, and the REN and DAV signals. On the Piggyback Board check the INT circuit. Repair as required then resume at step 5.		
8	Program an instruction from the remote controller.		
9	Is the output display as programmed?	11	10
10	Check the output latches and buffers, the UNL circuitry and the Receiver/Driver on the Main Board. Repair as required then resume at step 8.		
11	Does the instrument respond to a "SRQ" from an Interrupt Ready or Error?	13	12
12	Check the SRQ line in and the Receiver/Driver on the Main Board and the status latches on the Piggyback Board. Repair as required then resume at step 11.		
13	Does the interface clear from the system controller?	15	14
14	Check the IFC input and the IFC circuit. Repair as required then resume at step 13.		
15	Can the Front Panel be locked out from the system controller?	17	16
16	Check the LLO line and the decoder circuit. Repair as required then resume at step 15.		
17	Troubleshooting of the IEEE Interface, as applicable at this level, is complete.		

Table 605-5. IEEE-488 Interface Main PCB Assembly

REF DES	DESCRIPTION	FLUKE STOCK NO.	MFG SPLY CODE	MFG PART NO. OR TYPE	TOT QTY	REC QTY	NOTE
A23	⊗ IEEE-488 INTERFACE MAIN PCB ASSEMBLY FIGURE 605-2 (MIS-4172)	ORDER	BY	OPTION -05			
A23A1	IEEE-488 INTERFACE PIGGYBACK ASSEMBLY FIGURE 605-3 (MIS-4072)	PART	OF	OPTION -05	1		
C1	CAP, MICA, 270 +/-5%, 500V	148452	72136	DM15F271J	2		
C2	CAP, MICA, 270+/-5%, 500V	148452	72136	DM15F271J	REF		
C3	CAP, TA, 10 UF +/-20%, 15V	193623	56289	196D106X0015KA1	1		
C4	CAP, CER, 0.22 UF +/-20%, 50V	309849	71590	CW30C224K	5		
C5	CAP, CER, 0.22 UF +/-20%, 50V	309849	71590	CW30C224K	REF		
C6	CAP, CER, 0.22 UF +/-20%, 50V	309849	71590	CW30C224K	REF		
C7	CAP, CER, 0.22 UF +/-20%, 50V	309849	71590	CW30C224K	REF		
C8	CAP, CER, 0.22 UF +/-20%, 50V	309849	71590	CW30C224K	REF		
C9	CAP, MICA, 100 PF +/-500V	148494	72136	DM15F101J	1		
CR1	DIODE, SI, HI-SPEED SWITCH	203323	07910	IN4448	1	1	
H1	SCREW, PHP, 4-40 X 3/8 (NOT SHOWN)	256164	89536	256164	1		
H3	WASHER LOCK, SPLIT #8 (TO J3)	111070	89536	111070	2		
H4	SCREW, CONN, MTG (TO J3)	429472	89536	429472	2		
J2	POST, HEADER	447813	22526	65501-136	38		
J3	CONNECTOR, CABLE	441337	02660	57-20240-8	1		
MP2	BAG, ANTI-STATIC (NOT SHOWN)	453530	89536	453530	1		
MP3	SPRING, COIL (NOT SHOWN)	424465	83553	C0120-014-0380	1		
Q1	XSTR, SI, NPN	218396	04713	2N3904	1	1	
R1	RES, COMP, 18K +/-5%, 1/4W	148122	01121	CB1835	1		
R2	RES, COMP, 10K +/-5%, 1/4W	148106	01121	CB1035	1		
R3	RES, COMP, 1K +/-5%, 1/4W	148023	01121	CB1025	1		
R4	RES, COMP, 4.7K +/-5%, 1/4W	148072	01121	CB4725	1		N
R5	RES, COMP, 15K +/-5%, 1/4W	148114	01121	CB1535	1		
S1	SWITCH, MODULE, DUAL IN LINE, SPDT	417766	00779	435470-4	1		
S2	SWITCH, SLIDE, SPDT	417287	95146	MSS-104D-1	1		
U1	⊗ IC, C-MOS, QUAD, 2-INPUT, NAND GATES	355198	02735	CD4011AE	1	1	
U2	⊗ IC, C-MOS, DUAL, 4-INPUT, NOR GATES	363820	02735	CD4002AE	1	1	
U3	⊗ IC, C-MOS, 8-INPUT NOR GATE	408781	02735	CD4073BE	3	1	
U4	⊗ IC, C-MOS, QUAD, 2-INPUT AND GATE	408401	02735	CD4081BE	2	1	
U5	⊗ IC, C-MOS, QUAD, 2-INPUT, NOR GATE	355172	02735	CD4001AE	3	1	
U6	⊗ IC, C-MOS, 8-INPUT NOR GATE	408781	02735	CD4073BE	REF		
U7	⊗ IC, C-MOS, TRIPLE 3-INPUT, NOR GATES	355180	02735	CD4025AE	1	1	
U8	⊗ IC, C-MOS, QUAD, 2-IN NOR GATE	355172	02735	CD4001AE	REF		
U9	⊗ IC, C-MOS, BIN TO 1 OF 4 DECODER/MULTI	408369	02735	CD4556BE	1	1	
U10	⊗ IC, C-MOS, QUAD, 2-INPUT OR GATE	408393	02735	CD4071BE	1	1	
U11	⊗ IC, C-MOS, DUAL, J-K MSTR SLAVE F/F	355230	02735	CD40271E	2	1	
U12	⊗ IC, C-MOS, TRIPLE 3-INPUT NAND GATES	375147	02735	CD4023AE	1	1	
U13	⊗ IC, C-MOS, HEX INVERTER	404681	02735	CD4069AE	2	1	
U14	⊗ IC, C-MOS, QUAD, 2-IN NOR GATE	355172	02735	CD4001AE	REF		
U15	⊗ IC, C-MOS, DUAL J-K MSTR SLAVE F/F	355230	02735	CD40271E	REF		
U16	⊗ IC, C-MOS, QUAD, 2-IN NAND SCHMITT TRIG	404632	02735	CD4093BE	1	1	
U17	⊗ IC, C-MOS, QUAD 2-INPUT AND GATE	408401	02735	CD4081BE	REF		
U18	⊗ IC, C-MOS, HEX INVERTER	404681	02735	CD4069AE	REF		
U19	⊗ IC, C-MOS, 8-INPUT NOR GATE	408781	02735	CD4073BE	REF		

Table 605-5. IEEE-488 Interface Main PCB Assembly (cont)

REF DES	DESCRIPTION	FLUKE STOCK NO.	MFG SPLY CODE	MFG PART NO. OR TYPE	TOT QTY	REC QTY	N O T E
U20	IC, QUAD, INTERFACE BUS TRANCEIVER	428649	04713	MC3446P	4		1
U21	IC, QUAD, INTERFACE BUS TRANCEIVER	428649	04713	MC3446P	REF		
U22	⊗ IC, C-MOS, HEX BUFFER/INVERTER	381848	02735	CD40409AE	2		1
U24	IC, QUAD, INTERFACE BUS TRANCEIVER	428649	04713	MC3446P	REF		
U25	⊗ IC, C-MOS, HEX BUFFER/INVERTER	381848	02735	CD40409AE	REF		
U26	⊗ IC, C-MOS, QUAD, CLOCKED D LATCH	355149	02735	CD4042AE	2		1
U27	IC, QUAD, INTERFACE BUS TRANCEIVER	428649	04713	MC3446P	REF		
U28	⊗ IC, C-MOS, TRI-ST, HEX NON-INVERT/BUFFER	407759	12040	MM80C97N	3		1
U29	⊗ IC, C-MOS, QUAD, CLOCKED D LATCH	355149	02735	CD4042AE	REF		
U30	⊗ IC, C-MOS, TRI-ST, HEX NON-INVERT/BUFFER	407759	12040	MM80C97N	REF		
U31	⊗ IC, C-MOS, TRI-ST, HEX NON-INVERT/BUFFER	407759	12040	MM80C97N	REF		
U32	IC, TTL, QUAD 2-IN, POS NAND GATES	393033	01295	SN74LS00N	1		1
U33	RES, NETWORK 4.7K+/-2%, 1/8W	412916	89536	412916	2		1
U34	RES, NETWORK 4.7K+/-2%, 1/8W	412916	89536	412916	REF		

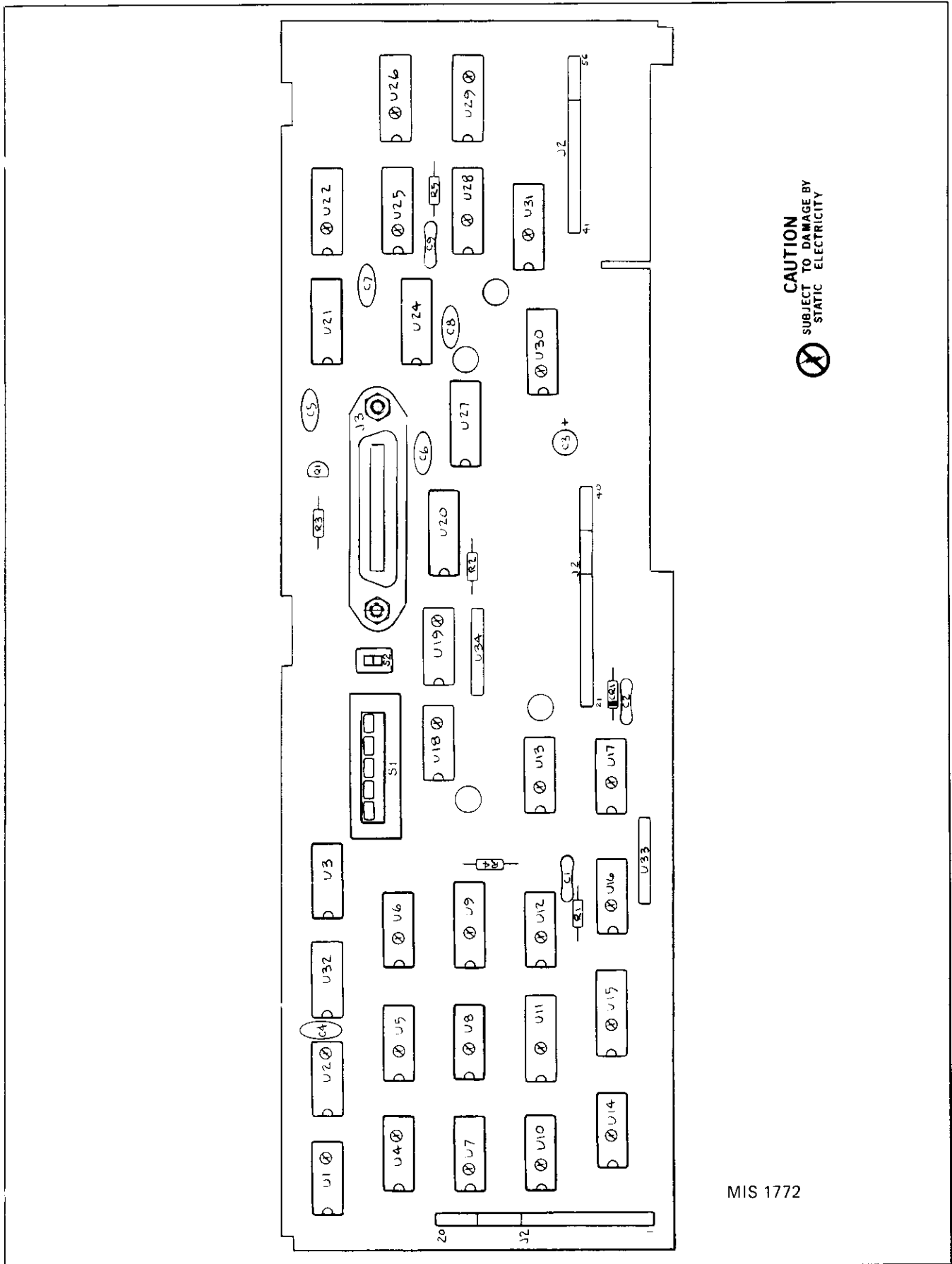

CAUTION
 SUBJECT TO DAMAGE BY
 STATIC ELECTRICITY

MIS 1772

Figure 605-2. IEEE-488 Interface PCB Assembly

Table 605-6. IEEE-488 Piggyback PCB Assembly

REF DES	DESCRIPTION	FLUKE STOCK NO.	MFG SPLY CODE	MFG PART NO. OR TYPE	TOT QTY	REC QTY	NOTE
A23A1	⊗ IEEE-488 PIGGYBACK PCB ASSEMBLY FIGURE 605-3 (MIS-4072)	ORDER PART	NEXT OF	HIGHER ASSEMBLY A23 OPTION -05	REF		
C1	CAP, MICA, 270 +/-5%, 500V	148452	72136	DM15F271J	2		
C2	CAP, MICA, 100 PF +/-5%, 500V	148494	72136	DM15F101J	1		
C3	CAP, TA, 1 UF +/-20%, 35V	161919	56289	196D105X0035JA1	1		
C4	CAP, MICA, 270 +/-5%, 500V	148452	72136	DM15F271J	REF		
CR1	DIODE, SI, HI-SPEED SWITCH	203323	07910	IN4448	1	1	
H1	WASHER, LOCK, 1/4 (W/P4)	110817	89536	110817	1		
H2	WASHER, FLAT (W/P4)	200980	86298	5710-65-16	1		
P2-1	SOCKET, SINGLE IN-LINE, 12-PIN	417733	30035	SS-109-1-12	3		
P2-2	SOCKET, SINGLE IN-LINE, 4-PINS	417311	30035	SS-109-1-04	5		
P4	CONNECTOR, JACK, BLK	441741	83330	205-103	1		
Q1	XSTR, SI, NPN	218396	04713	2N3904	1	1	
Q2	XSTR, SI, PNP	226290	04713	MPS3640	1	1	
R1	RES, COMP, 10K +/-5%, 1/4W	148106	01121	CB1035	3		
R2	RES, COMP, 47K +/-5%, 1/4W	148163	01121	CB4735	2		
R3	RES, COMP, 150 +/-5%, 1/4W	147934	01121	CB1515	2		
R4	RES, COMP, 150 +/-5%, 1/4W	147934	01121	CB1515	REF		
R5	RES, COMP, 10K +/-5%, 1/4W	148106	01121	CB1035	REF		
R6	RES, COMP, 47K +/-5%, 1/4W	148163	01121	CB4735	REF		
R7	RES, COMP, 10K +/-5%, 1/4W	148106	01121	CB1035	REF		
R8	RES, COMP, 15K +/-5%, 1/4W	148114	01121	CB1535	1		
U1	⊗ IC, C-MOS, DUAL "D"-TYPE, F/F	340117	04713	MC14013CP	4		
U2	⊗ IC, C-MOS, QUAD, 2-INPUT NOR GATES	355172	02735	CD4001AE	2		
U3	⊗ IC, C-MOS, QUAD, 2-IN, NAND SCHMITT TRIG	404632	02735	CD4093BE	1	1	
U4	⊗ IC, C-MOS, QUAD, 2-INPUT NOR GATES	355172	02735	CD4001AE	REF		
U5	⊗ IC, C-MOS, HEX INVERTER	404681	02735	CD4069AE	2	1	
U6	⊗ IC, C-MOS, DUAL 4-INPUT NOR GATES	363820	02735	CD4002AE	1	1	
U7	⊗ IC, C-MOS, HEX INVERTER	404681	02735	CD4069AE	REF		
U8	⊗ IC, C-MOS, QUAD 2-INPUT NAND GATES	355198	02735	CD4011AE	2	1	
U9	⊗ IC, C-MOS, QUAD 2-INPUT NAND GATES	355198	02735	CD4011AE	REF		
U10	⊗ IC, C-MOS, HEX BUFFER/INVERTER	381848	02735	CD4049AE	1	1	
U11	⊗ IC, C-MOS, DUAL "D"-TYPE, F/F	340117	04713	MC14013CP	REF		
U12	⊗ IC, C-MOS, TRIPLE 3-IN, AND GATE	408807	02735	CD4073BE	1	1	
U13	⊗ IC, C-MOS, TRIPLE, 3-IN, NAND GATES	375147	02735	CD4023AE	1	1	
U14	⊗ IC, C-MOS, DUAL "D"-TYPE, F/F	340117	04713	MC14013CP	REF		
U16	⊗ IC, C-MOS, DUAL "D"-TYPE, F/F	340117	04713	MC14013CP	REF		
U17	⊗ IC, C-MOS, TRIPLE 3-INPUT, NOR GATE	355180	02735	CD4025AE	1	1	

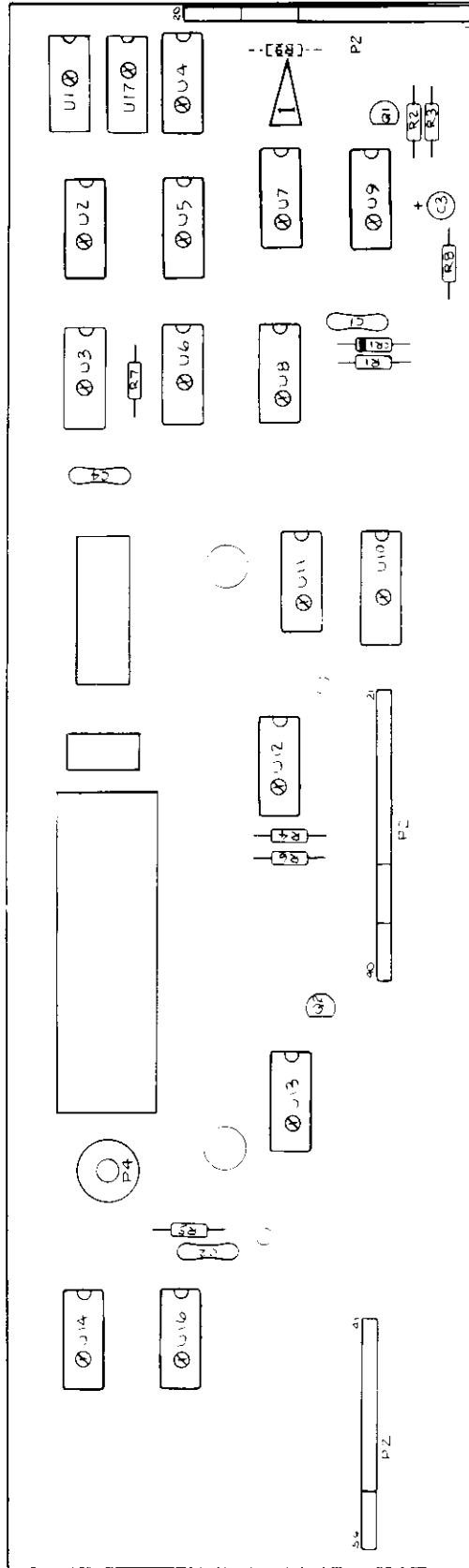

NOTE:  R9 may not be installed, selected in test.

MIS-1674

 **CAUTION**
SUBJECT TO DAMAGE BY
STATIC ELECTRICITY

Figure 605-3. IEEE-488 Piggyback PCB Assembly

-06 Option Bit Serial Asynchronous Interface (RS-232-C)

606-1. INTRODUCTION

606-2. The Bit Serial Asynchronous Interface takes the eight-bit parallel data in the calibrator, converts it to a bit serial format and outputs it to a system controller on a RS-232-C Bus. Data from the system controller is altered in the same way, allowing for full control of the instrument by a remote source. All controls and responses of the calibrator can be accessed with the system controller through the bit serial interface except the power switch.

CAUTION

There are protective diodes between the signal (logic) ground and equipment (chassis) ground. Damage to the equipment could result if the potential between these points exceeds 0.6V dc.

606-3. SPECIFICATIONS

606-4. The bit serial interface meets or exceeds the data transmission and receiving requirements of EIA Standard RS-232-C, RS-232-B, MIL-STD-188B, CCITT V24, and the 20 mA current loop. Baud rates of 50, 75, 110, 134.5, 150, 200, 300, 600, 1200, 1800, 2400, 4800, and 9600 are switch selectable.

606-5. INSTALLATION

606-6. The option may be installed at any time by inserting the option's single PCB into the rearmost connector in the digital compartment. All interface options go into the same slot; however, only one can be installed at a time.

606-7. OPERATING FEATURES

606-8. Attached to the PCB and accessible through a port on the rear panel (Figure 606-1) are a standard specified connector and a switch module with eight microswitches. The connector is standard for the RS-232-C interface and is specified by the standard document. The eight switches control the operating modes of the interface and the baud rate. The modes selected by the switches are shown in Tables 606-1 and Table 606-2. The selection of Odd or Even parity with switch 8 is applicable only if the parity feature has been selected using the jumpers described below.

606-9. The interface is shipped configured for an eight-bit character without parity. Selection of parity and five-, six-, or seven-bit characters can be accomplished by installing jumpers into the PCB as shown in Table 606-3

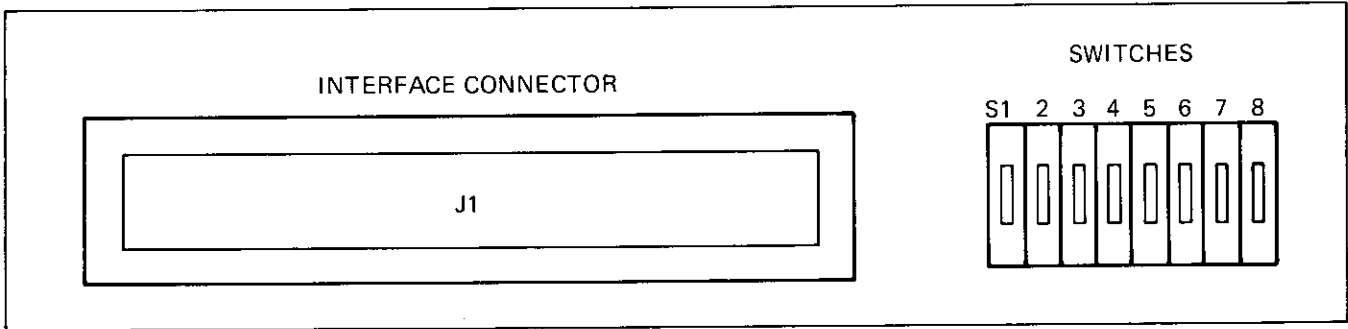

Figure 606-1. Bit Serial Access Port

Table 606-1. Switch Selection

SW#	SELECTION	SW ON	SW OFF
S1	Current Loop/ RS232	Current	RS232C
S2	RS232B/ RS232C	RS232B	RS232C
S3	Stop Bits	1 Bit	2 Bits
S4	Baud Rate	*	*
S5	Baud Rate	*	*
S6	Baud Rate	*	*
S7	Baud Rate	*	*
S8	Parity	Odd	Even

*Defined in Table 606-2

Table 606-2. Baud Rate

COUNT	S4	S5	S6	S7	BAUD RATE
0	OFF	OFF	OFF	OFF	110
1	OFF	OFF	OFF	ON	150
2	OFF	OFF	ON	OFF	300
3	OFF	OFF	ON	ON	2400
4	OFF	ON	OFF	OFF	1200
5	OFF	ON	OFF	ON	1800
6	OFF	ON	ON	OFF	4800
7	OFF	ON	ON	ON	9600
8	ON	OFF	OFF	OFF	2400
9	ON	OFF	OFF	ON	600
10	ON	OFF	ON	OFF	200
11	ON	OFF	ON	ON	134.5
12	ON	ON	OFF	OFF	75
13	ON	ON	OFF	ON	50

Table 606-3. Character Length and Parity

	JUMPER #1 INSTALLED	JUMPER #2 INSTALLED	JUMPER #3 INSTALLED
Bit 5	Yes	Yes	N/A
Bit 6	No	Yes	N/A
Bit 7	Yes	No	N/A
Bit 8	No	No	N/A
Parity	N/A	N/A	Yes
No Parity	N/A	N/A	No

606-10. OPERATING NOTES

606-11. Programming instructions required to operate the instrument are found in Section 2 of this manual.

606-12. THEORY OF OPERATION

606-13. General

606-14. The bit serial interface alters to the proper format and transmits data between the eight-bit (byte) parallel format used on the Instrument Bus and the bit serial format of the System Bus. As shown on the schematic in Section 8, data inputs from either the System Bus or the Instrument Bus are latched into a Universal Asynchronous Receiver Transmitter (UART) U9, which is driven by a programmable clock (U3) set at the selected baud rate. Data on the Instrument Bus (ID0-ID7) is latched into the UART on DB1 through DB8 and output from the UART to the Instrument Bus on RD1 through RD8. Four separate functions are decoded from the control lines and the receipt of any one generates a common acknowledge signal (ACK). An interrupt function can be generated to notify the instrument controller the received data is available, allowing polled or interrupt control of the interface.

606-15. Functions

606-16. An address of IC0, IC4, and IC6 high with the remaining lines low, generates the STATIN function. This generates ACK and enables the tri-state transmitters on the ID0-ID3 lines so that DA (received data available at RD1-RD8), OR (overrun, i.e., a new character received prior to final transmission of the previous character), TBMT (Transmitter Buffer Empty and ready for the next character), and/or FE (Framing Error; i.e., no stop-bit with received character) can be placed on the data lines.

606-17. The DATIN function (IC1, IC4, IC6, only high) strobes the RDE and RDA inputs to the UART. The UART is enabled to place data on the Instrument Bus by RDE and to receive another serial character from the System Bus by RDA.

606-18. With IC2, IC4, and IC5, only, high COUT is decoded to reset the UART and clock U5-3. If IC7 is high with COUT, the interrupt capability is disabled by enabling the reset at U5-10. This prevents an interrupt signal to the instrument controller until removed. If ID7 is low, the interrupt circuitry is enabled.

606-19. DATOUT is decoded, from IC3, IC4, and IC6, only, high, to strobe the DS input to the UART. The rising edge of DS initiates serial transmission of the character from SO onto the System Bus. It is available at both J1-2 for RS-232-C and J1-11 for the 20 mA current loop, for the user's selection.

606-20. Interrupt

606-21. When DA (received data available) goes high, an interrupt is generated unless it has been disabled by the COUT function, for a low at INT. The instrument controller responds with an INA, generating an ACK and enabling U8-15 to pass the output of the interrupt flip-flop to the instrument controller for interrupt vectoring. The removal of INA by the instrument controller causes the interrupt flip-flop to reset itself and prepare the circuit for the next interrupt.

606-22. MAINTENANCE

606-23. Refer to Section 4 of the manual for instructions on the cleaning and installation of the assembly.

606-24. PERFORMANCE TEST

606-25. Operation of the bit serial interface may be verified by programming changes in range, output and mode while observing the Front Panel for the proper

indications. If the echoing capability is selected, the instruction sent can be monitored on the output device. Operation of the calibrator should be verified before an attempt is made to program remotely.

606-26. CALIBRATION

606-27. The Bit Serial Asynchronous Interface does not require any calibration.

606-28. TROUBLESHOOTING

606-29. Troubleshooting for the -06 Bit Serial Asynchronous Interface Option consists of the tabular flow chart in Table 606-4. When a step in the flow chart is complete, check for a decision transfer. If no decision is required, perform the next step of the table in sequence.

606-30. LIST OF REPLACEABLE PARTS

606-31. Table 606-5 is a list of replaceable parts for the bit serial interface option. Refer to Section 5 for an explanation of the columnar entries.

Table 606-4. Bit Serial Remote Interface Troubleshooting

STEP NO.	ACTION	Go to the step number given for correct response	
		YES	NO
	<i>NOTE</i> <i>The instrument must be connected through a bus network to a system controller, e.g., the Tektronix 4051 or HP 9825, to operate.</i>		
1	This test is based on the assumption that the instrument was checked in local and found operational in all aspects prior to installing the Bit Serial Asynchronous (RS-232-C) Remote Interface in the Instrument.		
2	Install the Bit Serial Interface in the instrument and apply power from the Front Panel switch.		
3	Does the output display read 0.0000 mV dc?	7	4
4	Does the central display read "Err6"?	6	5
5	If the display is blank check for a high ACK line, check the address lines and the address decoders. If the display is incorrect (garbled or wrong) check the input data lines and gates. Repair as required then resume at step 2.		
6	Check the address decoder and ACK circuit. Repair as required then resume at step 2.		
7	Using the controller, instruct the program to go to remote (program the character "J").		
8	Does the instrument go to remote?	10	9
9	Check the input gates, the UART (U9), the BAUD rate (U3), the INT circuit, the INA circuit, and the status output circuit. Repair as required then resume at step 7.		
10	Program several instructions into the Calibrator from the remote controller.		
11	Did the instrument respond correctly to the programmed instruction?	13	12
12	Check the UART (U9), the output circuit (U4), and the data input gate (U7). Repair as required then resume at step 10.		
13	Troubleshooting of the Bit Serial Interface, as applicable at this level, is complete.		

Table 606-5. Bit Serial Interface Assembly

REF DES	DESCRIPTION	FLUKE STOCK NO.	MFG SPLY CODE	MFG PART NO. OR TYPE	TOT QTY	REC QTY	NO TE
A22	⊗ BIT SERIAL INTERFACE ASSEMBLY FIGURE 606-2 (MIS-1170T)	ORDER	BY	OPTION -06			
C1	CAP, TANT, 5.6 UF +/-20%, 25V	368969	56289	1960565X0025KA1	3		
C2	CAP, TANT, 5.6 UF +/-20%, 25V	368969	56289	1960565X0025KA1	REF		
C3	CAP, TANT, 5.6 UF +/-20%, 25V	368969	56289	1960565X0025KA1	REF		
C4	CAP, MICA, 56 PF +/-5%, 500V	148528	72136	DM15F560-J	2		
C5	CAP, MICA, 56 PF +/-5%, 500V	148528	72136	DM15F560-J	REF		
C6	CAP, CER, 0.22 UF +/-20%, 50V	309849	71390	CW30C224K	4		
C7	CAP, CER, 0.22 UF +/-20%, 50V	309849	71390	CW30C224K	REF		
C8	CAP, CER, 0.22 UF +/-20%, 50V	309849	71390	CW30C224K	REF		
C9	CAP, CER, 0.22 UF +/-20%, 50V	309849	71390	CW30C224K	REF		
CR1	DIODE, HI-SPEED SWITCHING	203323	07910	IN4448	1	1	
H1	SCREW, 4-40 X 1/4	129890	73734	19022	2		
H3	SCREW, FHP, UNDERCUT 6-32 X 1/4 (IN BAG)	320093	89536	320093	2		
J1	CONNECTOR, D, SUB-MINI	413898	71785	DB25PV	1		
MP1	CLIP, SPRING, ASSY	330134	89536	330134	1		
MP3	SHIELD, FRONT I/O ASSY (IN BAG)	383372	89536	383372	1		
MP4	BAG, ANTI-STATIC	453548	89536	453548	1		
Q1	XSTR, NPN, SI	218396	04713	2N3904	1	1	
Q2	XSTR, PNP, SI	226290	04713	MPS3640	1	1	
Q3	XSTR, PNP, SI	195974	04713	2N3906	1	1	
R1	RES, COMP, 150 +/-5%, 1/4W	147934	01121	CB1515	2		
R2	RES, COMP, 47K +/-5%, 1/4W	148163	01121	CB4735	1		
R3	RES, COMP, 10K +/-5%, 1/4W	148106	01121	CB1035	1		
R4	RES, COMP, 150 +/-5%, 1/4W	147934	01121	CB1515	REF		
R5	RES, COMP, 10M +/-5%, 1/4W	194944	01121	CB1065	1		
R6	RES, COMP, 33K +/-5%, 1/4W	148155	01121	CB3335	1		
R7	RES, COMP, 1K +/-5%, 1/4W	148023	01121	CB1025	2		
R8	RES, COMP, 2.2K +/-5%, 1/4W	148049	01121	CB2225	1		
R9	RES, COMP, 47 +/-5%, 1/4W	147892	01121	CB4705	1		
R10	RES, COMP, 750 +/-5%, 1/4W	218024	01121	CB7515	1		
R11	RES, COMP, 4.7K +/-5%, 1/4W	148072	01121	CB4725	3		
R12	RES, COMP, 4.7K +/-5%, 1/4W	148072	01121	CB4725	REF		
R13	RES, COMP, 620 +/-5%, 1/4W	221903	01121	CB6215	1		
R14	RES, COMP, 1K +/-5%, 1/4W	148023	01121	CB1025	REF		
R15	RES, COMP, 4.7K +/-5%, 1/4W	148072	01121	CB4725	REF		
S1-S8	SWITCH, SPST	414490	00779	435166-5	1		
U1	IC, TTL, DUAL, EIA/MIL LINE RECEIVERS	354704	18324	8T16A	1	1	
U2	⊗ IC, C-MOS, HEX, INVERTER/BUFFER	381848	02735	CD4049AE	1	1	
U3	⊗ IC, C-MOS, PROGRAMMABLE, BIT RATE	418731	07263	F4702/34702	1	1	
U4	IC, TTL, MSI, DUAL, EIA/MTL LINE DRIVERS	354696	18324	N8T15A	1	1	
U5	⊗ IC, C-MOS, DUAL, "D"-TYPE, F/F	340117	02735	CD4013AE	1	1	
U6	⊗ IC, C-MOS, QUAD 2-INPUT NAND GATES	375147	02735	CD4023AE	2	1	
U7	⊗ IC, C-MOS, QUAD 2-INPUT NAND GATES	375147	02735	CD4023AE	REF		
U8	⊗ IC, C-MOS, TRI-STATE HEX, NON-INVRT BUFF	407759	12040	MM80C97N	1	1	
U9	IC, UNIV ASYNCHRONOUS, REC/TRANS	354753	05828	AY-5-1013	1	1	
U10	⊗ IC, C-MOS, TRIPLE, 3-INPUT AND GATE	408807	02735	CD4073B	1	1	
U11	⊗ IC, C-MOS, QUAD, 2-INPUT, NAND GATE	355198	02735	CD4011AE	1	1	
U12	⊗ IC, C-MOS, HEX, INVERTER, BUFFER	381830	02735	CD4050AE	2	1	
U13	⊗ IC, C-MOS, HEX, INVERTER, BUFFER	381830	02735	CD4050AE	REF		
V1	CRYSTAL, QUARTZ	435370	89536	435370	1		
XU9	SOCKET, IC	418988	91506	340-AG39D	1		

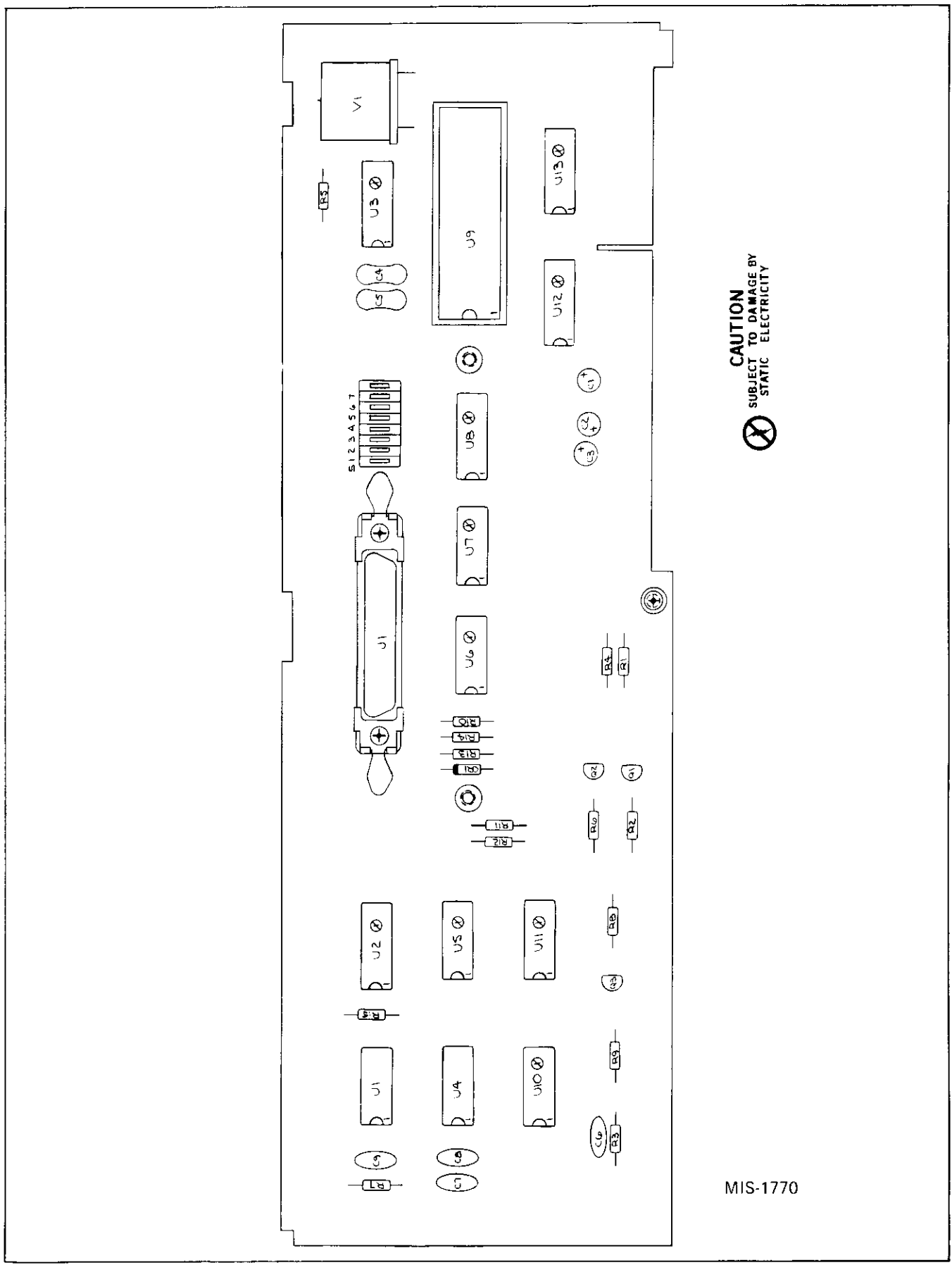

Figure 606-2. Bit Serial Interface Assembly

Section 7

General Information

7-1. This section of the manual contains generalized user information as well as supplemental information to the List of Replaceable Parts contained in Section 5.

List of Abbreviations and Symbols

A or amp	ampere	hf	high frequency	(+) or pos	positive
ac	alternating current	Hz	hertz	pot	potentiometer
af	audio frequency	IC	integrated circuit	p-p	peak-to-peak
a/d	analog-to-digital	if	intermediate frequency	ppm	parts per million
assy	assembly	in	inch(es)	PROM	programmable read-only memory
AWG	american wire gauge	intl	internal	psi	pound-force per square inch
B	bel	I/O	input/output	RAM	random-access memory
bcd	binary coded decimal	k	kilo (10^3)	rf	radio frequency
°C	Celsius	kHz	kilohertz	rms	root mean square
cap	capacitor	kΩ	kiloohm(s)	ROM	read-only memory
ccw	counterclockwise	kV	kilovolt(s)	s or sec	second (time)
cer	ceramic	lf	low frequency	scope	oscilloscope
cermet	ceramic to metal(seal)	LED	light-emitting diode	SH	shield
ckt	circuit	LSB	least significant bit	Si	silicon
cm	centimeter	LSD	least significant digit	serno	serial number
cmrr	common mode rejection ratio	M	mega (10^6)	sr	shift register
comp	composition	m	milli (10^{-3})	Ta	tantalum
cont	continue	mA	milliampere(s)	tb	terminal board
crt	cathode-ray tube	max	maximum	tc	temperature coefficient or temperature compensating
cw	clockwise	mf	metal film	tcxo	temperature compensated crystal oscillator
d/a	digital-to-analog	MHz	megahertz	tp	test point
dac	digital-to-analog converter	min	minimum	u or μ	micro (10^{-6})
dB	decibel	mm	millimeter	uhf	ultra high frequency
dc	direct current	ms	millisecond	us or μs	microsecond(s) (10^{-6})
dmm	digital multimeter	msb	most significant bit	uut	unit under test
dvm	digital voltmeter	MSD	most significant digit	V	volt
elect	electrolytic	MTBF	mean time between failures	v	voltage
ext	external	MTTR	mean time to repair	var	variable
F	farad	mV	millivolt(s)	vco	voltage controlled oscillator
°F	Fahrenheit	mv	multivibrator	vhf	very high frequency
FET	Field-effect transistor	MΩ	megohm(s)	vlf	very low frequency
ff	flip-flop	n	nano (10^{-9})	W	watt(s)
freq	frequency	na	not applicable	ww	wire wound
FSN	federal stock number	NC	normally closed	xfmr	transformer
g	gram	(-) or neg	negative	xstr	transistor
G	giga (10^9)	NO	normally open	xtal	crystal
gd	guard	ns	nanosecond	xtlo	crystal oscillator
Ge	germanium	opnl ampl	operational amplifier	Ω	ohm(s)
GHz	gigahertz	p	pico (10^{-12})	μ	micro (10^{-6})
gmV	guaranteed minimum value	para	paragraph		
gnd	ground	pcb	printed circuit board		
H	henry	pF	picofarad		
hd	heavy duty	pn	part number		

Federal Supply Codes for Manufacturers

D9816 Westemann Wilhelm Augusta-Anlage Mannheim-Nackarau Germany	02533 Leigh Instruments Ltd. Frequency Control Div. Don Mills, Ontario, Canada	04713 Motorola Inc. Semiconductor Group Phoenix, Arizona	06665 Precision Monolithics Sub of Bourns Inc. Santa Clara, California
00199 Marcon Electronics Corp Kearny, New Jersey	02606 Fenwal Labs Division of Travenal Labs Morton Grove, Illinois	05236 Jonathan Mfg. Co. Fullerton, California	06666 General Devices Co. Inc. Indianapolis, Indiana
00213 Nytronics Comp. Group Inc. Darrington, South Carolina	0266 Bunker Ramo-Eltra Corp. Amphenol NA Div. Broadview, Illinois	05245 Corcom Inc. Libertyville, Illinois	06739 Electron Corp. Littleton, Colorado
00327 Welwyn International Inc. Westlake, Ohio	02735 RCA-Solid State Div. Somerville, New Jersey	05276 ITT Pomona Electronics Div. Pomona, California	06743 Gould Inc. Foil Div. Eastlake, Ohio
00656 Aerovox Corp. New Bedford, Massachusetts	02799 Arco Electronics Inc. Chatsworth, California	05277 Westinghouse Elec. Corp. Semiconductor Div. Youngwood, Pennsylvania	06751 Components Inc. Sencor Div. Phoenix, Arizona
00686 Film Capacitors Inc. Passaic, New Jersey	03508 General Electric Co. Semiconductor Products & Batteries Auburn, New York	05397 Union Carbide Corp. Materials Systems Div. Cleveland, Ohio	06776 Robinson Nugent Inc. New Albany, Indiana
00779 AMP, Inc. Harrisburg, Pennsylvania	03797 Genisco Technology Corp. Eltronics Div. Rancho Dominguez, Calif.	05571 Sprague Electric Co. (Now 56289)	06915 Richeo Plastic Co. Chicago, Illinois
01121 Allen Bradley Co. Milwaukee, Wisconsin	03877 Gilbert Engineering Co. Inc Incon Sub of Transitron Electronic Corp. Glendale, Arizona	05574 Viking Connectors Inc Sub of Criton Corp. Chatsworth, Calif.	06961 Vernitron Corp. Piezo Electric Div. Bedford, Ohio
01281 TRW Electronics & Defense Sector Lawndale, California	03888 KDI Electronics Inc. Pyrofilm Div. Whippany, New Jersey	05820 EG & G Wakefield Engineering Wakefield, Massachusetts	06980 Varian Associates Inc. Eimac Div. San Carlos, California
01295 Texas Instruments Inc. Semiconductor Group Dallas, Texas	03911 Clairex Corp. Clairex Electronics Div. Mount Vernon, New York	05972 Locute Corp. Newington, Connecticut	07047 Ross Milton Co., The Southampton, Penna.
01537 Motorola Communications & Electronics Inc. Franklin Park, Illinois	03980 Muirhead Inc. Mountainside, New Jersey	06001 General Electric Co. Electric Capacitor Product Section Columbia, S. Carolina	07138 Westinghouse Electric Corp. Industrial & Government Tube Div. Horseheads, New York
01686 RCL Electronics/Shallcross Inc. Electro Components Div. Manchester, New Hampshire	04009 Cooper Industries, Inc. Arrow Hart Div. Hartford, Connecticut	06141 Fairchild Weston Systems Inc. Data Systems Div. Sarasota, Florida	07233 Benchmark Technology Inc. City of Industry, Calif.
01884 Sprague Electric Co. (Now 56289)	04217 Essex International Inc. Wire & Cable Div. Anaheim, California	06192 La Deau Mfg. Co. Glendale, California	07239 Biddle Instruments Blue Bell, Penna.
01961 Varian Associates Inc. Pulse Engineering Div. Convoy, Connecticut	04221 Midland-Ross Corp. Midtex Div. N. Mankato, Minnesota	06229 Electrovert Inc. Elmsford, New York	07256 Silicon Transistor Corp. Sub of BBF Inc. Chelmsford, Massachusetts
02111 Spectrol Electronics Corp. City of Industry, California	04222 AVX Corp. AVX Ceramics Div. Myrtle Beach, S. Carolina	06383 Panduit Corp. Tinley Park, Illinois	07261 Avnet Corp. Culver City, California
02114 Amperex Electronic Corp. Ferrox Cube Div. Saugerties, New York	04423 Telonic Berkley Inc. Laguna Beach, California	06473 Bunker Ramo Corp. Amphenol NA Div. SAMS Operation Chatsworth, California	07263 Fairchild Camera & Instrument Semiconductor Div. Mountain View, California
02131 General Instrument Corp. Government Systems Div. Westwood, Massachusetts		06555 Beede Electrical Instrument Penacook, New Hampshire	07344 Bircher Co. Inc., The Rochester, New York
02395 Sonar Radio Corp. Hollywood, Florida			

Federal Supply Codes for Manufacturers (cont)

07557 Campion Co. Inc. Philadelphia, Penna.	09423 Scientific Components Inc. Santa Barbara, California	11711 General Instrument Corp. Rectifier Div. Hicksville, New York	12954 Microsemi Corp. Components Group Scottsdale, Arizona
07597 Burndy Corp. Tape/Cable Div. Rochester, New York	09579 CTS of Canada, Ltd Streetsville, Ontario	11726 Qualidyne Corp. Santa Clara, California	12969 Unitrode Corp. Lexington, Massachusetts
07716 TRW Inc. (Can use 11502) IRC Fixed Resistors/ Burlington Burlington, Iowa	09922 Burndy Corp. Norwalk, Connecticut	12014 Chicago Rivet & Machine Co. Naperville, Illinois	13050 Potter Co. Wesson, Mississippi
07792 Lenma Engineering Corp. Northampton, Massachusetts	09969 Dale Electronics Inc. Yankton, South Dakota	12040 National Semiconductor Corp. Danbury, Connecticut	13103 Thermalloy Co., Inc. Dallas, Texas
07810 Bock Corp. Madison, Wisconsin	09975 Burroughs Corp. Electronics Components Detroit, Michigan	12060 Diodes Inc. Northridge, California	13327 Solitron Devices Inc. Tappan, New York
07933 Raytheon Co. Semiconductor Div. Mountain View, Calif.	10059 Barker Engineering Corp. Kenilworth, New Jersey	12136 PHC Industries Inc. Formerly Philadelphia Handle Co. Camden, New Jersey	13511 Bunker-Ramo Corp. Amphenol Cadre Div. Los Gatos, California
08235 Industro Transistor Corp. Long Island City, New York	10389 Illinois Tool Works Inc. Licon Div. Chicago, Illinois	12300 AMF Canada Ltd. Potter-Brumfield Guelph, Ontario, Canada	13606 Sprague Electric Co. (Use 56289)
08261 Spectra-Strip An Eltra Co. Garden Grove, Calif.	10582 CTS of Asheville Skyland, N. Carolina	12323 Practical Automation Inc. Shelton, Connecticut	13689 SPS Technologies Inc. Hatfield, Pennsylvania
08530 Reliance Mica Corp. Brooklyn, New York	11236 CTS Corp. Beme Div. Beme, Indiana	12327 Freeway Corp. Cleveland, Ohio	13919 Burr-Brown Research Corp. Tucson, Arizona
08718 ITT Cannon Electric Phoenix Div. Phoenix, Arizona	11237 CTS Corp of California Paso Robles Div. Paso Robles, California	12443 Budd Co.,The Plastics Products Div. Phoenixville, Pennsylvania	14099 Semtech Corp. Newbury Park, California
08806 General Electric Co. Miniature Lamp Products Cleveland, Ohio	11295 ECM Motor Co. Schaumburg, Illinois	12581 Hitachi Metals International Ltd. Hitachi Magna-Lock Div. Big Rapids, Missouri	14140 McGray-Edison Co. Commercial Development Div. Manchester, New Hampshire
08863 Nylomatic Fallsington, Penna.	11358 Columbia Broadcasting System CBS Electronic Div. Newburyport, Massachusetts	12615 US Terminals Inc. Cincinnati, Ohio	14193 Cal-R-Inc. Santa Monica, California
08988 Skottie Electronics Inc. Archbald, Pennsylvania	11403 Vacuum Can Co. Best Coffee Maker Div. Chicago, Illinois	12617 Hamlin Inc. Lake Mills, Wisconsin	14298 American Components Inc. an Insilco Co. RPC Div. Conshohocken, Pennsylvania
09021 Aircro Inc. Aircro Electronics Bradford, Penna.	11502 TRW Inc. TRW Resistive Products Div. Boone, North Carolina	12697 Ciarostat Mfg. Co. Inc. Dover, New Hampshire	14298 ACIC Inc. Sub of Insilco Corp. Research Triangle Park, NC
09023 Cornell-Dublier Electronics Fuquay-Varina, N. Carolina	11503 Keystone Columbia Inc. Freemont, Indiana	12749 James Electronic Inc. Chicago, Illinois	14329 Wells Electronics Inc. South Bend, Indiana
09214 General Electric Co. Semiconductor Products Dept. Auburn, New York	11532 Teledyne Relays Teledyne Industries Inc. Hawthorne, California	12856 MicroMetals Inc. Anaheim, California	14482 Watkins-Johnson Co. Palo Alto, California
09353 C and K Components Inc. Newton, Massachusetts		12881 Metex Corp. Edison, New Jersey	14552 Microsemi Corp. Santa Ana, California
		12895 Cleveland Electric Motor Co. Cleveland, Ohio	14655 Cornell-Dublier Electronics Div. of Federal Pacific Electric Co. Govt Cont Dept. Newark, New Jersey

Federal Supply Codes for Manufacturers (cont)

14704 Crydom Controls (Division of Int Rectifier) El Segundo, California	16733 Cablewave Systems Inc. North Haven, Connecticut	18927 GTE Products Corp. Precision Material Products Business Parts Div. Titusville, Pennsylvania	23936 William J. Purdy Co. Pamotor Div. Burlingame, California
14752 Electro Cube Inc. San Gabriel, California	16742 Paramount Plastics Fabricators Inc. Downey, California	19315 Bendix Corp., The Navigation & Control Group Teaboro, New Jersey	24347 Penn Engineering Co. S. El Monte, California
14936 General Instrument Corp. Discrete Semi Conductor Div. Hicksville, New York	16758 General Motors Corp. Delco Electronics Div. Kokomo, Indiana	19451 Perine Machinery & Supply Co.. Kent, Washington	24355 Analog Devices Inc. Norwood, Massachusetts
14949 Trompeter Electronics Chatsworth, California	17069 Circuit Structures Lab Burbank, California	19613 Minnesota Mining & Mfg. Co. Textool Products Dept. Electronic Product Div. Irving, Texas	24444 General Semiconductor Industries, Inc. Tempe, Arizona
15412 Amtron Midlothian, Illinois	17117 Electronic Molding Corp. Woonsocket, Rhode Island	19647 Caddock Electronics Inc. Riverside, California	24655 Genrad Inc. Concord, Massachusetts
15542 Scientific Components Corp. Mini-Circuits Laboratory Div. Brooklyn, New York	17338 High Pressure Eng. Co. Inc. Oklahoma City, Oklahoma	19701 Mepco/Centralab Inc. A N. American Philips Co. Mineral Wells, Texas	24759 Lenox-Fugle Electronics Inc. South Plainfield, New Jersey
15636 Elec-Trol Inc. Saugus, California	17545 Atlantic Semiconductors Inc. Asbury Park, New Jersey	20584 Enochs Mfg. Inc. Indianapolis, Indiana	24796 AMF Inc. Potter & Brumfield Div. San Juan Capistrano, Calif.
15782 Bausch & Lomb Inc. Graphics & Control Div. Austin, Texas	17745 Angstrom Precision, Inc. Hagerstown, Maryland	20891 Cosar Corp. Dallas, Texas	24931 Specialty Connector Co. Greenwood, Indiana
15801 Fenwal Electronics Inc. Div. of Kidde Inc. Framingham, Massachusetts	17856 Siliconix Inc. Santa Clara, California	21317 Electronics Applications Co. El Monte, California	25088 Siemen Corp. Isilen, New Jersey
15818 Teledyne Inc. Co. Teledyne Semiconductor Div. Mountain View, California	18178 E G & Gvactee Inc. St. Louis, Missouri	21604 Buckeye Stamping Co. Columbus, Ohio	25099 Cascade Gasket Kent, Washington
15849 Useco Inc. (Now 88245)	18324 Signetics Corp. Sacramento, California	21845 Solitron Devices Inc. Semiconductor Group Rivera Beach, Florida	25403 Amperex Electronic Corp. Semiconductor & Micro-Circuit Div. Slatersville, Rhode Island
15898 International Business Machines Corp. Essex Junction, Vermont	18520 Sharp Electronics Corp. Paramus, New Jersey	22526 DuPont, El DeNemours & Co. Inc. DuPont Connector Systems Advanced Products Div. New Cumberland, Pennsylvania	25706 Daburn Electronic & Cable Corp. Norwood, New Jersey
16245 Conap Inc. Olean, New York	18542 Wabash Inc. Wabash Relay & Electronics Div. Wabash, Indiana	22767 ITT Semiconductors Palo Alto, California	26629 Frequency Sources Inc. Sources Div. Chelmsford, Massachusetts
16258 Space-Lok Inc. Burbank, California	18565 Chomerics Inc. Woburn, Massachusetts	22784 Palmer Inc. Cleveland, Ohio	26806 American Zettler Inc. Irvine, California
16352 Codi Corp. Linden, New Jersey	18612 Vishay Intertechnology Inc. Vishay Resistor Products Group Malvern, Pennsylvania	23050 Product Comp. Corp. Mount Vernon, New York	27014 National Semiconductor Corp. Santa Clara, California
16469 MCL Inc. LaGrange, Illinois	18632 Norton-Chemplast Santa Monica, California	23732 Tracor Applied Sciences Inc. Rockville, Maryland	27167 Corning Glass Works Corning Electronics Wilmington, North Carolina
16473 Cambridge Scientific Industries Div. of Chemed Corp. Cambridge, Maryland	18677 Scanbe Mfg. Co. Div. of Zero Corp. El Monte, California	23880 Stanford Applied Engineering Santa Clara, California	27264 Molex Inc. Lisle, Illinois
	18736 Voltronics Corp. East Hanover, New Jersey		27440 Industrial Screw Products Los Angeles, California

Federal Supply Codes for Manufacturers (cont)

27745 Associated Spring Barnes Group Inc. Syracuse, New York	30800 General Instrument Corp. Capacitor Div. Hicksville, New York	33297 NEC Electronics USA Inc. Electronic Arrays Inc. Div. Mountain View, California	49956 Raytheon Company Executive Offices Lexington, Massachusetts
27956 Relcom (Now 14482)		33919 Nortek Inc. Cranston, Rhode Island	50088 Thomson Components-Mostek Corp. Carrollton, Texas
28198 Positronic Industries Springfield, Missouri	31019 Solid State Scientific Inc. Willow Grove, Pennsylvania	34333 Silicon General Inc. Garden Grove, California	50120 Eagle-Picher Industries Inc. Electronics Div. Colorado Springs, Colorado
28213 Minnesota Mining & Mfg. Co. Consumer Products Div. 3M Center Saint Paul, Minnesota	31091 Alpha Industries Inc. Microelectronics Div. Hatfield, Pennsylvania	34225 Advanced Micro Devices Sunnyvale, California	50157 Midwest Components Inc. Muskegon, Mississippi
28425 Serv-O-Link Eulless, Texas	31323 Metro Supply Company Sacramento, California	34359 Minnesota Mining & Mfg. Co. Commercial Office Supply Div. Saint Paul, Minnesota	50541 Hypertronics Corp. Hudson, Massachusetts
28478 Deltrol Corporation Deltrol Controls Div. Milwaukee, Wisconsin	31448 Army Safeguard Logistics Command Huntsville, Alabama	34371 Harris Corp. Harris Semiconductor Products Group Melbourne, Florida	50579 Litronix Inc. Cupertino, California
28480 Hewlett Packard Co. Corporate HQ Palo Alto, California	31746 Cannon Electric Woodbury, Tennessee	34649 Intel Corp. Santa Clara, California	51167 Aries Electronics Inc. Frenchtown, New Jersey
28484 Emerson Electric Co. Gearmaster Div. McHenry, Illinois	31827 Budwig Ramona, California	34802 Electromotive Inc. Kenilworth, New Jersey	51372 Verbatim Corp. Sunnyvale, California
28520 Heyco Molded Products Kenilworth, New Jersey	31918 ITT-Schadow Eden Prairie, Minnesota	34848 Hartwell Special Products Placentia, California	51406 Murata Erie, No. America Inc. (Also see 72982) Marietta, Georgia
29083 Monsanto Co. Santa Clara, California	32293 Intersil Cupertino, California	35009 Renfrew Electric Co. Ltd. IRC Div. Toronto, Ontario, Canada	51499 Amtron Corp. Boston, Massachusetts
29604 Stackpole Components Co. Raleigh, North Carolina	32539 Mura Corp. Westbury, Long Island, N.Y.	36665 Mitel Corp. Kanata, Ontario, Canada	51605 CODI Semiconductor Inc. Kenilworth, New Jersey
29907 Omega Engineering Inc. Stamford, Connecticut	32767 Griffith Plastics Corp. Burlingame, California	37942 Mallory Capacitor Corp. Sub of Emhart Industries Indianapolis, Indiana	51642 Centre Engineering Inc. State College, Pennsylvania
30035 Jolo Industries Inc. Garden Grove, California	32879 Advanced Mechanical Components Northridge, California	39003 Maxim Industries Middleboro, Massachusetts	51791 Statek Corp. Orange, California
30146 Symbex Corp. Painesville, Ohio	32897 Murata Eric North America Inc. Carlisle Operations Carlisle, Pennsylvania	40402 Roderstein Electronics Inc. Statesville, North Carolina	51984 NEC America Inc. Falls Church, Virginia
30148 AB Enterprise Inc. Ahoskie, North Carolina	32997 Bourns Inc. Trimpot Div. Riverside, California	42498 National Radio Melrose, Massachusetts	52063 Exar Integrated Systems Sunnyvale, California
30161 Aavid Engineering Inc. Laconia, New Hampshire	33096 Colorado Crystal Corp. Loveland, Colorado	43543 Nytronics Inc.(Now 53342)	52072 Circuit Assembly Corp. Irvine, California
30315 Iron Corp. San Diego, California	33173 General Electric Co. Owensboro, Kentucky	44655 Ohmite Mfg. Co. Skokie, Illinois	52152 Minnesota Mining & Mfg. Saint Paul, Minnesota
30323 Illinois Tool Works Inc. Chicago, Illinois	33246 Epoxy Technology Inc. Billerica, Massachusetts	49671 RCA Corp. New York, New York	52333 API Electronics Haugpaugue, Long Island, New York

Federal Supply Codes for Manufacturers (cont)

52361 Communication Systems Piscataway, New Jersey	54590 RCA Corp. Electronic Components Div. Cherry Hill, New Jersey	58104 Simco Atlanta, Georgia	64155 Linear Technology Milpitas, California
52525 Space-Lok Inc. Lercro Div. Burbank, California	55026 American Gage & Machine Co. Simpson Electric Co. Div. Elgin, Illinois	58474 Superior Electric Co. Bristol, Connecticut	64834 West M.G. Co. San Francisco, Calif.
52531 Hitachi Magnetics Edmore, Missouri	55112 Plessey Capacitors Inc. (Now 60935)	59124 KOA-Speer Electronics Inc. Bradford, Pennsylvania	65092 Sangamo Weston Inc. Weston Instruments Div. Newark, New Jersey
52745 Timco Los Angeles, California	55261 LSI Computer Systems Inc. Melville, New York	59640 Supertex Inc. Sunnyvale, California	65940 Rohm Corp & Whanney Irvine, California
52763 Stettner-Electronics Inc. Chattanooga, Tennessee	55285 Beroquist Co. Minneapolis, Minnesota	59660 Tusonix Inc. Tucson, Arizona	65964 Evox Inc. Bannockburn, Illinois
52769 Sprague-Goodman Electronics Inc. Garden City Park, New York	55576 Synertek Santa Clara, California	59730 Thomas and Betts Corp. Iowa City, Iowa	66150 Entron Inc. Winslow Teltronics Div. Glendale, New York
52771 Monitem Corp. Amatrom Div. Santa Clara, California	55680 Michicon/America/Corp. Schaumburg, Illinois	59831 Semtronics Corp. Watchung, New Jersey	66608 Bering Industries Fremont, California
52840 Western Digital Corp. Costa Mesa, California	56282 Utek Systems Inc. Olathe, Kansas	60395 Xicor Inc. Milpitas, California	70290 Almetal Universal Joint Co. Cleveland, Ohio
53021 Sangamo Weston Inc. (See 06141)	56289 Sprague Electric Co. North Adams, Massachusetts	60399 Torin Engineered Blowers Div. of Clevepak Corp. Torrington, Connecticut	70485 Atlantic India Rubber Works Inc. Chicago, Illinois
53217 Technical Wire Products Inc. Santa Barbara, California	56365 Square D Co. Corporate Offices Palatine, Illinois	60705 Cera-Mite Corp. (formerly Sprague) Grafton, Wisconsin	70563 Amperite Company Union City, New Jersey
53342 Opt Industries Inc. Phillipsburg, New Jersey	56375 DAL Industries Inc. Wescorp Div. Mountain View, California	60935 Westlake Capacitor Inc. Tantalum Div. Greencastle, Indiana	70903 Belden Corp. Geneva, Illinois
53944 Glow-Lite Pauls Valley, Oklahoma	56481 Shugart Associates Sub of Xerox Corp. Sunnyvale, California	61804 M/A Com Inc. Burlington, Massachusetts	71002 Bimbach Co. Inc. Farmingdale, New York
54294 Shallcross Inc. Smithfield, North Carolina	56708 Zilog Inc. Campbell, California	61857 SAN-O Industrial Corp. Bohemia, Long Island, NY	71034 Bliley Electric Co. Eric, Pennsylvania
54453 Sullins Electronic Corp. San Marcos, California	56856 Vamistor Corp. of Tennessee Sevierville, Tennessee	61935 Schurter Inc. Petaluma, California	71183 Westinghouse Electric Corp. Bryant Div. Bridgeport, Connecticut
54473 Matsushita Electric Corp. (Panasonic) Secaucus, New Jersey	56880 Magnetics Inc. Baltimore, Maryland	62351 Apple Rubber Lancaster, New York	71400 Bussman Manufacturing Div. McGraw-Edison Co. St. Louis, Missouri
54583 TDK Garden City, New York	57026 Endicott Coil Co. Inc. Binghamton, New York	62793 Lear Siegler Inc. Energy Products Div. Santa Ana, California	71450 CTS Corp. Elkhart, Indiana
54869 Pifer International Corp. Arlington Heights, Illinois	57053 Gates Energy Products Denver, Ohio	63743 Ward Leonard Electric Co. Inc. Mount Vernon, New York	71468 ITT Cannon Div. of ITT Fountain Valley, California
54937 DeYoung Mfg. Bellevue, Washington	58014 Hitachi Magnalock Corp. (Now 12581)	64154 Lamb Industries Portland, Oregon	71482 General Instrument Corp. Clare Div. Chicago, Illinois

Federal Supply Codes for Manufacturers (cont)

<p>71590 Mepco/Centralab A North American Philips Co. Fort Dodge, Iowa</p>	<p>73445 Amperex Electronic Corp. Hicksville, New York</p>	<p>75378 CTS Knights Inc. Sandwich, Illinois</p>	<p>79727 C - W Industries Southampton, Pennsylvania</p>
<p>71707 Coto Corp. Providence, Rhode Island</p>	<p>73559 Carlingswitch Inc. Hartford, Connecticut</p>	<p>75382 Kulka Electric Corp. (Now 83330) Mount Vernon, New York</p>	<p>79963 Zierick Mfg. Corp. Mount Kisco, New York</p>
<p>71744 General Instrument Corp. Lamp Div/Worldwide Chicago, Illinois</p>	<p>73586 Circle F Industries Trenton, New Jersey</p>	<p>75915 Tracor Littlefuse Des Plaines, Illinois</p>	<p>80009 Tektronix Beaverton, Oregon</p>
<p>71785 TRW Inc. Cinch Connector Div. Elk Grove Village, Illinois</p>	<p>73734 Federal Screw Products Inc. Chicago, Illinois</p>	<p>76854 Oak Switch Systems Inc. Crystal Lake, Illinois</p>	<p>80031 Mepco/Electra Inc. Morristown, New Jersey</p>
<p>71984 Dow Corning Corp. Midland, Michigan</p>	<p>73743 Fischer Special Mfg. Co. Cold Spring, Kentucky</p>	<p>77122 TRW Assemblies & Fasteners Group Fastener Div. Mountainside, New Jersey</p>	<p>80032 Ford Aerospace & Communications Corp. Western Development Laboratories Div. Palo Alto, California</p>
<p>72005 AMAX Specialty Metals Corp. Newark, New Jersey</p>	<p>73893 Microdot Mt. Clemens, Mississippi</p>	<p>77342 AMF Inc. Potter & Brumfield Div. Princeton, Indiana</p>	<p>80145 LFE Corp. Process Control Div. Clinton, Ohio</p>
<p>72136 Electro Motive Mfg. Corp. Florence, South Carolina</p>	<p>73899 JFD Electronic Components Div. of Murata Erie Oceanside, New York</p>	<p>77542 Ray-O-Vac Corp Madison, Wisconsin</p>	<p>80183 Sprague Products (Now 56289)</p>
<p>72228 AMCA International Corp. Continental Screw Div. New Bedford, Massachusetts</p>	<p>73905 FL Industries Inc. San Jose, California</p>	<p>77638 General Instrument Corp. Rectifier Div. Brooklyn, New York</p>	<p>80294 Boums Instruments Inc. Riverside, California</p>
<p>72259 Nytronics Inc. New York, New York</p>	<p>73949 Guardian Electric Mfg. Co. Chicago, Illinois</p>	<p>77900 Shakeproof Lock Washer Co. (Now 78189)</p>	<p>80583 Hammerlund Mfg. Co. Inc. Paramus, New Jersey</p>
<p>72619 Amperex Electronic Corp. Dialight Div. Brooklyn, New York</p>	<p>74199 Quam Nichols Co. Chicago, Illinois</p>	<p>77969 Rubbercraft Corp. of CA Ltd. Torrance, California</p>	<p>80640 Computer Products Inc. Stevens-Arnold Div. South Boston, Mass.</p>
<p>72653 G C Electronics Co. Div. of Hydrometals Inc. Rockford, Illinois</p>	<p>74217 Radio Switch Co. Marlboro, New Jersey</p>	<p>78189 Illinois Tool Works Inc. Shakeproof Div. Elgin, Illinois</p>	<p>81073 Grayhill Inc. La Grange, Illinois</p>
<p>72794 Dzus Fastner Co. Inc. West Islip, New York</p>	<p>74306 Piezo Crystal Co. Div. of PPA Industries Inc. Cardisle, Pennsylvania</p>	<p>78277 Sigma Instruments Inc. South Braintree, Mass.</p>	<p>81312 Litton Systems Inc. Winchester Electronics Div. Watertown, Connecticut</p>
<p>72928 Gulton Industries Inc. Gudeman Div. Chicago, Illinois</p>	<p>74542 Hoyt Elect.Instr. Works Inc. Penacook, New Hampshire</p>	<p>78290 Struthers Dunn Inc. Pitman, New Jersey</p>	<p>81439 Therm-O-Disc Inc. Mansfield, Ohio</p>
<p>72982 Murata Erie N. America Inc. Erie, Pennsylvania</p>	<p>74840 Illinois Capacitor Inc. Lincolnwood, Illinois</p>	<p>78553 Eaton Corp. Engineered Fastener Div. Cleveland, Ohio</p>	<p>81483 International Rectifier Corp. Los Angeles, California</p>
<p>73138 Beckman Industrial corp. Helipot Div. Fullerton, California</p>	<p>74970 Johnson EF Co. Waseca, Minnesota</p>	<p>78592 Stoeger Industries South Hackensack, New Jersey</p>	<p>81590 Korry Electronics Inc. Seattle, Washington</p>
<p>73168 Penwal Inc. Ashland, Massachusetts</p>	<p>75042 TRW Inc. IRC Fixed Resistors Philadelphia, Pennsylvania</p>	<p>79136 Waldes Kohinoor Inc. Long Island City, New York</p>	<p>81741 Chicago Lock Co. Chicago, Illinois</p>
<p>73293 Hughes Aircraft Co. Electron Dynamics Div. Torrance, California</p>	<p>75297 Litton Systems Kester Solder Div. Chicago, Illinois</p>	<p>79497 Western Rubber Co. Goshen, Indiana</p>	<p>82227 Airpax Corp. Cheshire Div. Cheshire, Connecticut</p>
	<p>75376 Kurz-Kasch Inc. Dayton, Ohio</p>		<p>82240 Simmons Fastner Corp. Albany, New York</p>

Federal Supply Codes for Manufacturers (cont)

82305 Palmer Electronics Corp. South Gate, California	84171 Arco Electronics Commack, New York	89536 John Fluke Mfg. Co., Inc. Everett, Washington	91802 Industrial Devices Inc. Edgewater, New Jersey
82389 Switchcraft Inc. Sub of Raytheon Co. Chicago, Illinois	84411 American Shizuki TRW Capacitors Div. Ogallala, Nebraska	89597 Fredericks Co. Huntingdon Valley, Penna.	91833 Keystone Electronics Corp. New York, New York
82415 Airpax Corp Frederick Div. Frederick, Maryland	84613 FIC Corp. Rockville, Maryland	89709 Bunker Ramo-Eltra Corp. Amphenol Div. Broadview, Illinois	91836 King's Electronics Co. Inc. Tuckahoe, New York
82872 Roanwell Corp. New York, New York	84682 Essex Group Inc. Peabody, Massachusetts	89730 General Electric Lamp Div. Newark, New Jersey	91929 Honeywell Inc. Micro Switch Div. Freeport, Illinois
82877 Rotron Inc. Custom Div. Woodstock, New York	85367 Bearing Distributing Co. San Francisco, California	90201 Mallory Capacitor Co. Sub of Emhart Industries Inc. Indianapolis, Indiana	91934 Miller Electric Co. Woonsocket, Rhode Island
82879 ITT Royal Electric Div. Pawtucket, Rhode Island	85372 Bearing Sales Co. Los Angeles, California	90215 Best Stamp & Mfg. Co. Kansas City, Missouri	91984 Maida Development Co. Hampton, Virginia
83003 Varo Inc. Garland, Texas	85480 W. H. Brady Co. Industrial Product Milwaukee, Wisconsin	90303 Duracell Inc. Technical Sales & Marketing Bethel, Connecticut	91985 Norwalk Valve Co. S. Norwalk, Connecticut
83014 Hartwell Corp. Placentia, California	85932 Electro Film Inc. Valencia, California	91094 Essex Group Inc. Suflex/IWP Div. Newmarket, New Hampshire	92914 Alpha Wire Corp. Elizabeth, New Jersey
83055 Signalite Fuse Co. (Now 71744)	86577 Precision Metal Products Co. Peabody, Massachusetts	91247 Illinois Transformer Co. Chicago, Illinois	93332 Sylvania Electric Products Semiconductor Products Div. Woburn, Massachusetts
83058 TRW Assemblies & Fasteners Group Fasteners Div. Cambridge, Massachusetts	86684 Radio Corp. of America (Now 54590)	91293 Johanson Mfg. Co. Boonton, New Jersey	94144 Raytheon Co. Microwave & Power Tube Div. Quincy, Massachusetts
83259 Parker-Hannifin Corp. O-Seal Div. Culver City, California	86928 Seastrom Mfg. Co. Inc. Glendale, California	91462 Alpha Industries Inc. Logansport, Indiana	94222 Southco Inc. Concordville, Pennsylvania
83298 Bendix Corp. Electric & Fluid Power Div. Eatonville, New Jersey	87034 Illuminated Products Inc. (Now 76854)	91502 Associated Machine Santa Clara, California	94988 Wagner Electric Corp. Sub of McGraw-Edison Co. Whippany, New Jersey
83315 Hubbell Corp. Mundelein, Illinois	88219 GNB Inc. Industrial Battery Div. Langhorne, Pennsylvania	91506 Augat Inc. Attleboro, Massachusetts	95146 Alco Electronic Products Inc. Switch Div. North Andover, Massachusetts
83330 Kulka Smith Inc. A North American Philips Co. Manasquan, New Jersey	88245 Winchester Electronics Litton Systems-Useco Div. Van Nuys, California	91507 Froeliger Machine Tool Co. Stockton, California	95263 Leecraft Mfg. Co. Long Island City, New York
83478 Rubbercraft Corp. of America West Haven, Connecticut	88486 Triangle PWC Inc. Jewitt City, Connecticut	91637 Dale Electronics Inc. Columbus, Nebraska	95275 Vitramon Inc. Bridgeport, Connecticut
83553 Associated Spring Barnes Group Gardena, California	88690 Essex Group Inc. Wire Assembly Div. Dearborn, Michigan	91662 Elco Corp. A Gulf Western Mfg. Co. Connector Div. Huntingdon, Pennsylvania	95303 RCA Corp. Receiving Tube Div. Cincinnati, Ohio
83740 Union Carbide Corp. Battery Products Div. Danbury, Connecticut	89020 Amerace Corp. Buchanan Crimptool Products Div. Union, New Jersey	91737 ITT Cannon/Gremar (Now 08718)	95348 Gordo's Corp. Bloomfield, New Jersey
	89265 Potter-Brumfield (See 77342)		95354 Methode Mfg. Corp. Rolling Meadows, Illinois

Federal Supply Codes for Manufacturers (cont)

95573
Campion Laboratories Inc.
Detroit, Michigan

95712
Bendix Corp.
Electrical Comp. Div.
Franklin, Indiana

95987
Weckesser Co. Inc.
(Now 85480)

96733
SFE Technologies
San Fernando, California

96853
Gulton Industries Inc.
Measurement & Controls Div.
Manchester, New Hampshire

96881
Thomson Industries Inc.
Port Washington, New York

97525
EECO Inc.
Santa Ana, California

97540
Whitehall Electronics Corp.
Master Mobile Mounts Div.
Fort Meyers, Florida

97913
Industrial Electronic
Hardware Corp.
New York, New York

97945
Pennwalt Corp.
SS White Industrial Products
Piscataway, New Jersey

97966
CBS
Electronic Div.
Danvers, Massachusetts

98094
Machlett Laboratories Inc.
Santa Barbara, California

98159
Rubber-Teck Inc.
Gardena, California

98278
Malco A Microdot Co.
South Pasadena, California

98291
Sealectro Corp.
BICC Electronics
Trumbull, Connecticut

98372
Royal Industries Inc.(Now 62793)

98388
Lear Siegler Inc.
Accurate Products Div.
San Deigo, California

99120
Plastic Capacitors Inc.
Chicago, Illinois

99217
Bell Industries Inc.
Elect. Distributor Div.
Sunnyvale, California

99378
ATLEE of Delaware Inc.
N. Andover, Massachusetts

99392
Mepco/Electra Inc.
Roxboro Div.
Roxboro, North Carolina

99515
Electron Products Inc.
Div. of American Capacitors
Duarte, California

99779
Bunker Ramo- Eltra Corp.
Barnes Div.
Lansdown, Pennsylvania

99800
American Precision Industries
Delevan Div.
East Aurora, New York

99942
Mepco/Centralab
A North American Philips Co.
Milwaukee, Wisconsin

INTERNATIONAL SALES OFFICES

Argentina •

Coasin S.A.
Virrey del Pino 4071 DPTO E-65
1430 CAP FED
Buenos Aires, Argentina
Tel: 54-1-552-5248
TLX: (390) 22284 COASN AR

Asia

Fluke Asia Ltd.
Shun Tak Centre, Room 1501
200 Connaught Road
Central, Hong Kong
Tel: 852 5 482116
TLX: (780) 87058 FLUKE
FAX: (852) 5-479863

Australia •

Elmeasco Instruments Pty. Ltd.
P.O. Box 30
Concord, N.S.W. 2137
Australia
Tel: 61-2-736-2888
TLX: (790) 25887 A/B: ELSCOAA 25887
FAX: 61-2-733663

Elmeasco Instruments Pty. Ltd.
P.O. Box 623
12 Maroondah Highway
Ringwood, Victoria 3134
Australia
Tel: 61-3-879-2322
TLX: (790) 30418 A/B: ELTENTAA 30418
FAX: (61) (3) 879-4310

Elmeasco Instruments Pty. Ltd.
P.O. Box 274
Salisbury, Queensland 4107
Australia
Tel: 61-7-875-1444
TLX: (790) 44062 A/B: ELMQLDAA44062

Elmeasco Instruments Pty. Ltd.
P.O. Box 154
Prospect, South Australia 5082
Tel: 61-8-344-9000 TLX: (790) A/B:87519

Elmeasco Instruments Pty. Ltd.
P.O. Box 413
Scott House
46-48 Kings Park Road
West Perth, Western Australia 6005
Australia
Tel: 61-9-481-1500
TLX: (790) 94765 A/B: ASECSAA 94765
FAX: (61) (9) 322-2075

Austria ■

Walter Rekirsch Elektronische
Geräte GmbH & Co.
Vertrieb KG
Obachgasse 28
1220 Vienna, Austria
Tel: 43-222-25-36-26
TLX: (847) 134759
FAX: 43-222-25-72-75

Bahrain •

Basma W.L.L.
P.O. Box 5701
Manama, Bahrain
Tel: 973-251364; TLX: (955) 9003
FAX: (965) 245218

Bangladesh •

Motherland Corporation
24 Hatkhola Road, Tikatuli
Dacca-3, Bangladesh
Tel: 257249
TLX: (950) 642022 PCO BJ
Cable: "MOTHERLAND" DACCA

Belgium ■

N.V. Philips
Industrial & Electro-Acoustic Systems
5600 MD Eindhoven
The Netherlands
Tel: 040-785539
Tlx: 35000 phtc nl
Fax: 040-785651

Bolivia •

Coasin Bolivia S.R.L.
Casilla 7295
La Paz, Bolivia
Tel: 591-2-40962
TLX: (336) 3233 COALAP BV
Cable: COALAP

Brazil •

ATP/Hi-Tek Eletronica Ltda.
Al. Amazonas 422,
Alphaville, 06400, Barueri
Sao Paulo, Brazil
Tel: 55-11-421-5477;
TLX: (391) 1171413 HITK BR

Brunei •

Rank O'Connor's SDN BHD
No. 8 Blok D
Sufri Shophouse Complex
Mile 1 Jalan Tutong
Bandar Seri Begawan
Negara Brunei Darussalam
Tel: 673-2-23109 or 23557
TLX: (799) BU 2265 RANKOC

Canada •

Fluke Electronics Canada Inc.
101, 1144 - 29th Avenue N.E.
Calgary, Alberta T2E 7P1
Canada
Tel: (403) 291-5215
Fax: (403) 291-5219

Fluke Electronics Canada Inc.
400 Britannia Road East
Unit #1
Mississauga, Ontario L4Z 1X9
Tel: (416) 890-7600
Fax: (416) 890-6866

Fluke Electronics Canada Inc.
1255 Trans Canada Hwy.
Suite 130
Dorval, Quebec
H9P 2V4 Canada
Tel: (514) 685-0022
TLX: (514) 685-0039

Fluke Electronics Canada Inc.
1690 Woodward Drive
Suite 216
Ottawa, Ontario
K2C 3R8 Canada
Tel: (613) 723-9453
Fax: (613) 723-9458

Chile •

Intronica Chile, Ltda.
Casilla 16228 (Mail)
Santiago 9, Chile
Tel: 56-2-2321886
TLX: (332) 346351 INTRON CK

China, Peoples Republic of •

Fluke International Corporation
P.O. Box 9085
Beijing
People's Republic of China
Tel: 86-01-65-7281
TLX: (716) 222237 FBSC CN
Instrimpex - Fluke Service Center
57, Xisi Dong Da Jie
Xicheng-qu
Beijing
Peoples Republic of China
Tel: 86-01-65-7281

Colombia •

Sistemas E Instrumentacion, Ltda.
Carrera 13, No. 37-43, Of. 401
Ap. Aereo 29583
Bogota DE, Colombia
Tel: 57-232-4532
TLX: (396) 45787 COASN CO

Cyprus ■

Chris Radiovision, Ltd.
P.O. Box 1989
Nicosia, Cyprus
Tel: 357-21-66121; TLX: (826) 2395

Cyprus, Northern ■

Ucok Buroteknik
2C & 2D Muftu Ziyai Street
Lefkosa, Northern Cyprus
Mersin 10, Turkey
Tel: 90-741-357-20-71777
TLX: (821) 57267

Czechoslovakia ■

Amtest Associates, Ltd.
Amtest House
75-79 Guildford Street
Chertsey, Surrey KT16 9AS
England
Tel: 44-9328-68355
TLX: (851) 928855 AMTEST G
Fax: 44-9328-61919

Denmark ■

Tage Olsen A/S
Ballerup Byvej 222
2750 Ballerup
Denmark
Tel: 45-2-658111
TLX: (855) 35293 TOAS DK

Eastern European Countries ■

Amtest Associates, Ltd.
Amtest House
75-79 Guildford Street
Chertsey, Surrey KT16 9AS
England
Tel: 44-9328-68355
TLX: (851) 928855 AMTEST G
Fax: 44-9328-61919

German Branch Office

Amtest Associates, Ltd.
Zugspitzstrasse 2A
P.O. Box 1107
8011 Vaterstetten
West Germany
Tel: 49-81-067117; TLX: (841) 528332

Ecuador •

Proteco Coasin Cia., Ltda.
P.O. Box 228-A
Ave. 12 de Octubre 2285
y Orellana
Quito, Ecuador
Tel: 593-2-529684
TLX: (393) 22085 ESIND

Egypt

Electronic Engineering Liaison Office
P.O. Box 2891 Horreya
11361 Heliopolis, Cairo
Egypt
Tel: 20-2-695705; TLX: (927) 22782

England

N.V. Philips
Industrial & Electro-Acoustic Systems
5600 MD Eindhoven
The Netherlands
Tel: 040-785539
Tlx: 35000 phtc nl
Fax: 040-785651

Fiji •

Awa New Zealand Limited
37 Freeston Road
Wailu Bay, P.O. Box 858
Suva, Fiji
Tel: 679-312079; TLX: (792) FJ2347
FAX: 679-314379

Finland ■

Instrumentarium Elektronika
P.O. Box 64
02631 Espoo 63
Finland
Tel: 358-0-5281
TLX: (857) 124426 HAVUL SF
FAX: (358) 0-5021073
Teletex: (857) 8-100155 INSTRUE

France ■

M.B. Electronique S.A.
606, Rue Fournay
P.O. Box 31
78530 BUC, France
Tel: 33-1-39-56-81-31
TLX: (842) 695414
Fax: (33) (1) 3956-53-44

German Branch Office

Amtest Associates, Ltd.
Zugspitzstrasse 2A
P.O. Box 1107
8011 Vaterstetten
West Germany
Tel: 49-81-067117
TLX: (841) 528332

Germany, West

N.V. Philips
Industrial & Electro-Acoustic Systems
5600 MD Eindhoven
The Netherlands
Tel: 040-785539
Tlx: 35000 phtc nl
Fax: 040-785651

Greece

Hellenic Scientific Representations Ltd.
11, Vrassida Street
Athens 612, Greece
Tel: 30-1-7211140; TLX: (863) 219330

Hong Kong •

Schmidt & Co (H.K.), Ltd
18th Floor, Great Eagle Centre
23 Harbour Road
Wanchai, Hong Kong
Tel: 852-5-8330-222
TLX: (780) 74766 SCHMC HK
FAX: 852-5-8918754

India •

Hinditron Services Pvt., Ltd.
69/A.L. Jagmohandas Marg
Bombay 400 006, India
Tel: 91-22-8121316, 8125344
TLX: (953) 1175326 HSPL IN

Bangalore Office
Hinditron Services Pvt., Ltd.
8th Main Road
33/44A Raj Mahal Vilas Extension
Bangalore 560 080, India
Tel: 91-812-363139
TLX: (953) 08452741
Cable: TEKHIND BANGALORE

Calcutta Office
Hinditron Services Pvt. Ltd.
5th Floor, Castle House
5/1A, Hungerford St.
Calcutta 700 017, India
Tel: 91-33-432628
TLX: (953) 214153

New Delhi Sales
Hinditron Services Pvt. Ltd.
204-206 Hemkunt Tower
98 Nehru Place
New Delhi, 110019, India
Tel: 91 (11) 6410380 or 6414493
TLX: (953) 3161458 HSPL IN

New Delhi Service
Hinditron Services Pvt., Ltd.
Field Service Center
15, Community Centre
Panchshila Park
New Delhi 110 017, India
Tel: 91 011 6433675

Cable: Tekcentre Delhi
Hyderabad Office
Hinditron Services Pvt. Ltd.
Field Service Center
Emerald Complex, 5th Floor
1-7-264
114 Sarojini Devi Road
Secunderabad 500 003, India
Tel: 91 842 821117
TLX: (953) 04256973 HSPL IN

Indonesia •

P.T. Lamda Triguna
P.O. Box 6/JATJG
Jakarta, 13001
Indonesia
Tel: 62 21 8195365
TLX: (796) 46171 LAYARIA

Iran ■

Arma Baynelmeleli Co., Ltd.
P.O. Box 951570
Pasdaran-Tehran
Tel: 98-21-248717; TLX: (951) 213648

Ireland

N.V. Philips
Industrial & Electro-Acoustic Systems
5600 MD Eindhoven
The Netherlands
Tel: 040-785539
Tlx: 35000 phtc nl
Fax: 040-785651

Israel ■

R.D.T. Electronics Engineering Ltd.
P.O. Box 43137
Tel Aviv 61430
Israel
Tel: (3) 972-3-483211
TLX: (922) 371452 RDT IL
Fax: 972-3-492190

Italy ■

Sistrel S.p.A.
Via le Erminio Spalla 41
00142 Rome, Italy
Tel: 39-6-504-1367; TLX: (843) 625857
Fax: (39) 6-504137



John Fluke Mfg. Co., Inc. / PO Box C9090 / Everett, WA 98206 / (206) 356 5400

Litho in U.S.A. 11/87

U.S. SALES OFFICE AREAS

AL, Huntsville

John Fluke Mfg. Co., Inc.
4920J Corporate Drive
Huntsville, AL 35805-6202
(205) 837-0581

AZ, Phoenix

John Fluke Mfg. Co., Inc.
2211 S. 48th Street
Suite B
Tempe, AZ 85282
(602) 438-8314

Tucson

(602) 790-9881

CA, Southern

John Fluke Mfg. Co., Inc.
P.O. Box 19676
Irvine, CA 92713-9676
16969 Von Karman
Suite 100
Irvine, CA 92714
(714) 863-9031

Burbank

John Fluke Mfg. Co., Inc.
2020 N. Lincoln Street
Burbank, CA 91504
(213) 849-7181

Northern

John Fluke Mfg. Co., Inc.
2300 Walsh Ave., Bldg. K
Santa Clara, CA 95051
(408) 727-0513

San Diego

(619) 292-7656

CO, Denver

John Fluke Mfg. Co., Inc.
14180 East Evans Ave.
Aurora, CO 80014
(303) 695-1000

CT, Hartford

John Fluke Mfg. Co., Inc.
Glen Locken East
41-C New London Turnpike
Glastonbury, CT 06033
(203) 659-3541

DC, Washington

(301) 770-1570

FL, Clearwater

(813) 799-0087

Miami

(305) 462-1380

Orlando

John Fluke Mfg. Co., Inc.
940 N. Fern Creek Ave.
Orlando, FL 32803
(305) 896-4881

Tampa

(813) 251-9211

GA, Atlanta

John Fluke Mfg. Co., Inc.
2700 Deik Rd., Suite 150
Marietta, GA 30067
(404) 953-4747

IL, Chicago

John Fluke Mfg. Co., Inc.
1150 West Euclid Ave.
Palatine, IL 60067
(312) 705-0500

IN, Indianapolis

John Fluke Mfg. Co., Inc.
8777 Purdue Rd.
Suite 101
Indianapolis, IN 46268
(317) 875-7870

LA, Baton Rouge

(504) 924-1203

New Orleans

(504) 455-0814

MA, Boston

John Fluke Mfg. Co., Inc.
Middlesex Tech Center
900 Middlesex Turnpike
Building 8
Billerica, MA 01821
(617) 663-2400

MD, Baltimore

(301) 792-7060

Rockville

John Fluke Mfg. Co., Inc.
5640 Fishers Lane
Rockville, MD 20852
(301) 770-1570

MI, Detroit

John Fluke Mfg. Co., Inc.
33031 Schoolcraft
Livonia, MI 48150
(313) 522-9140

MN, Bloomington

John Fluke Mfg. Co., Inc.
1801 E. 79th St., Suite 9
Bloomington, MN 55420
(612) 854-5526

MO, St. Louis

John Fluke Mfg. Co., Inc.
11756 Borman Drive
Suite 160
St. Louis, MO 63146
(314) 993-3805

NC, Greensboro

John Fluke Mfg. Co., Inc.
1310 Beaman Place
Greensboro, NC 27408
(919) 273-1918

NJ, Paramus

John Fluke Mfg. Co., Inc.
P.O. Box 930
Paramus, NJ 07653-0930
West 75 Century Road
Paramus, NJ 07652
(201) 262-9550

NM, Albuquerque

(505) 881-3550

NY, Rochester

John Fluke Mfg. Co., Inc.
4515 Culver Road
Rochester, NY 14622
(716) 323-1400

OH, Cleveland

John Fluke Mfg. Co., Inc.
7830 Freeway Circle
Middleburg Heights, OH 44130
(216) 234-4540

Dayton

John Fluke Mfg. Co., Inc.
5450 Far Hills Avenue
Suite 111
Kettering, OH 45429
(513) 436-2224

OK, Northeast

(918) 749-0190

OR, Portland

(503) 227-2042

PA, Philadelphia

John Fluke Mfg. Co., Inc.
200 Lindenwood Drive
Malvern, PA 19355
(215) 647-9550

Pittsburgh

(412) 261-5171

TX, Austin

(512) 459-3344

Dallas

John Fluke Mfg. Co., Inc.
1801 Royal Lane
Suite 307
Dallas, TX 75229
(214) 869-0311

El Paso

(915) 533-3508

Houston

(713) 240-5995

San Antonio

John Fluke Mfg. Co., Inc.
10417 Gulfdale
San Antonio, TX 78216
(512) 340-0498

UT, Salt Lake City

(801) 268-9331

WA, Seattle

John Fluke Mfg. Co., Inc.
5020 148th Ave. N.E.
Suite #110
Redmond, WA 98052
(206) 881-6966

U.S. Government Specialists

Army (301) 770-1570, MD
(203) 837-0581, AL

Navy (714) 863-9031, CA
(301) 770-1570, MD

USAF (513) 436-2224, OH
(512) 340-2621, TX

Security (301) 770-1570, MD

Service Center Areas

CA, Burbank (213) 849-4641

CA, Santa Clara (408) 727-0513

CO, Denver (303) 695-1000

FL, Orlando (305) 896-4881

IL, Chicago (312) 705-0500

MD, Rockville (301) 770-1576

NJ, Paramus (201) 262-9550

TX, Dallas (214) 869-2848

WA, Everett (206) 356-5560

For more information on Fluke products or Sales Offices you may dial (800) 426-0361 toll-free in most of the U.S.A.
From Alaska, Hawaii, or Washington phone (206) 356-5400. From Canada and other countries phone (206) 356-5500.



John Fluke Mfg. Co., Inc., P.O. Box C9090, Everett, WA 98206
Fluke (Holland) B.V., P.O. Box 2269, 5600 CG, Eindhoven, The Netherlands. Phone (040) 458045
Litho in U.S.A. 11/87

Milan Office
Sistrel S.p.A.
Via Pelizza da Volpedo 59
20092 Cinisello Balsamo
Milan, Italy
Tel: 39-2-6181893, TLX: (843) 334643
Fax: (39) 2-6182440

Naples Office
Sistrel S.p.A.
Via Cintia
Parco S. Paolo 35
80126 Naples, Italy
Tel: 39-81-7678700
Fax: (39) 81-7661361

Japan ●
John Fluke Mfg. Co., Inc.
Japan Branch
Sumitomo Higashi Shinbashi Bldg.
1-1-11 Hamamatsucho
Minato-ku, Tokyo 105, Japan
Tel: 81-3-434-0181
TLX: (781) 2424331 FLUK JPY
FAX: 81-3-434-0170

Osaka Sales Office
John Fluke Mfg. Co., Inc.
Japan Branch
Katsushige Building
2-45 Kohrabashi
Higashi-ku, Osaka 541
Japan
Tel: 81-6-229-0871 FAX: 81-6-229-1098

Korea, Republic of ●
Myoung Corporation
Yeo Eui Do P.O. Box 14
Seoul, Korea
Tel: 82-2-784-9942 MYOUNG
TLX: (787) K24283
FAX: (82) 2-784-2387

Kuwait ●
Al Bahar International Group
P.O. Box 26672 Safat
13127 Safat, Kuwait
Kuwait, Arabian Gulf
Tel: 965-848601, 847598
TLX: (959) 44822

Lebanon and Jordan ●
Mabek (Electronics Division)
P.O. Box 13-5657
Beirut, Lebanon
Tel: 812523
TLX: (923) 22889 LIBANK LE

Malaysia ●
Mecomb Malaysia Sdn Bhd
P.O. Box 24
46700 Petaling Jaya, Selangor, Malaysia
Tel: 60-3-774-3422
TLX: (784) MA37764 MECOMB
Fax: (6) 03-774-3414

Malta ●
Fabian Enterprises
20, Msida Road
Gzira, Malta
Tel: 513283/40216, TLX: (838) 1837

Mexico ●
Mexicana de Electronica
Industrial, S.A. (Mixel)
Diagonal No. 27
Entre Calle de Eugenia Y Ave
Colonia del Valle
C.P. 03100, Mexico
Tel: (905) 660-4323
TLX: (383) 1771038 FAIRME

Executone De Monterrey, S.A.
Ave. Gonzalitos NTE 545
Monterrey N.L., Mexico
Tel: 90-5-480400, 472625
TLX: (383) 382659

Morocco ●
Oussama S.A.
Angle Boulevard Emile Zola et
Rue Rethel
P.O. Box 2007 Casa
Casablanca
Morocco
Tel: 212-24-13-38, TLX: (933) 28879 M

Nepal ●
Associated Enterprises
GPO Box 790, Pyaphal Tole
Kathmandu, Nepal
Tel: 13868, TLX: (947) 2568 (ASOENT NP)

Netherlands
N.V. Philips
Industrial & Electro-Acoustic Systems
5600 MD Eindhoven
The Netherlands
Tel: 040-785539
Tlx: 35000 phtc nl
Fax: 040-785651

New Zealand ●
Auckland Office
Northrop Instruments & Systems, Ltd
459 Khyber Pass Road
Private Bag, Newmarket
Auckland 1, New Zealand
Tel: 64-9-501-801, 501-219
TLX: (791) 21570
FAX: 64-9-543430

Wellington Office
Northrop Instruments & Systems Ltd.
Information Technology Group
First Floor, Northrop Bldg.
189-191 Willis Street
P.O. Box 2406
Wellington, New Zealand
Tel: 64-4-856-658
TLX: (791) 3380

Christchurch Office
Northrop Instruments & Systems Ltd.
Information Technology Group
110 Mandeville Street
P.O. Box 8388
Christchurch, New Zealand
Tel: 64-3-488-874
TLX: (791) 4801

Norway ●
Morgenstjerne & Co A/S
Konghellegate 3
P.O. Box 6688, Rodelokka
Oslo 5, Norway
Tel: (2) 356110, TLX: (856) 71719

Oman ●
OHI Telecommunications LLC
P.O. Box 889
Muscat, Oman
Tel: 968-603606
TLX: (926) 5052 TELECOM ON

Pakistan ●
International Operations (PAK), Ltd.
505 Muhammadi House
I.I. Chundrigar Road
P.O. Box 5323, Karachi, Pakistan
Tel: 92-21-221127, TLX: (952) 24494 PIO PK

Peru ●
Importaciones y Representaciones
Electronicas S.A.
Ayda, Franklin D. Roosevelt 105
Lima 1, Peru
Tel: 51-14-28-8650
TLX: (394) 25663 PE IREING

Philippines, Republic of ●
Spark Radio & Electronics, Inc.
Greenhills P.O. Box 610
San Juan, Metro Manila, Zip 3113
Philippines
Tel: 63-2-775192, 704096
TLX: (722 or 732) 27901 RLA PH

Portugal ●
Decada Espectral
Equipamentos de Electronica
Av. Bombeiros Voluntarios
Lote 102B, Miraflores/Alges
1495 Lisbon, Portugal
Tel: 351-1-4103420, TLX: (832) 15515

Romania ●
Amtest Associates Ltd.
Amtest House
75-79 Guildford Street
Chertsey, Surrey KT16 9AS
England
Tel: 44-9328-68355, TLX: (851) 928855
FAX: 44-9328-61919

Saudi Arabia ●
Electronic Equipment Marketing Co.
P.O. Box 3750
Riyadh, Saudi Arabia
Tel: 966-1-477-1650
TLX: (928) 401120 ZUHAIR SJ

Scotland
N.V. Philips
Industrial & Electro-Acoustic Systems
5600 MD Eindhoven
The Netherlands
Tel: 040-785539
Tlx: 35000 phtc nl
Fax: 040-785651

Singapore, Republic of ●
Rank O'Connor's (PTE) Ltd.
O'Connor House
98 Pasir Panjang Road
Singapore 0511
Republic of Singapore
Tel: 65-4737944, TLX: (786) RS21023 OCONSN
FAX: 4724508 CABLE CINECOM SINGAPORE

South Africa ●
Protea PNI
P.O. Box 39127
Bramley 2018
Republic of South Africa
Tel: 27-11-786-3647
TLX: (960) 4-24409 SA
FAX 27-11-786-1807

Spain ●
ESSA
Equipos y Sistemas S.A.
C/Apolonio Morales, 13-B
Madrid 16, Spain
Tel: 34-1-458-0150
TLX: (831) 42856 EYS E

Sri Lanka ●
Computerlink Data Systems, Ltd.
331 Union Place
Colombo 2, Sri Lanka
Tel: 94-1-28641
TLX: (954) 22455 COLINK CE

Sweden
N.V. Philips
Industrial & Electro-Acoustic Systems
5600 MD Eindhoven
The Netherlands
Tel: 040-785539
Tlx: 35000 phtc nl
Fax: 040-785651

Switzerland ●
Traco Electronic AG
Jenatschstrasse 1
8002 Zurich
Switzerland
Tel: 41-1-201-0711
TLX: (845) 815570 TRCOCH

Syria ●
Mabek (Electronics Division)
P.O. Box 4238
Damascus, Syria

Taiwan ●
Schmidt Electronics Corp.
5th Fl, Cathay Min Sheng
Commercial Building,
344 Min Sheng East Road
Taipei Taiwan R.O.C.
Tel: 886-2-501-3468
TLX: (785) 11111 SCHMIDT
Fax: (886) 2-502-9692

Thailand ●
Measuretronix Ltd.
2102/63 Ramkamhaeng Rd.
Huamark Bangkok 10240
Thailand
Tel: 66 (2) 3742516, 3741632
TLX: (788) 82796 HUAMARK TH

Tunisia ●
Selep S.A.R.L.
6, Rue de Sparte
Tunis - 1000 RP
Tunisia
Tel: 216-1-248093, TLX: (934) 13030

Turkey ●
Erkman Elektronik Aletler
Ticaret Anonim Sirketi
Necatibey Cad 92/3
Karakoy, Istanbul, Turkey
Tel: 90 (11) 441546, TLX: (821) 24399

United Arab Emirates ●
Harris Al-Afaq, Ltd.
P.O. Box 8141
Kamal Hamza Bldg.
Traffic Police Road
Dubai, U.A.E.
Tel: 971-4-283625
TLX: (958) 48168 AFAQEM

Al-Sanani Cen. Trad Est.
P.O. Box 7187
Abu-Dhabi, U.A.E.
Tel: 971-2-821370, TLX: (958) 23966

Uruguay ●
Coasin Uruguaya S.A.
Casilla de Correo 1400
Libertad 2529
Montevideo, Uruguay
Tel: 598-2-789204, 789015
TLX: (398) UY23010 COAUR

USSR
Amtest Associates Ltd.
Amtest House
75-79 Guildford Street
Chertsey, Surrey KT16 9AS
England
Tel: 44-9328-68355, TLX: (851) 928855
FAX: 44-9328-61919

Venezuela ●
Coasin C.A.
Calle 9 Con Calle 4, Edif Edinurbi
Apartado de Correos NR-70.136
Los Ruices
Caracas 1070-A, Venezuela
Tel: 58 (2) 241-03-09
TLX: (395) 21027 EMVEN VC

Yugoslavia ●
Amtest Associates Ltd.
Amtest House
75-79 Guildford Street
Chertsey, Surrey KT16 9AS
England
Tel: 44-9328-68355, TLX: (851) 928855
FAX: 44-9328-61919

● **Supplied and Supported by** —
Fluke (Holland) B.V.
P.O. Box 2269
5600 CG Eindhoven
The Netherlands
Tel: (040) 45805, TLX: (844) 51846
FAX: 31-40-457515

● **Supplied and Supported by** —
Fluke International Corporation
P.O. Box C9090
Everett, WA 98206 U.S.A.
Tel: (206) 356-5500
TLX: 185103 FLUKE UT
FAX: 206-356-5116

The following countries are
represented by:
Fluke (Holland) B.V.
P.O. Box 2269
5600 CG Eindhoven
The Netherlands
Tel: (040) 45805, TLX: 51846
FAX: 31-40-457515

Abu Dhabi	Mauritania
Afghanistan	Menorca
Albania	Mongolia
Algeria	Niger
Angola	Nigeria
Benin	Qatar
Bornholm	Rodhos
Botswana	Russia
Chad	Sardinia
Corsica	Saudia Arabia
Czechoslovakia	Scotland
Dubai	Senegal
Ethiopia	Sierra Leone
Guinea	Somalia
Ibiza	Togo
Iceland	Upper Volta
Iraq	Wales
Kuwait	Wstn Sahara
Liberia	Yemen
Libya	Zaire
Luxembourg	Zambia
Maderia	Zimbabwe
Mallorca	

TECHNICAL SERVICE CENTERS

U.S.A.

CA, Burbank
John Fluke Mfg. Co., Inc.
(213) 849-4641

CA, Santa Clara
John Fluke Mfg. Co., Inc.
(408) 727-8121

CO, Denver
John Fluke Mfg. Co., Inc.
(303) 695-1000

FL, Orlando
John Fluke Mfg. Co., Inc.
(305) 896-4881

IL, Palatine
John Fluke Mfg. Co., Inc.
(312) 705-0500

MD, Rockville
John Fluke Mfg. Co., Inc.
(301) 770-1576

NJ, Paramus
John Fluke Mfg. Co., Inc.
(201) 262-9550

TX, Dallas
John Fluke Mfg. Co., Inc.
(214) 869-0311

WA, Seattle
John Fluke Mfg. Co., Inc.
(206) 356-5560

Other Countries

Argentina, Buenos Aires
Coasin S.A.
Tel: 552-5248
TLX: (390) 22284

Australia, Brisbane
Elmeasco Instruments Pty. Ltd.
Tel: 552-5248

Australia, Concord
Elmeasco Instruments Pty. Ltd.
Tel: 736-2888
TLX: (790) AA25887

Australia, Ringwood
Elmeasco Instruments Pty. Ltd.
Tel: 879-2322
TLX: (790) AA36206

Austria, Vienna
Walter Rekersch
Elektronische Gerate GmbH & Co.
Tel: 253626
TLX: (847) 134759

Belgium, Brussels
Fluke (Belgium) NV/SA
Tel: 2164090
TLX: (846) 26312

Brazil, Sao Paulo
Hi-Tek Eletronica Ltda.
Tel: 421-5477
TLX: (1391) 1171413

Canada, Calgary
Fluke Electronics Canada Inc.
Tel: (403) 291-5215
Fax: (403) 291-5219

Canada, Mississauga
Fluke Electronics Canada Inc.
Tel: (416) 890-7600
Fax: (416) 890-6866

Canada, Montreal
Fluke Electronics Canada Inc.
Tel: (514) 685-0022
Fax: (514) 685-0039

Canada, Ottawa
Fluke Electronics Canada Inc.
Tel: (613) 723-9453
Fax: (613) 723-9458

Chile, Santiago
Intronica Chile Ltda.
Tel: 232 1886
TLX: (332) 346351

China, Peoples Republic of
Instrimpex - Fluke Service Center
Tel: 65-7281

Colombia, Bogota
Sistemas E Instrumentacion, Ltda.
Tel: 232-4532
TLX: (396) 45787

Denmark, Ballerup
Tage Olson A/S
Tel: 658111
TLX: (855) 35293

Ecuador, Quito
Proteco Coasin Cia., Ltda.
Tel: 526759
TLX: (393) 2865

Egypt and Sudan
Electronic Engineering Liaison Ofc
Tel: 2455705
TLX: (927) 22782

England, Chertsey, Surrey
Amtest Associates, Ltd
Tel: 68355

England, Watford, Herts
Fluke (Great Britain) Ltd
Tel: 40511
TLX: (851) 934583

Finland
Instrumentarium Elektronikka
Tel: 358-0-5281
TLX: (857) 124426

France
M.B. Electronique S.A.
Tel: 1-39-56-81-31
TLX: (842) 695414

Greece, Athens
Hellenic Scientific Representations
Tel: 7211140
TLX: (863) 219330

Hong Kong, Wanchai
Schmidt & Co (H.K.) Ltd.
Tel: 8330-222
TLX: (780) 74766

India, Bangalore
Hinditron Services Pvt. Ltd.
Tel: 363139
TLX: (953) 845741

India, Bombay
Hinditron Services Pvt. Ltd.
Tel: 6300043
TLX: (953) 11-72247

India, New Delhi
Hinditron Services Pvt. Ltd.
Tel: 6433675
TLX: (953) 316458

India, Secunderbad
Hinditron Services Pvt. Ltd.
Tel: 821117
TLX: (953) 1556973

Indonesia, Jakarta Pusat
P.T. Lamda Triguna
Tel: 8195365
TLX: 46171 LAYARIA

Israel, Tel Aviv
R.D.T. Electronics Engineering Ltd.
Tel: 483211
TLX: (922) 371452

Italy, Milan
Sistrel S.p.A.
Tel: 6181893
TLX: (843) 334643

Japan, Tokyo
John Fluke Mfg. Co., Inc.
Japan Branch
Tel: 434-0181
TLX: (781) 242-4331

Korea, Republic of
Myoung Corp.
Tel: 784-9942
TLX: MYOUNG K24283

Malaysia, Selangor
Mecomb Malaysia Sdn. Bhd.
Tel: 3-743422
TLX: (784) MA37764

Mexico
Mexicana de Electronica
Industrial, S.A. (Mexel)
Tel: 5-660-4323
TLX: (383) 1771038

Netherlands, Tilburg
Fluke (Nederland) B.V.
Tel: 352455
TLX: (844) 52683

New Zealand, Auckland
Northrop Instruments
& Systems Ltd.
Tel: 501-801
TLX: (791) NZ21570

New Zealand, Wellington
Northrop Instruments
& Systems Ltd.
Tel: 856-658
TLX: (791) NZ3380

Norway, Oslo
Morgenstjerne & Co. A/S
Tel: 356110
TLX: (856) 71719

Pakistan, Karachi
International Operations (PAK), Ltd.
Tel: 221127, 239052
TLX: (952) 24494

Peru, Lima
Importaciones Y Representaciones
Electronicas S.A.
Tel: 288650
TLX: (394) 25663

Philippines
Spark Radio & Electronics Corp.
Tel: 2-775192
TLX: (722) 27901

Portugal, Lisboa
Equipamentos de Electronica e
Cientificos, SARL.
Tel: 2103420
TLX: (832) 15515

Republic of Singapore
Rank O'Connor's (PTE) Limited
Tel: 4737944
TLX: (826) RS21023

Republic of South Africa, Bramley
Protea PNI
Tel: 11-786-3647
TLX: (960) 4-24409

Spain, Madrid
Equipos y Sistemas S.A.
Tel: 458-0150
TLX: (831) 42856

Sweden, Vallingby
Kaliber AB
Tel: 380350
TLX: (854) 14077

Switzerland, Zurich
Traco Electronic AG
Tel: 2010711
TLX: (845) 815570

Taiwan, Taipei
Schmidt Electronics Corp.
Tel: 5013468
TLX: (785) 11111

Thailand, Bangkok
Measuretronix Ltd.
Tel: 374-2516
TLX: (788) 82796

Turkey, Istanbul
Erkman Elektronik Aletler
Tel: 441546
TLX: (821) 24399

Uruguay, Montevideo
Coasin Uruguay S.A.
Tel: 789015
TLX: (398) UY23010

Venezuela, Caracas
Coasin C.A.
Tel: 241-0309
TLX: (395) 21027

West Germany, Ismaning / Munich
Fluke (Deutschland) GmbH
Tel: 9605240
TLX: (841) 0522472



Appendix 7A

Manual Change Information

INTRODUCTION

This appendix contains information necessary to backdate the manual to conform with earlier pcb configurations. To identify the configuration of the pcb's used in your instrument, refer to the revision letter (marked in ink) on the component side of each pcb assembly. Table 7A-1 defines the assembly revision levels documented in this manual.

NEWER INSTRUMENTS

As changes and improvements are made to the instrument, they are identified by incrementing the revision letter marked on the affected pcb assembly.

These changes are documented on a supplemental change/errata sheet which, when applicable, is inserted at the front of the manual.

OLDER INSTRUMENTS

To backdate this manual to conform with earlier assembly revision levels, perform the changes indicated in Table 7A-1.

CHANGES

There are no backdating changes at this printing. All pcb assemblies are documented at their original revision level.

Table 7A-1. Manual Status and Backdating Information (cont)

Ref Or Option No.	Assembly Name	Fluke Part No.	* To adapt manual to earlier rev configurations perform changes in descending order (by no.), ending with change under desired rev letter															
			-	A	B	C	D	E	F	G	H	J	K	L	M	N	P	
A16	Extended HV PCB Assembly (Fiberglass Case)	514976	X															
A16A1	HV Control PCB Assembly	510032	X															
A17	Power Amp PCB Assembly	458448	●	●	●	●	●	●	●	●	X	X						
A17A1	Power Transistor PCB Assemblyq	438606	●	●	X													
A18	Oscillator PCB Assembly	458455	●	●	●	●	●	X	X									
A19	Isolator PCB Assembly	455832	●	●	●	●	●	●	●	●	X							
A20	Controller PCB Assembly	477083	●	X														
A21	PROM-ROM-RAM PCB Assembly (non-storage)	522821	●	X	X													
A21	PROM-ROM-RAM PCB Assembly (storage)	522854	●	X	X													
A22	Bit Serial Interface Assembly	Opt. -06	●	●	●	●	●	●	●	●	●	●	X					
A23	IEEE-488 Main PCB Assembly	Opt. -05	●	●	●	●	●	●	●	X								
A23A1	IEEE-488 Piggyback PCB Assembly	Opt. -05	X															

* X = The PCB revision levels documented in this manual.
 ● = These revision letters were never used in the instrument.
 -- = No revision letter on the PCB.



Appendix 7B Raymond Tape System Information

The information following this page deals with the Raymond Mini-Raycorder, Model 6409, as adapted to operate with the Fluke Model 5101B Calibrator. Included are details on the Tape Drive and the electronics required to operate it. Operation of the Tape System is covered in Sections 1 and 2 of the Model 5100B Operator's Manual and this Instruction Manual. Electronic theory and maintenance for the Tape Interface Assembly that provides the interface between the Raymond Tape System and the Model 5100B Calibrator is covered in Sections 3, 4, and 5 of this manual.





USER'S MANUAL

MINI-RAYCORDER MODEL 6409

RAYMOND ENGINEERING, INC.

- 217 SMITH STREET -

MIDDLETOWN, CONNECTICUT 06457

Telephone 203-632-1000

Telex 9-9394

TWX 710-428-7944

This document contains information proprietary to Raymond Engineering Inc. Any reproduction, disclosure, or use of this document is expressly prohibited except as Raymond Engineering Inc. may otherwise agree in writing.

COPYRIGHT
RAYMOND ENGINEERING INC.
Middletown, Connecticut
1978

Model 6409-11B (Fluke) Manual Addendum

The Fluke version of the Mini-Raycorder is designated as Model 6409-11B. It is similar to the standard 6409-11 unidirectional unit. All reference to the 6409-21 bidirectional unit is not applicable. Specific exceptions are as follows:

1. Table 1 Mini-Raycorder specifications are defined in the Fluke component specification JF P/N 429688. Taking into account temperature, humidity and voltage ranges, the specs become:

Start time: 300msec max., 50 msec min.
Stop time: 120msec max., 20 msec min.
Power Req: +5. \pm .25VDC @ 100ma
Motor + 5VDC is +5 \pm .25VDC @ 270 ma run
and 570ma surge
Error Rate: 1 bit error in 10^6 bits transferred

2. Figures 3, 10, 11, 12, 13, 14 and 15 are not applicable.
3. Page 6 Interface Data . . . An AMP connector type 2-87456-2 or equivalent is required to mate with the electronics assembly.
4. Table 2 - the pin numbering is different

<u>Pin Number</u>	<u>Signal Name</u>
13	MOTOR +5VDC
12	+5VDC
11	MOTOR GND
10	SIGNAL GND
5	DATA IN
4	<u>READ/WRITE</u>
2	<u>TAPE POSITION</u>
1	<u>FWD/RWND</u>
26	<u>CASSETTE LOADED</u>
25	SIDE A/ <u>B</u>
24	CHASSIS GND
21	KEYING POSITION
19	<u>DATA OUT</u>
18	<u>WRITE INHIBIT</u>
17	MOTION



TABLE OF CONTENTS

	Page
GENERAL DESCRIPTION	
INTRODUCTION	1
DESCRIPTION	1
MINI-RAYRECORDER	1
TAPE TRANSPORT	3
ELECTRONICS	3
PREPARATION FOR USE	
INTRODUCTION	5
UNPACKING	5
RECEIVING INSPECTION	5
PACKAGING	5
INTERFACE/INSTALLATION DATA	
INTRODUCTION	6
INTERFACE DATA	6
INSTALLATION DATA	6
TAPE TRANSPORT	6
ELECTRONICS ASSEMBLY	6
TAPE TRANSPORT DESCRIPTION	
INTRODUCTION	11
MINI-CASSETTE INSERTION AND REMOVAL	11
INSERTION INSTRUCTIONS	11
REMOVAL INSTRUCTIONS	11
ANSI COMPATIBILITY/INTERCHANGEABILITY	11
TAPE TRANSPORT COMPONENT FUNCTION	11
FUNCTIONAL DESCRIPTION	
INTRODUCTION	14
TAPE TRANSPORT	14
INTERLOCK SWITCHES	14
BOT/EOT DETECTION CIRCUITS	14
DC SERVO MOTORS	14
RECORDING HEAD	14
ELECTRONICS ASSEMBLY	14
SERVO CONTROL ELECTRONICS	14
Forward Tach Signal Conditioning Network	16
Error Correction And Motor Compensation	16
Reverse Tach Signal Conditioning Network	16
Comparator	16
Ramped Speed Reference Input	16
Forward Motor Power Amplifier	16
Reverse Motor Power Amplifier	16
Tape Tensioning	16
READ/WRITE CIRCUITS	16
Write Drivers	19
Write Power Control	19
Read Signal Conditioning	19
Data Peak Detector	19
Threshold Detectors	19
Data Latch	19
INTERFACE TIMING	19

MINI-RAYCORDER

TABLE OF CONTENTS (Cont)

	Page
MAINTENANCE	
INTRODUCTION	27
SPECIAL TOOLS AND TEST EQUIPMENT	27
PREVENTIVE MAINTENANCE	27
REPAIR	27
ALIGNMENT AND CALIBRATION	27
TEST	29
TROUBLESHOOTING	29
SCHEMATIC DIAGRAMS	29

LIST OF ILLUSTRATIONS

Figure	Title	Page
1	Series 6409 Mini-Raycorder	1
2	Mini-Raycorder Functional Diagram	2
3	Installation of Tape Transport	9
4	Mini-Cassette Insertion & Removal	11
5	Tape Transport Component Location	13
6	BOT/EOT Detection Circuit Block Diagram	15
7	Magnetic Tape Track Configuration	15
8	Servo Control Electronics Block Diagram With Accompanying Waveforms	17
9	Read/Write Electronics Block Diagram With Accompanying Waveforms	21
10	Writing Blocks With Stops In Between	23
11	Writing First Block	24
12	Writing Blocks Without Stops	25
13	Writing Last Data Block (Writing Data When Early Warning Occurs)	25
14	Data Block Definition Timing Diagram	26
15	Reading With and Without Stops	26
16	Head Penetration Alignment	28
17	Tape Path Alignment	28
18	Mini-Raycorder Uni-Directional Model 6409-11B Schematic Diagram	33

LIST OF TABLES

Table	Title	Page
1	Series 6409 Mini-Raycorder Specifications	4
2	Pin Assignments at I/O Header Interface Connector	7
3	Tape Transport Component Description	12
4	Mini-Raycorder Test Procedure	30
5	Mini-Raycorder Troubleshooting	31